

YASKAWA AC Drive 1000-Series Option

# Motor Feedback Resolver TS2640N321E64 Interface Installation Manual

Type: PG-RT3

To properly use the product, read this manual thoroughly and retain for easy reference, inspection, and maintenance. Ensure the end user receives this manual.

---

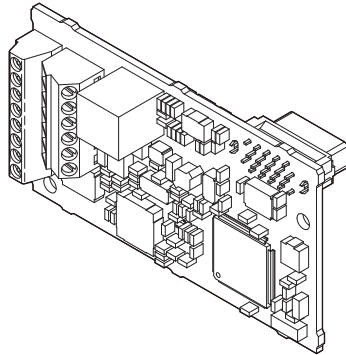

---

## **Copyright © 2010 YASKAWA ELECTRIC CORPORATION**

All rights reserved. No part of this publication may be reproduced, stored in a retrieval system, or transmitted, in any form or by any means, mechanical, electronic, photocopying, recording, or otherwise, without the prior written permission of Yaskawa. No patent liability is assumed with respect to the use of the information contained herein. Moreover, because Yaskawa is constantly striving to improve its high-quality products, the information contained in this manual is subject to change without notice. Every precaution has been taken in the preparation of this manual. Yaskawa assumes no responsibility for errors or omissions. Neither is any liability assumed for damages resulting from the use of the information contained in this publication.

# Table of Contents

---

<b>1 Preface and Safety</b> .....	<b>4</b>
<b>2 Product Overview</b> .....	<b>8</b>
<b>3 Receiving</b> .....	<b>9</b>
<b>4 Option Components</b> .....	<b>10</b>
<b>5 Installation Procedure</b> .....	<b>11</b>
<b>6 Related Parameters</b> .....	<b>24</b>
<b>7 Troubleshooting</b> .....	<b>26</b>
<b>8 Specifications</b> .....	<b>30</b>

## 1 Preface and Safety

Yaskawa manufactures products used as components in a wide variety of industrial systems and equipment. The selection and application of Yaskawa products remain the responsibility of the equipment manufacturer or end user. Yaskawa accepts no responsibility for the way its products are incorporated into the final system design. Under no circumstances should any Yaskawa product be incorporated into any product or design as the exclusive or sole safety control. Without exception, all controls should be designed to detect faults dynamically and fail safely under all circumstances. All systems or equipment designed to incorporate a product manufactured by Yaskawa must be supplied to the end user with appropriate warnings and instructions as to the safe use and operation of that part. Any warnings provided by Yaskawa must be promptly provided to the end user. Yaskawa offers an express warranty only as to the quality of its products in conforming to standards and specifications published in the Yaskawa manual. **NO OTHER WARRANTY, EXPRESS OR IMPLIED, IS OFFERED.** Yaskawa assumes no liability for any personal injury, property damage, losses, or claims arising from misapplication of its products.

### ◆ Applicable Documentation

The following manuals are available for the option:

#### Option

	<p><b>Yaskawa AC Drive 1000-Series Option Motor Feedback Resolver TS2640N321E64 Interface PG-RT3 Installation Manual (This book) Manual No: TOBPC73060053</b></p>	<p>Read this manual first. The installation manual is packaged with the option and contains information required to install the option and set up related drive parameters.</p>
--	---	---

#### Yaskawa Drive

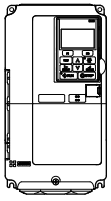
	<p><b>Yaskawa AC Drive 1000-Series Quick Start Guide</b></p> <p><b>Yaskawa AC Drive 1000-Series Technical Manual</b></p>	<p>The drive manuals cover basic installation, wiring, operation procedures, functions, troubleshooting, and maintenance information.</p> <p>The manuals also include important information about parameter settings and drive tuning.</p> <p>Access these sites to obtain Yaskawa instruction manuals:          U.S.: <a href="http://www.yaskawa.com">http://www.yaskawa.com</a>          Europe: <a href="http://www.yaskawa.eu.com">http://www.yaskawa.eu.com</a>          Japan: <a href="http://www.e-mechatronics.com">http://www.e-mechatronics.com</a></p> <p>For questions, contact your local Yaskawa sales office or the nearest Yaskawa representative.</p>
--	---	--

## ◆ Terms and Abbreviations

<b>Note:</b>	Indicates supplemental information that is not related to safety messages
<b>Drive:</b>	Yaskawa AC Drive 1000-Series
<b>Option:</b>	Yaskawa AC Drive 1000-Series Option Motor Feedback Resolver TS2640N321E64 Interface: Type PG-RT3
<b>PG:</b>	Pulse Generator, Encoder, or Resolver mounted on the motor
<b>V/f:</b>	V/f Control
<b>V/f w/PG:</b>	V/f Control with PG
<b>CLV:</b>	Closed Loop Vector Control
<b>AOLV/PM:</b>	Advanced Open Loop Vector Control for PM
<b>CLV/PM:</b>	Closed Loop Vector Control for PM

---

## ◆ Registered Trademarks

Trademarks are the property of their respective owners.

# 1 Preface and Safety

---

## ◆ Supplemental Safety Information

Read and understand this manual before installing, operating, or servicing this option. Install the option according to this manual and local codes.

The following conventions indicate safety messages in this manual. Failure to heed these messages could cause fatal injury or damage products and related equipment and systems.

### **DANGER**

Indicates a hazardous situation, which, if not avoided, will result in death or serious injury.

### **WARNING**

Indicates a hazardous situation, which, if not avoided, could result in death or serious injury.

### **CAUTION**

Indicates a hazardous situation, which, if not avoided, could result in minor or moderate injury.

### **NOTICE**

Indicates an equipment damage message.

## ■ General Safety

### General Precautions

- The diagrams in this book may include options and drives without covers or safety shields to illustrate details. Be sure to reinstall covers or shields before operating any devices. Use the option according to the instructions described in this manual.
- Any illustrations, photographs, or examples used in this manual are provided as examples only and may not apply to all products to which this manual is applicable.
- The products and specifications described in this manual or the content and presentation of the manual may be changed without notice to improve the product and/or the manual.
- When ordering new copies of the manual, contact a Yaskawa representative or the nearest Yaskawa sales office and provide the manual number shown on the front cover.

### DANGER

#### **Heed the safety messages in this manual.**

Failure to comply will result in death or serious injury.

The operating company is responsible for any injuries or equipment damage resulting from failure to heed the warnings in this manual.

### NOTICE

#### **Do not modify the drive or option circuitry.**

Failure to comply could result in damage to the drive or option and will void warranty. Yaskawa is not responsible for any modification of the product made by the user. This product must not be modified.

#### **Do not expose the drive or option to halogen group disinfectants.**

Failure to comply may cause damage to the electrical components in the option.

Do not pack the drive in wooden materials that have been fumigated or sterilized.

Do not sterilize the entire package after the product is packed.

# 2 Product Overview

### ◆ About This Product

The PG-RT3 Option enables the user to connect to a resolver that meets Yaskawa's specifications such as the TS2640N321E64 made by Tamagawa Seiki Co., Ltd.

The PG-RT3 Option facilitates motor speed feedback to the drive and takes advantage of Closed Loop Vector control for PM Motors. The option increases control accuracy and performance.

A resolver signal allows the drive to compensate for subtle variations in the load, while providing the drive with the necessary data to control the output frequency and maintain an accurate constant speed.

The PG-RT3 Option requires a resolver with an input voltage of 7 Vac rms 10 kHz, transformation ratio of 0.5 ±5%, and a maximum input current of 100 mA rms.

When using the PG-RT3 Option, the drive must be in the Closed Loop Vector Control for PM Motors control mode. Refer to the Technical Manual of the drive for details.

### ◆ Applicable Models

The option can be used with the drive models in [Table 1](#).

**Table 1 Applicable Models**

Drive Series	Drive Model Number
A1000	All models <I>

<I> Only available in software version S1017 and later. The software version (PRG) is indicated on the nameplate affixed to the side of the drive.





## 3 Receiving

Please perform the following tasks upon receiving the option:

- Inspect the option for damage. Contact the shipper immediately if the option appears damaged upon receipt.
- Verify receipt of the correct model by checking the model number printed on the option nameplate (Refer to *Figure 1* on page 10 for more information).
- Contact your supplier if you have received the wrong model or the option does not function properly.

### ◆ Option Package Contents

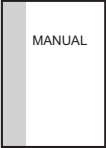
Description:	Option	Ground Wire	Screws (M3)	Installation Manual
				
Quantity:	1	1	3	1

### ◆ Tools Required for Installation

- A Phillips screwdriver (M3 metric / #1, #2 U.S. standard size) is required to install the option.
- A straight-edge screwdriver (blade depth: 0.4 mm, width: 2.5 mm) is required to wire the option terminal block.
- A pair of diagonal cutting pliers.
- A small file or medium-grit sandpaper.

**Note:** Tools required to prepare option cables for wiring are not listed in this manual.

# 4 Option Components

### ◆ PG-RT3 Option

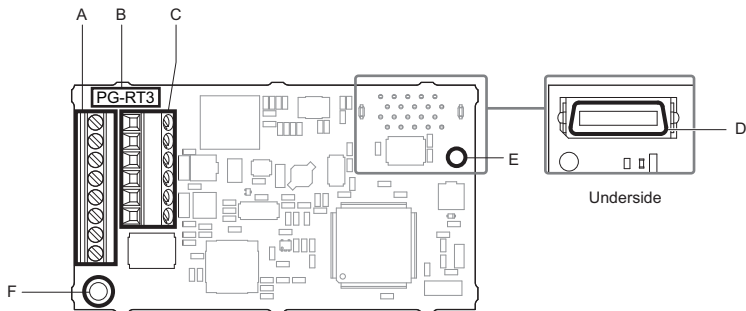

**A** – Terminal block TB1

**B** – Model number

**C** – Terminal block TB2

**D** – Connector (CN5)

**E** – Installation hole

**F** – Ground terminal and installation hole <1>

<1> The ground wires provided in the option shipping package must be connected during installation.

**Figure 1 PG-RT3 Option Components**

### ◆ Terminal Blocks TB1 and TB2

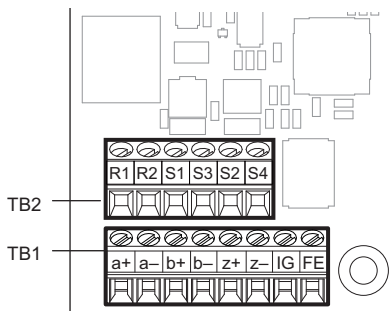

Refer to [Table 4](#) on page [23](#) for details on TB1 and TB2 terminal functions and signal levels.

## 5 Installation Procedure

### ◆ Section Safety

#### DANGER

##### **Electric Shock Hazard**

**Do not connect or disconnect wiring while the power is on.**

Failure to comply will result in death or serious injury.

Disconnect all power to the drive, wait at least the amount of time specified on the drive front cover safety label. After all indicators are off, measure the DC bus voltage to confirm safe level, and check for unsafe voltages before servicing. The internal capacitor remains charged after the power supply is turned off.

#### WARNING

##### **Electrical Shock Hazard**

**Do not remove the front covers of the drive while the power is on.**

Failure to comply could result in death or serious injury.

The diagrams in this section may include options and drives without covers or safety shields to show details. Be sure to reinstall covers or shields before operating any devices. Use the option according to the instructions described in this manual.

**Do not allow unqualified personnel to use equipment.**

Failure to comply could result in death or serious injury.

Maintenance, inspection, and replacement of parts must be performed only by authorized personnel familiar with installation, adjustment, and maintenance of this product.

**Do not touch circuit boards while the power to the drive is on.**

Failure to comply could result in death or serious injury.

## 5 Installation Procedure

### **WARNING**

**Do not use damaged wires, stress the wiring, or damage the wire insulation.**

Failure to comply could result in death or serious injury.

#### **Fire Hazard**

**Tighten all terminal screws to the specified tightening torque.**

Loose electrical connections could result in death or serious injury by fire due to overheating of electrical connections.

### **NOTICE**

#### **Damage to Equipment**

**Observe proper electrostatic discharge (ESD) procedures when handling the option, drive, and circuit boards.**

Failure to comply may result in ESD damage to circuitry.

**Never shut the power off while the drive is running or outputting voltage.**

Failure to comply may cause the application to operate incorrectly or damage the drive.

**Do not operate damaged equipment.**

Failure to comply may cause further damage to the equipment.

Do not connect or operate any equipment with visible damage or missing parts.

**Tighten all terminal screws to the specified tightening torque.**

Failure to comply could result in damage to the terminal block.

**Do not use unshielded cable for control wiring.**

Failure to comply may cause electrical interference resulting in poor system performance.

Use shielded twisted-pair wires and ground the shield to the ground terminal of the drive.

### NOTICE

**Properly connect all pins and connectors.**

Failure to comply may prevent proper operation and possibly damage equipment.

**Check wiring to ensure that all connections are correct after installing the option and connecting any other devices.**

Failure to comply may result in damage to the option.

## 5 Installation Procedure

### ◆ Prior to Installing the Option

Prior to installing the option, wire the drive, make the necessary connections to the drive terminals, and verify that the drive functions normally. Refer to the Quick Start Guide packaged with the drive for information on wiring and connecting the drive.

*Figure 2* shows an exploded view of the drive with the option and related components for reference.

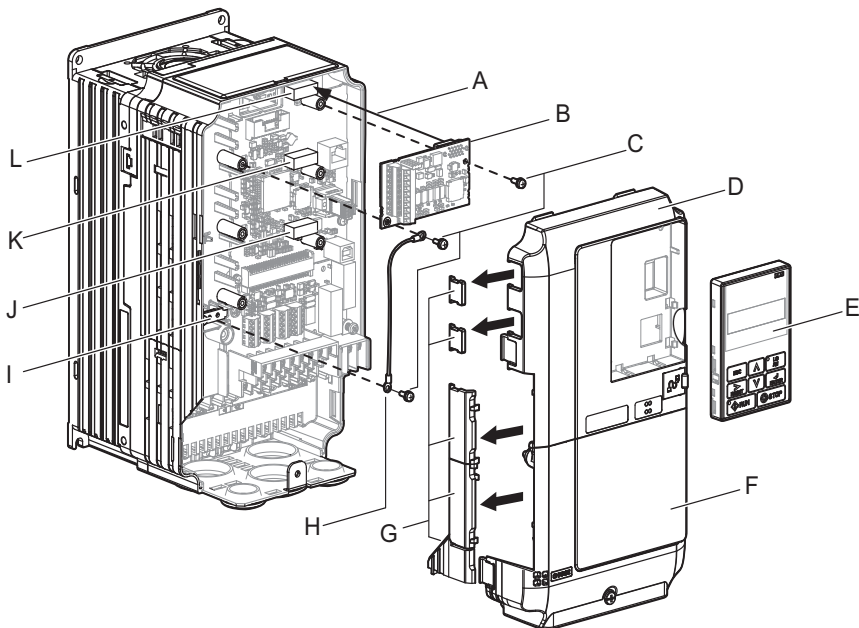

A – Insertion point for CN5

B – Option card

C – Included screws

D – Front cover

E – Digital operator

F – Terminal cover

G – Removable tabs for wire routing

H – Ground wire

I – Drive grounding terminal (FE)

J – Connector CN5-A

K – Connector CN5-B

L – Connector CN5-C

Figure 2 Drive Components with Option

### ◆ Installing the Option

Refer to the instructions below to install the option.

1. Shut off power to the drive, wait the appropriate amount of time for voltage to dissipate, then remove the digital operator (E), front cover (D), and terminal cover (F). Refer to the Quick Start Guide packaged with the drive.

**DANGER!** *Electrical Shock Hazard. Disconnect all power to the drive and wait at least the amount of time specified on the drive front cover safety label. After all indicators are off, measure the DC bus voltage to confirm safe level, and check for unsafe voltages before servicing to prevent electric shock. The internal capacitor remains charged even after the power supply is turned off.*

**NOTICE:** *Damage to Equipment. Observe proper electrostatic discharge procedures (ESD) when handling the option, drive, and circuit boards. Failure to comply may result in ESD damage to circuitry.*

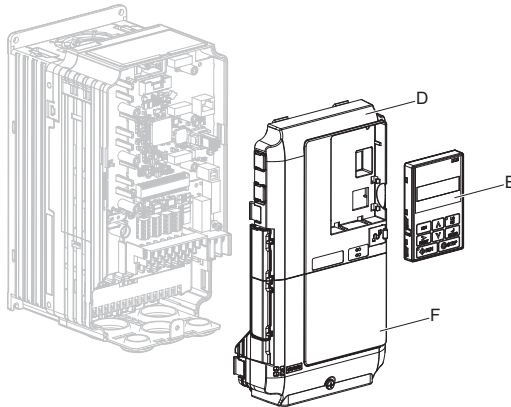

Figure 3 Remove the Front Cover, Terminal Cover, and Digital Operator

## 5 Installation Procedure

---

2. Insert the option card (B) into the CN5-C (L) connector located on the drive and fasten it into place using one of the included screws (C).

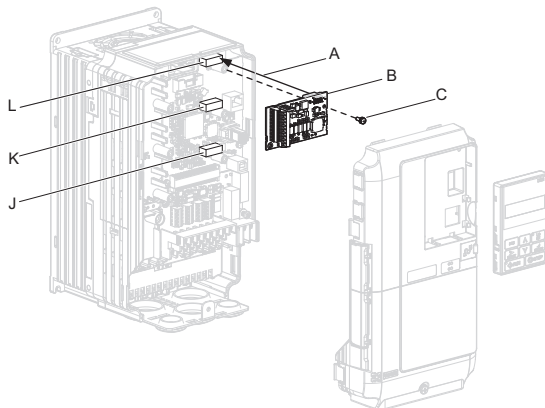
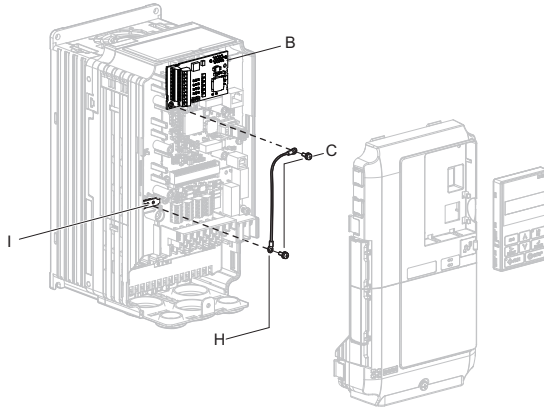

Figure 4 Insert the Option Card



3. Connect the ground wire (H) to the ground terminal (I) using one of the remaining screws (C). Connect the other end of the ground wire (H) to the remaining ground terminal and installation hole on the option (B) using the last remaining provided screw (C).



**Figure 5 Connect the Ground Wire**

**Note:** There are two screw holes on the drive for use as ground terminals (I). When connecting three options, two ground wires will need to share the same drive ground terminal.

## 5 Installation Procedure

4. Prepare and connect the wire ends as shown in [Figure 6](#) and [Figure 7](#). Refer to [Wire Gauges and Tightening Torques on page 22](#) to confirm that the proper tightening torque is applied to each terminal. Take particular precaution to ensure that each wire is properly connected and wire insulation is not accidentally pinched into electrical terminals.

**WARNING! Fire Hazard.** Tighten all terminal screws according to the specified tightening torque. Loose electrical connections could result in death or serious injury by fire due to overheating electrical connections. Tightening screws beyond the specified tightening torque may result in erroneous operation, damage the terminal block, or cause a fire.

**NOTICE:** Heat shrink tubing or electrical tape may be required to ensure that cable shielding does not contact other wiring. Insufficient insulation may cause a short circuit and damage the option or drive.

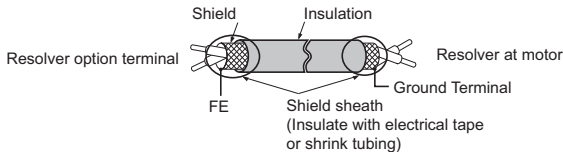

Figure 6 Preparing Ends of Shielded Cable

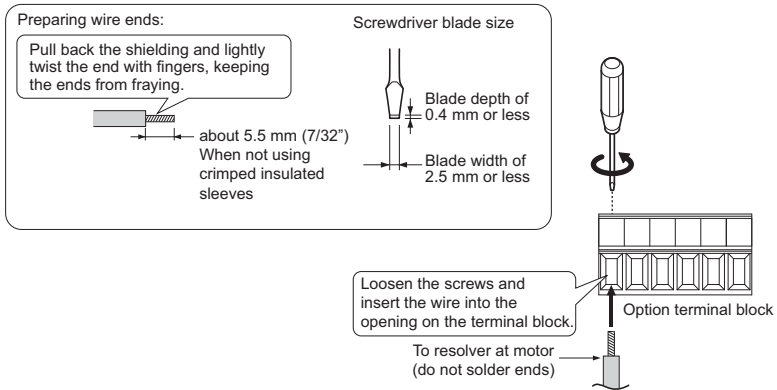
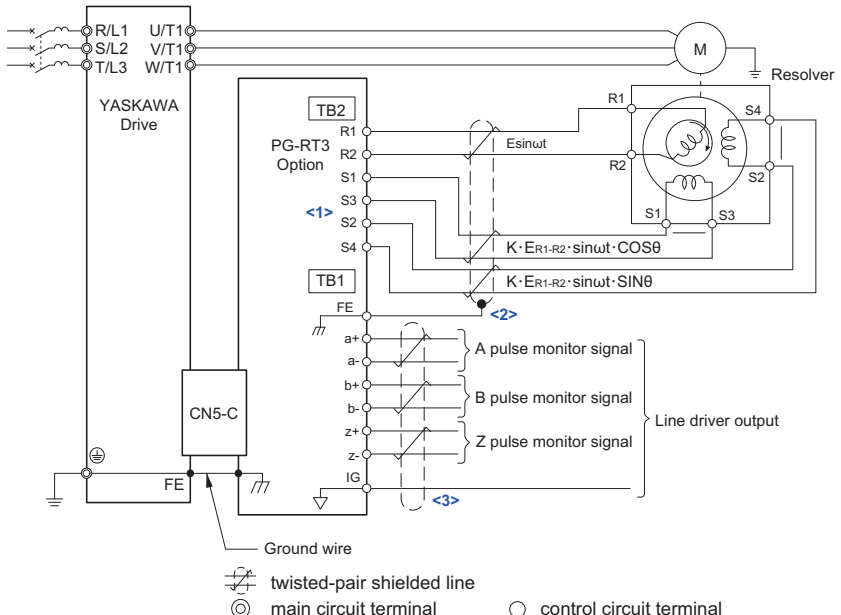

Figure 7 Preparing and Connecting Cable Wiring

5. Wire the motor resolver to the terminal block on the option. Refer to [Figure 6](#) and [Figure 7](#) for wiring instructions. Refer to [Figure 8](#) for the connection diagram. Limit the length of all motor output power cables to less than 10 m. [Refer to Option Terminal Functions on page 23](#) for a detailed description of the option terminal functions.



- <1> Connect resolver terminals S1 through S4 to PG-RT3 option terminals S1 through S4. Be sure not to mistakenly connect the resolver to drive terminals S1 through S4.
- <2> Ground the shield on the resolver side and the drive side. If noise problems arise in the resolver signal, remove the shield ground from one end of the signal line or remove the shield ground connection on both ends.
- <3> Yaskawa recommends using shielded twisted-pair cables.

**Figure 8 PG-RT3 Option and Resolver Connection Diagram**

## 5 Installation Procedure

- 6.** Route the option wiring.  
Depending on the drive model, some drives may require routing the wiring through the side of the front cover to the outside. In these cases, cut out the perforated openings on the left side of the drive front cover as shown in **Figure 9-A** and leave no sharp edges to damage wiring.  
Route the wiring inside the enclosure as shown in **Figure 9-B** for drives that do not require routing through the front cover.  
Refer to the *Peripheral Devices & Options* section of the drive Technical Manual for more information.

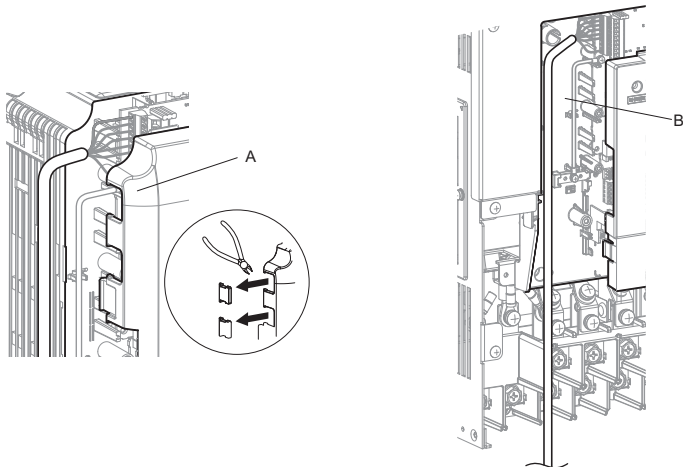

**A** – Route wires through the openings provided on the left side of the front cover. <1>

**B** – Use the open space provided inside the drive to route option wiring.

<1> The drive will not meet NEMA Type 1 requirements if wiring is exposed outside the enclosure.

**Figure 9 Wire Routing Examples**

7. Replace and secure the front covers of the drive (D, F) and replace the digital operator (E).

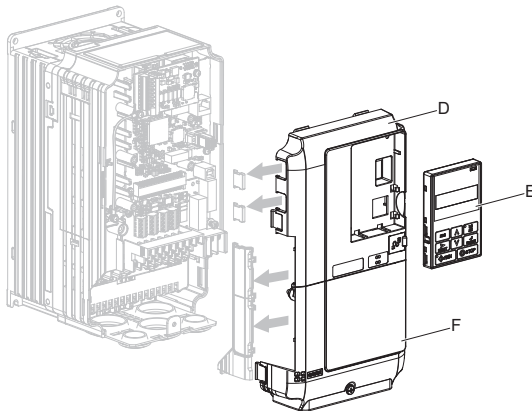
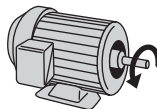

**Figure 10 Replace the Front Covers and Digital Operator**

**Note:** Take proper precautions when wiring the option so that the front covers will easily fit back onto the drive. Make sure cables are not pinched between the front covers and the drive when replacing the covers.

8. After connecting the resolver outputs to the option, apply power to the drive and manually rotate the motor and check the rotation direction by viewing monitor U1-05 on the digital operator.  
The value in U6-18 increases during forward rotation (value will reset to 0 after exceeding 65535), and decreases during reverse rotation (counts back from 65535 after reaching 0).  
If the value in U6-18 decreases while the motor is rotating forwards as shown in [Figure 11](#), switch the PG rotation setting (F1-05 = 1) to change how the drive reads the direction of the motor PG encoder.

**Note:** If the drive is initialized using A1-03 = 1110, 2220, or 3330, the value for F1-05 will reset to factory default and the parameter will need to be adjusted again to switch the direction.



**Figure 11 Forward direction**

## 5 Installation Procedure

### ◆ Wire Gauges, Tightening Torque, and Crimp Terminals

#### ■ Wire Gauges and Tightening Torques

Wire gauge and torque specifications are listed in [Table 2](#).

**Table 2 Wire Gauges and Tightening Torques**

Terminal Signal	Screw Size	Tightening Torque N·m (in·lb)	Bare Cable		Crimp Terminals		Wire Type
			Applicable Gauges mm <sup>2</sup>	Recomm. Gauge mm <sup>2</sup>	Applicable Gauges mm <sup>2</sup>	Recomm. Gauge mm <sup>2</sup>	
R1, R2, S1, S2, S3, S4	M2	0.22 to 0.25 (1.95 to 2.21)	Stranded wire: 0.25 to 1.0 (24 to 17 AWG)	0.75 (18 AWG)	0.25 to 0.5 (24 to 20 AWG)	0.5 (20 AWG)	Shielded twisted pair, etc.
a+, a-, b+, b-, z+, z-, IG, FE			Solid wire: 0.25 to 1.5 (24 to 16 AWG)				Shielded cable, etc.

#### ■ Crimp Terminals

Yaskawa recommends using CRIMPFOX 6 by Phoenix Contact or equivalent crimp terminals with the specifications listed in [Table 3](#) for wiring to ensure proper connections.

**Note:** Properly trim wire ends so loose wire ends do not extend from the crimp terminals.

**Table 3 Crimp Terminal Sizes**

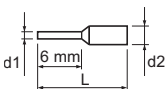
	Wire Gauge mm <sup>2</sup>	Phoenix Contact Model	L mm (in)	d1 mm (in)	d2 mm (in)
	0.25 (24 AWG)	AI 0.25 - 6YE	10.5 (13/32)	0.8 (1/32)	2 (5/64)
	0.34 (22 AWG)	AI 0.34 - 6TQ	10.5 (13/32)	0.8 (1/32)	2 (5/64)
	0.5 (20 AWG)	AI 0.5 - 6WH	14 (9/16)	1.1 (3/64)	2.5 (3/32)

### ◆ Terminal Functions

**Table 4 Option Terminal Functions**

Terminal Block	Terminal	Function	Description
TB1	a+	A pulse monitor signal	Outputs a resolver monitor signal for the A, B, and Z channels. <ul style="list-style-type: none"> <li>• Signal voltage: RS-422 level</li> <li>• Pulses: 1024 ppr &lt;/&gt;</li> </ul>
	a-	A pulse inverse monitor signal	
	b+	B pulse monitor signal	
	b-	B pulse inverse monitor signal	
	z+	Z pulse monitor signal	
	z-	Z pulse inverse monitor signal	
	IG	Monitor ground	0 V
	FE	Ground	Ground terminal for shielded cable.
TB2	R1	Resolver signal	Excitation signal relative to the resolver <ul style="list-style-type: none"> <li>• Output voltage: 7 Vrms</li> <li>• Output frequency: 10 kHz</li> </ul>
	R2		
	S1 </>	Signal from resolver (COS)	Sine wave from resolver Transformation Ratio: 0.5 ±5%
	S3 </>	Signal from resolver (SIN)	
	S2 </>		
S4 </>			

<1> Irregular monitor pulses can occur with faulty wiring or a defective resolver.

<2> Connect resolver terminals S1 through S4 to PG-RT3 terminals S1 through S4. Be sure not to connect the resolver to drive terminals S1 through S4.

# 6 Related Parameters

The following parameters set the drive for operation with the option. Set parameters as needed. Parameter setting methods can be found in the drive Quick Start Guide or Technical Manual.

**Table 5 Related Parameters**

No. (Addr. Hex)	Name	Description	Control Mode	Values
A1-02 (102)	Control Method Selection	0: V/f Control 1: V/f Control with PG 2: Open Loop Vector Control 3: Closed Loop Vector Control 5: Open Loop Vector Control for PM 6: Advanced Open Loop Vector Control for PM 7: Closed Loop Vector Control for PM <b>Note:</b> Set to 7 when using PG-RT3.	All Modes	Default: </> Range: </>
F1-02 (381)	PG Feedback Loss Operation Selection	Sets the stopping method after PG disconnect (PGo). 0: Ramp to stop (decelerates at time set to C1-02) 1: Coast to stop 2: Fast Stop (decelerates at the time set to C1-09) 3: Continue running 4: No alarm display <b>NOTICE:</b> Due to potential damage to the motor and machinery, only use settings 3 and 4 under special circumstances.	CLV CLV/PM	Default: 1 Range: </>
F1-03 (382)	PG Overspeed Operation Selection	Sets the stopping method after detecting overspeed. 0: Ramp to stop (decelerates at time set to C1-02) 1: Coast to stop 2: Fast Stop (decelerates at the time set to C1-09) 3: Continue running <b>NOTICE:</b> Due to potential damage to the motor and machinery, do not use the "Continue running" setting except under special circumstances.	CLV CLV/PM	Default: 1 Range: 0 to 3
F1-04 (383)	PG Deviation Operation Selection	0: Ramp to stop (decelerates at time set to C1-02) 1: Coast to stop 2: Fast Stop (decelerates at the time set to C1-09) 3: Continue running <b>NOTICE:</b> Due to potential damage to the motor and machinery, do not use the "Continue running" setting except under special circumstances.	CLV CLV/PM	Default: </> Range: 0 to 3
F1-05 (384)	PG 1 Rotation	0: Forward = A pulse leads 1: Forward = B pulse leads	CLV CLV/PM	Default: </> Range: 0, 1
F1-08 (387)	PG Overspeed Level	Sets the level for detecting overspeed as a percentage of the maximum output frequency.	CLV CLV/PM	Default: 115 Min: 0 Max: 120



## 6 Related Parameters

No. (Addr. Hex)	Name	Description	Control Mode	Values
F1-09 (388)	Overspeed Det. Time	Sets the time required for the motor to exceed the level set in F1-08 to trigger a fault.	CLV CLV/PM	Default: 0.0 Min: 0.0 Max: <1>
F1-10 (389)	Excessive Speed Deviation Det. Level	Sets the degree of speed deviation to trigger a dEv fault. Set as a percentage of the maximum output frequency.	CLV CLV/PM	Default: 10 Min: 0 Max: 50
F1-11 (38A)	Excessive Speed Deviation Det. Time	Sets the time required for a speed deviation situation to trigger a fault.	CLV CLV/PM	Default: 0.5 Min: 0.0 Max: 10.0
F1-14 (38D)	PG Disconnect Det. Time	Sets the time in seconds for PG encoder disconnect to be detected.	CLV CLV/PM	Default: 2.0 Min: 0.0 Max: 10.0
F1-18 (3AD)	Reverse Rotation Det. for PG 1	0: Disabled n: Number of times a dv3 situation must be detected to trigger a fault.	CLV/PM	Default: 10 Min: 0 Max: 10
F1-19 (3AE)	Reverse Rotation Det. for PG 1	0: Disabled n: Number of times a dv4 situation must be detected to trigger a fault.	CLV/PM	Default: 128 Min: 0 Max: 5000

<1> Varies by drive model.

<2> Value changes according to the control mode selection in A1-02.

# 7 Troubleshooting

### ◆ Drive-Side Error Codes

**Table 6** lists the various fault codes related to the option and pulse generator. Refer to the drive Technical Manual for further details on fault codes.





Check the following items first when an error code occurs on the drive:

- Are the cables connected properly and securely?
- Is the option properly installed to the drive?
- Did a momentary power loss occur?

**Table 6 Fault Displays, Causes, and Possible Solutions**

Digital Operator Display		Fault Name
dEv	dEv	Speed Deviation (for Control Mode with PG)
		The deviation between the speed reference and speed feedback is greater than the setting in F1-10 for longer than the time set to F1-11.
<b>Cause</b>		<b>Possible Solution</b>
The load is too heavy.		Reduce the load.
The acceleration and deceleration times are set too short.		Increase the acceleration and deceleration times (C1-01 through C1-08).
The load is locked up.		Check the machine.
Parameters are set inappropriately.		Check the settings of parameters F1-10 and F1-11.
Motor brake is engaged.		Ensure the motor brake releases properly.
Digital Operator Display		Fault Name
dv3	dv3	Inversion Detection
		<ul style="list-style-type: none"> <li>• Torque reference and acceleration are in opposite directions.</li> <li>• The speed reference and actual motor speed differ by over 30% for the number of pulses set to parameter F1-18.</li> </ul>
<b>Cause</b>		<b>Possible Solution</b>
An external force on the load side caused the motor to move.		<ul style="list-style-type: none"> <li>• Make sure the motor is rotating in the proper direction.</li> <li>• Investigate problems on the load side causing motor rotation in the opposite direction.</li> </ul>
Noise interference along the resolver cable.		<ul style="list-style-type: none"> <li>• Check resolver wiring and make sure all wiring including shielded wiring is properly connected.</li> <li>• If the problem continues after cycling power, replace the PG option or the resolver.</li> </ul>
The resolver is disconnected or is not wired properly, or the resolver option or resolver are damaged.		

## 7 Troubleshooting

The resolver rotational direction set to F1-05 is in the opposite direction of the motor wiring.		Make sure motor wiring for each phase (U, V, W) is connected properly.
Digital Operator Display		Fault Name
	dv4	Inversion Prevention Detection
		Pulses indicate that the motor is rotating in the opposite direction of the speed reference. Set the number of pulses to trigger inverse detection to F1-19. <b>Note:</b> To avoid nuisance faults, be sure to disable inverse detection in applications where the motor may rotate in the opposite direction of the speed reference. Set F1-19 to 0 to disable this feature.
Cause		Possible Solution
Noise interference along the resolver cable.		<ul style="list-style-type: none"> <li>Make sure the motor is rotating in the proper direction.</li> <li>Investigate problems on the load-side that may be causing the motor to rotate in the opposite direction.</li> </ul>
Resolver is disconnected or is not wired properly, or the PG option or resolver are damaged.		<ul style="list-style-type: none"> <li>Check resolver wiring and make sure all wiring including shielded wiring is properly connected.</li> <li>If the problem continues after cycling power, replace the PG option or the resolver.</li> </ul>
Digital Operator Display		Fault Name
	oFA00	Non-compatible option is connected to drive port CN5-A.
Cause		Possible Solution
Non-compatible option is connected to drive port CN5-A.		Use only compatible options. Connect PG-RT3 to CN5-C. For other options, refer to the Installation Manual for that option.
Digital Operator Display		Fault Name
	oFb00	Non-compatible option is connected to drive port CN5-B.
Cause		Possible Solution
Non-compatible option is connected to drive port CN5-B.		Use only compatible options. Connect PG-RT3 to CN5-C. For other options, refer to the Installation Manual for that option.
Digital Operator Display		Fault Name
	oFC01	Option Connection Error at drive port CN5-C
Cause		Possible Solution
Option at drive port CN5-C was changed during run.		Switch the power off and reconnect the option.
Digital Operator Display		Fault Name
	oFC50	PG Encoder Option A/D Conversion Error
		Error with the A/D conversion level (VCC level), or A/D conversion timed out.
Cause		Possible Solution
The option is damaged.		Replace the option.

## 7 Troubleshooting

Digital Operator Display		Fault Name
oFC51	oFC51	PG Encoder Option Analog Circuit Error
		Internal power supply voltage level error
<b>Cause</b>		<b>Possible Solution</b>
The option is damaged.		Replace the option.
Digital Operator Display		Fault Name
oFC52	oFC52	PG Encoder Communication Timeout
		Serial encoder timed out waiting to receive data
<b>Cause</b>		<b>Possible Solution</b>
Resolver wiring is incorrect.		Correct the wiring.
Resolver cable is disconnected.		Reconnect the cable.
Digital Operator Display		Fault Name
oFC53	oFC53	PG Encoder Communication Data Error
		Serial encoder CRC checksum error
<b>Cause</b>		<b>Possible Solution</b>
Resolver wiring is incorrect.		Correct the wiring.
Resolver cable is disconnected.		Reconnect the cable.
Digital Operator Display		Fault Name
oFC55	oFC55	Resolver Error
		Resolver disconnected or damaged
<b>Cause</b>		<b>Possible Solution</b>
Resolver wiring is incorrect.		Correct the wiring.
Resolver cable is disconnected.		Reconnect the cable.
The option is damaged.		Replace the option.
Digital Operator Display		Fault Name
oS	oS	Overspeed
		The motor speed feedback exceeded the F1-08 setting.
<b>Cause</b>		<b>Possible Solution</b>
Overshoot is occurring.		Increase the settings for C5-01 (Speed Control Proportional Gain 1) and reduce C5-02 (Speed Control Integral Time 1).
Incorrect speed feedback scaling when terminal RP is used as speed feedback input in V/f control.		<ul style="list-style-type: none"> <li>Set H6-02 to the value of the speed feedback signal frequency when the motor runs at the maximum speed.</li> <li>Adjust the input signal using parameters H6-03 through H6-05.</li> </ul>
Inappropriate parameter settings.		Check the setting for the overspeed detection level and the overspeed detection time (F1-08 and F1-09).
Resolver cable is disconnected.		Reconnect the cable.

Table 7 Operation Error Displays, Causes, and Possible Solutions

Digital Operator Display		Fault Name
oPE02	oPE02	Parameter Range Setting Error
		Use U1-18 to find parameters set outside range.
<b>Cause</b>		<b>Possible Solution</b>
Parameters were set outside the possible range.		Set parameters to the proper values. <b>Note:</b> When multiple errors occur simultaneously, other errors are given precedence over oPE02.
Digital Operator Display		Fault Name
oPE06	oPE06	Control Method Selection Error
		Correct the setting for the control method.
<b>Cause</b>		<b>Possible Solution</b>
Control mode requires installing a resolver option, but no resolver option is installed (A1-02 = 7).		Connect a resolver option.

## ◆ Preventing Noise Interference

Take the following steps to prevent erroneous operation caused by noise interference:

- Use shielded wire for the resolver signal lines.
- Limit the length of all motor output power cables to less than 10 m.
- Use separate conduit or cable tray dividers to separate option control wiring, main circuit input power wiring, and motor output power cables.
- Ground the shield on the resolver side and the drive side. If noise problems arise in the resolver signal, verify that the shield is properly grounded and ground one end of the signal line or remove the ground connection on both ends.

# 8 Specifications

**Table 8 Option Specifications**

Items	Specifications
<b>Option Model</b>	PG-RT3
<b>Resolver Model</b>	Yaskawa recommends resolver PN: TS2640N321E64 by Tamagawa Seiki Co., Ltd. <ul style="list-style-type: none"> <li>• Input voltage: AC 7 Vrms 10 kHz</li> <li>• Transformation ratio [K]: <math>0.5 \pm 5\%</math></li> <li>• Input current: 100 mA rms max.</li> </ul> <b>Note:</b> A resolver meeting or exceeding specifications in this table is also suitable for use. Contact Yaskawa for the information of other compatible resolvers.
<b>Transformation Resolution</b>	4096 p/rev
<b>Transformation accuracy</b>	$\pm 4$ LSB (absolute value at stop)
<b>Repeatability</b>	$\pm 2$ LSB (simulates 1024 p/rev encoder)
<b>Max. Revolution</b>	24000 rpm
<b>Encoder Wiring Length</b>	10 m (32 ft.) maximum
<b>Compatible Control Mode</b>	Closed Loop Vector for PM motors
<b>Pulse Monitor Output</b>	Monitor for A , B , and Z channels pulse output: Matches RS-422 level
<b>Resolver Disconnect Detection</b>	Available
<b>Ambient Temperature</b>	-10°C to 50°C (14°F to 122°F)
<b>Humidity</b>	95% RH or lower with no condensation
<b>Storage Temperature</b>	-20°C to 60°C (-4°F to 140°F) allowed for short-term transport of the product
<b>Area of Use</b>	Indoor (free of corrosive gas, airborne particles, etc.)
<b>Altitude</b>	1000 m (3280 ft.) or lower

---



## ◆ Revision History

Revision dates and manual numbers appear on the bottom of the back cover.

MANUAL NO. TOBP C730600 53A

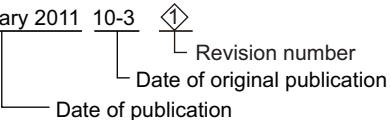
Published in Japan February 2011 10-3 



Date of Publication	Rev. No	Section	Revised Content
July 2011		Chapter 2, 5, and 8	Revision: Revised in accordance with software and hardware upgrade.
February 2011		Front cover	Revision: Format
		Back cover	Revision: Address, format
March 2010	—	—	First edition

# YASKAWA AC Drive 1000-Series Option Motor Feedback Resolver TS2640N321E64 Interface Installation Manual

---

## **DRIVE CENTER (INVERTER PLANT)**

2-13-1, Nishimiyachi, Yukuhashi, Fukuoka, 824-8511, Japan  
Phone: 81-930-25-3844 Fax: 81-930-25-4369  
<http://www.yaskawa.co.jp>

## **YASKAWA ELECTRIC CORPORATION**

New Pier Takeshiba South Tower, 1-16-1, Kaigan, Minatoku, Tokyo, 105-6891, Japan  
Phone: 81-3-5402-4502 Fax: 81-3-5402-4580  
<http://www.yaskawa.co.jp>

## **YASKAWA AMERICA, INC.**

2121 Norman Drive South, Waukegan, IL 60085, U.S.A.  
Phone: (800) YASKAWA (927-5292) or 1-847-887-7000 Fax: 1-847-887-7310  
<http://www.yaskawa.com>

## **YASKAWA ELÉTRICO DO BRASIL LTDA.**

Avenda Fagundes Filho, 620 Bairro Saude, São Paulo, SP04304-000, Brasil  
Phone: 55-11-3585-1100 Fax: 55-11-5581-8795  
<http://www.yaskawa.com.br>

## **YASKAWA EUROPE GmbH**

Hauptstrasse 185, 65760 Eschborn, Germany  
Phone: 49-6196-569-300 Fax: 49-6196-569-398  
<http://www.yaskawa.eu.com>

## **YASKAWA ELECTRIC UK LTD.**

1 Hunt Hill Orchardton Woods, Cumbernauld, G68 9LF, United Kingdom  
Phone: 44-1236-735000 Fax: 44-1236-458182  
<http://www.yaskawa.co.uk>

## **YASKAWA ELECTRIC KOREA CORPORATION**

7F, Doore Bldg. 24, Yeoido-dong, Yeongdungpo-gu, Seoul, 150-877, Korea  
Phone: 82-2-784-7844 Fax: 82-2-784-8495  
<http://www.yaskawa.co.kr>

## **YASKAWA ELECTRIC (SINGAPORE) PTE. LTD.**

151 Lorong Chuan, #04-01, New Tech Park, 556741, Singapore  
Phone: 65-6282-3003 Fax: 65-6289-3003  
<http://www.yaskawa.com.sg>

## **YASKAWA ELECTRIC (SHANGHAI) CO., LTD.**

No. 18 Xizang Zhong Road, 17F, Harbour Ring Plaza, Shanghai, 200001, China  
Phone: 86-21-5385-2200 Fax: 86-21-5385-3239  
<http://www.yaskawa.com.cn>

## **YASKAWA ELECTRIC (SHANGHAI) CO., LTD. BEIJING OFFICE**

Room 1011, Tower W3 Oriental Plaza, No. 1 East Chang An Ave.,  
Dong Cheng District, Beijing, 100738, China  
Phone: 86-10-8518-4086 Fax: 86-10-8518-4082

## **YASKAWA ELECTRIC TAIWAN CORPORATION**

9F, 16, Nanking E. Rd., Sec. 3, Taipei, 104, Taiwan  
Phone: 886-2-2502-5003 Fax: 886-2-2505-1280



YASKAWA ELECTRIC CORPORATION

In the event that the end user of this product is to be the military and said product is to be employed in any weapons systems or the manufacture thereof, the export will fall under the relevant regulations as stipulated in the Foreign Exchange and Foreign Trade Regulations. Therefore, be sure to follow all procedures and submit all relevant documentation according to any and all rules, regulations and laws that may apply.

Specifications are subject to change without notice for ongoing product modifications and improvements.

© 2010-2011 YASKAWA ELECTRIC CORPORATION. All rights reserved.

MANUAL NO. TOBP C730600 53B

Published in Japan July 2011 10-3 -0  
10-10-6