

YASKAWA AC Drive Option

EtherNet/IP

Technical Manual

Model SI-EN3D

To correctly use the product, read this manual thoroughly and keep it for easy reference, inspection, and maintenance. Make sure that the end user receives this manual.

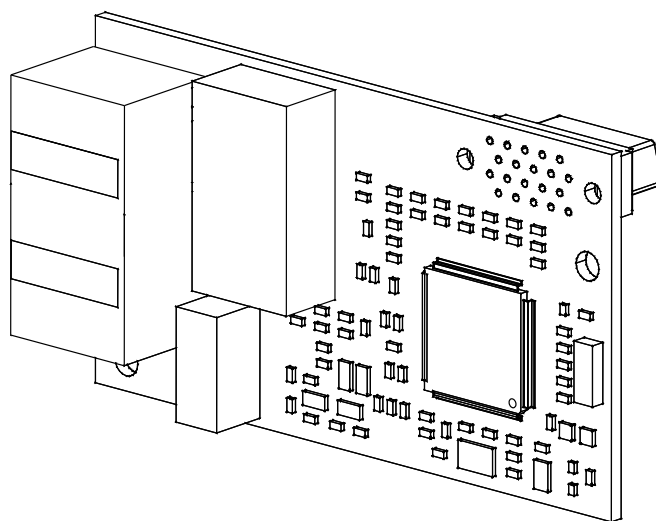

This Page Intentionally Blank

Table of Contents

1. Preface and Safety	8
Applicable Documentation	8
Glossary	8
Registered Trademarks	8
Supplemental Safety Information	8
Section Safety	9
2. Overview	9
Compatible Products	9
Install the Option on a GA500 Drive	10
3. Receiving	11
Option Package Contents	11
Installation Tools	12
4. Option Components	12
Option	12
Communication Modular Connector CN1 Port 1/Port 2	12
Option LED States	13
Power-Up Diagnostics	14
5. Installation Procedure	14
Section Safety	14
Procedures to Install and Wire Options on a Drive	15
Procedure A	15
Procedure B	18
Procedure C	22
Procedure D	25
IGMP Snooping	30
Communication Cable Specifications	30
Option Connection Diagram	31
Communication Cable Specifications	31
EDS Files	31
6. Related Drive Parameters	32
7. EtherNet/IP Configuring Messaging	37
Drive Polled Configuration	37
Converter Polled Configuration	37
8. Output Assemblies (Drive Consumes)	38

EtherNet/IP Basic Speed Control Output - 20 (0x14)	38
EtherNet/IP Extended Speed Control Output - 21 (0x15).	38
EtherNet/IP Speed and Torque Control Output - 22 (0x16)	39
EtherNet/IP Extended Speed and Torque Control Output - 23 (0x17).	40
MEMOBUS/Modbus Message Output (Vendor Specific Yaskawa Electric (YE) Assy) - 100 (0x64)	40
(Vendor Specific Yaskawa Electric (YE) Assy) Speed/Torque Control Output - 101 (0x65)	41
(Vendor Specific Yaskawa Electric (YE) Assy) Extended Speed/Torque Control Output - 115 (0x73)	42
(Vendor Specific Yaskawa Electric (YE) Assy)-High Speed/Torque Control Output - 116 (0x74)	44
(Vendor Specific Yaskawa Electric (YE) Assy) 8 Byte Dynamic Output - 117 (0x75)	46
(Vendor Specific Yaskawa Electric (YE) Assy) 12 Byte Dynamic Output - 118 (0x76) . . .	47
(Vendor Specific Yaskawa Electric (YE) Assy) 18 Byte Dynamic Output - 119 (0x77) . . .	48
(Vendor Specific Yaskawa Electric (YE) Assy) 24 Byte Dynamic Output - 120 (0x78)	49
9. Input Assemblies (Drive Produces)	51
EtherNet/IP Basic Speed Control Input - 70 (0x46).	51
EtherNet/IP Extended Speed Control Input - 71 (0x47)	51
EtherNet/IP Speed and Torque Control Input - 72 (0x48).	52
EtherNet/IP Extended Speed and Torque Control Input - 73 (0x49)	52
(Vendor Specific Yaskawa Electric (YE) Assy) MEMOBUS/Modbus Message Input - 150 (0x96)	53
(Vendor Specific Yaskawa Electric (YE) Assy) Speed/Torque Status Input - 151 (0x97)	54
(Vendor Specific Yaskawa Electric (YE) Assy) Extended Speed/Torque Status Input - 155 (0x9B)	55
(Vendor Specific Yaskawa Electric (YE) Assy) High Speed/Torque Status Input - 166 (0xA6)	58
(Vendor Specific Yaskawa Electric (YE) Assy) 8-Byte Dynamic Input - 167 (0xA7)	61
(Vendor Specific Yaskawa Electric (YE) Assy) 12-Byte Dynamic Input - 168 (0xA8)	62
(Vendor Specific Yaskawa Electric (YE) Assy) 18-Byte Dynamic Input - 169 (0xA9)	63
(Vendor Specific Yaskawa Electric (YE) Assy) 24-Byte Dynamic Input - 170 (0xAA)	65
10. Output Assemblies (Converter Consumes)	66
EtherNet/IP Basic Speed Control Output - 20 (0x14)	66
EtherNet/IP Extended Speed Control Output - 21 (0x15).	67
EtherNet/IP Speed and Torque Control Output - 22 (0x16)	68
EtherNet/IP Extended Speed and Torque Control Output - 23 (0x17).	68
(Vendor Specific Yaskawa Electric (YE) Assy) Speed/Torque Control Output - 101 (0x65)	69
(Vendor Specific Yaskawa Electric (YE) Assy) Extended Speed/Torque Control Output - 115 (0x73)	70
(Vendor Specific Yaskawa Electric (YE) Assy)-High Speed/Torque Control Output - 116 (0x74)	71
(Vendor Specific Yaskawa Electric (YE) Assy) 8 Byte Dynamic 2 Output - 117 (0x75)	74
(Vendor Specific Yaskawa Electric (YE) Assy) 12 Byte Dynamic 4 Output - 118 (0x76)	75

(Vendor Specific Yaskawa Electric (YE) Assy) 18 Byte Dynamic 7 Output - 119 (0x77)	76
(Vendor Specific Yaskawa Electric (YE) Assy) 24 Byte Dynamic 10 Output - 120 (0x78)	77
11. Input Assemblies (Converter Produces)	79
EtherNet/IP Basic Speed Control Input - 70 (0x46)	79
EtherNet/IP Extended Speed Control Input - 71 (0x47)	79
EtherNet/IP Speed and Torque Control Input - 72 (0x48)	80
EtherNet/IP Extended Speed and Torque Control Input - 73 (0x49)	80
(Vendor Specific Yaskawa Electric (YE) Assy) Speed/Torque Status Input - 151 (0x97)	81
(Vendor Specific Yaskawa Electric (YE) Assy) Extended Speed/Torque Status Input - 155 (0x9B)	82
(Vendor Specific Yaskawa Electric (YE) Assy) High Speed/Torque Status Input - 166 (0xA6)	84
(Vendor Specific Yaskawa Electric (YE) Assy) 8-Byte Dynamic Input 2 - 167 (0xA7)	87
(Vendor Specific Yaskawa Electric (YE) Assy) 12-Byte Dynamic Input 4 - 168 (0xA8)	88
(Vendor Specific Yaskawa Electric (YE) Assy) 18-Byte Dynamic Input 7 - 169 (0xA9)	90
(Vendor Specific Yaskawa Electric (YE) Assy) 24-Byte Dynamic Input 10 - 170 (0xAA)	91
12. General Class Objects (Drive)	93
Identity Object - 1 (Class 0x01)	93
Services Supported	93
Attributes Supported	93
Assembly Object - 4 (Class 0x04)	94
Services Supported	94
Attributes Supported	94
Motor Data Object - 40 (Class 0x28)	95
Services Supported	95
Attributes Supported	95
Control Supervisor Object - 41 (Class 0x29)	95
Services Supported	96
Attributes Supported	96
Option Fault Code Conversion Table	97
AC/DC Drive Object - 42 (Class 0x2A)	98
Services Supported	98
Attributes Supported	98
DLR Object 71 (Class 0x47)	100
Services Supported	100
Attributes Supported	100
QoS Object 72 (Class 0x48)	101
Services Supported	101
Attributes Supported	101
Base Energy Object 78 (Class 0x4E)	101
Services Supported	101
Attributes Supported	102
Electrical Energy Object 79 (Class 0x4F)	102
Services Supported	102
Attributes Supported	102

TCP/IP Object 245 (Class 0xF5)	103
Services Supported	103
Attributes Supported	103
Ethernet Link Object 246 (Class 0xF6)	104
Services Supported	104
Attributes Supported	104
13. General Class Objects (Converter)	106
Motor Data Object - 40 (Class 0x28)	106
Services Supported	106
Attributes Supported	106
Control Supervisor Object 41 (Class 0x29)	106
Services Supported	106
Attributes Supported	106
AC/DC Drive Object - 42 (Class 0x2A)	107
Services Supported	107
Attributes Supported	107
Base Energy Object 78 (Class 0x4E)	108
Services Supported	108
Attributes Supported	108
Electrical Energy Object 79 (Class 0x4F)	109
Services Supported	109
Attributes Supported	109
14. Vendor-Specific (Yaskawa) Class Objects	109
Yaskawa Drive Parameters Object - 100 (Class 0x64)	109
Services Supported	109
Storing Changed Parameters	110
Attributes Supported	110
Yaskawa Monitor/Control Object - 125 (Class 0x7D)	110
Services Supported	110
Attributes Supported	111
15. Web Interface	111
Home Page	111
EtherNet/IP Page	112
Network Page	113
Ring Page	114
Chart Page	115
Email Alerts Page	115
Parameter Access Page	116
Settings Page	117
16. Troubleshooting	117
Drive-Side Error Codes	117
Faults	118
Minor Faults and Alarms	118
bUS Fault Tolerance	119
bUS Fault Auto-Restart	119
bUS Fault Delay	119
Explicit Message Communications Errors	119
Option Error Codes	119
Option Fault Monitors <i>U6-98</i> and <i>U6-99</i>	119

Option Compatibility	120
17. Option Installation	120
18. Specifications	122
Specifications	122
19. Disposal	122
Disposal Instructions	122
WEEE Directive	123
Revision History	124

1 Preface and Safety

YASKAWA Electric supplies component parts for use in a wide variety of industrial applications. The selection and application of YASKAWA products remain the responsibility of the equipment designer or end user.

YASKAWA accepts no responsibility for the way its products are incorporated into the final system design. Under no circumstances should any YASKAWA product be incorporated into any product or design as the exclusive or sole safety control. Without exception, all controls should be designed to detect faults dynamically and fail safely under all circumstances. All products designed to incorporate a component part manufactured by YASKAWA must be supplied to the end user with appropriate warnings and instructions as to the safe use and operation of that part. Any warnings provided by YASKAWA must be promptly provided to the end user. YASKAWA offers an express warranty only as to the quality of its products in conforming to standards and specifications published in the manual. **NO OTHER WARRANTY, EXPRESS OR IMPLIED, IS OFFERED.** YASKAWA assumes no liability for any personal injury, property damage, losses, or claims arising from misapplication of its products.

◆ Applicable Documentation

Document	Description
YASKAWA AC Drive Option EtherNet/IP Installation Manual	Read this manual first. The manual provides information about wiring, settings, functions, and troubleshooting. The manual is packaged together with the product.
YASKAWA AC Drive Option EtherNet/IP Technical Manual Manual No.: SIEP C730600 0D (This book)	The technical manual contains detailed information about the option. Access the following sites to obtain the technical manual: U.S.: http://www.yaskawa.com Europe: http://www.yaskawa.eu.com Japan: http://www.e-mechatronics.com Other areas: Check the back cover of these manuals. For questions, contact Yaskawa or a Yaskawa representative.
YASKAWA AC Drive Manuals	Refer to the drive manual to connect with the option. Drive manuals contain basic installation and wiring information in addition to detailed parameter setting, fault diagnostic, and maintenance information. The manuals also include important information about parameter settings and tuning the drive. The Quick Start Guides are packaged with the drive. The most recent versions of these manuals are available for download on our documentation websites: U.S.: http://www.yaskawa.com Europe: http://www.yaskawa.eu.com Japan: http://www.e-mechatronics.com Other areas: Check the back cover of these manuals. For questions, contact Yaskawa or a Yaskawa representative.

◆ Glossary

Term	Definition
Option	YASKAWA AC Drive Option SI-EN3D EtherNet/IP
Keypad	<ul style="list-style-type: none"> • HOA Operator • LCD Operator • LED Operator • HOA Keypad • LCD Keypad • LED Keypad
Hex. (Example: 900 (Hex.))	Identifies a unit for hexadecimal number format.

◆ Registered Trademarks

- EtherNet/IP is a registered trademark of Open DeviceNet Vendor Association, Inc. (ODVA).
- Trademarks are the property of their respective owners.

◆ Supplemental Safety Information

Read and understand this manual before installing, operating, or servicing this option. The option must be installed according to this manual and local codes.

The following conventions are used to indicate safety messages in this manual. Failure to heed these messages could result in serious or possibly even fatal injury or damage to the products or to related equipment and systems.

- ⚠ DANGER** This signal word identifies a hazard that will cause serious injury or death if you do not prevent it.
- ⚠ WARNING** This signal word identifies a hazard that can cause death or serious injuries if you do not prevent it.
- ⚠ CAUTION** This signal word identifies a hazardous situation, which, if not avoided, can cause minor or moderate injury.
- NOTICE** This signal word identifies a property damage message that is not related to personal injury.

■ Section Safety

General Precautions
<ul style="list-style-type: none"> The diagrams in this section may include options and drives without covers or safety shields to illustrate details. Be sure to reinstall covers or shields before operating any devices. The option should be used according to the instructions described in this manual. The diagrams in this manual are provided as examples only and may not pertain to all products covered by this manual. The products and specifications described in this manual or the content and presentation of the manual may be changed without notice to improve the product and/or the manual. Contact Yaskawa or a Yaskawa representative and provide the manual number shown on the front cover to order new copies of the manual.

- ⚠ DANGER** Do not ignore the safety messages in this manual. If you ignore the safety messages in this manual, it will cause serious injury or death. The manufacturer is not responsible for injuries or damage to equipment.
- ⚠ WARNING** *Electrical Shock Hazard.* Do not modify the drive or option circuitry. Failure to obey can cause serious injury or death, or cause damage to the drive or option and will void warranty. Yaskawa is not responsible for modifications of the product made by the user.
- NOTICE** *Damage to Equipment.* Do not use steam or other disinfectants to fumigate wood for packaging the drive. Use alternative methods, for example heat treatment, before you package the components. Gas from wood packaging fumigated with halogen disinfectants, for example fluorine, chlorine, bromine, iodine or DOP gas (phthalic acid ester), can cause damage to the drive.

2 Overview

This option provides a communications connection between the drive and an EtherNet/IP network. The option connects the drive to an EtherNet/IP network and facilitates the exchange of data.

EtherNet/IP is a communications link to connect industrial devices (for example smart motor controllers, operator interfaces, and variable frequency drives) and control devices (for example, programmable controllers and computers) to a network. EtherNet/IP is a simple networking solution. EtherNet/IP decreases the cost and time to wire and install factory automation devices, and it gives the option to interchange like components from other vendors.

EtherNet/IP is an open network standard.

Install the option on a drive to perform the following functions from an EtherNet/IP master device:

- Operate the drive
- Monitor the drive operation status
- Change drive parameter settings

◆ Compatible Products

You can use the option with these products:

Table 2.1 Compatible Products

Drive	Model	Software Version ^{*1}
A1000	CIMR-Ax2Axxxx	≥ 1020
	CIMR-Ax4A0002 - 4A0675	
	CIMR-Ax4A0930, 4A1200	≥ 3010
	CIMR-Ax5Axxxx	≥ 5040 ≥ 1017
D1000	CIMR-Dx2A0005 - 4A0370	≥ 2600
	CIMR-Dx4A0630	≥ 3014
R1000	CIMR-Rx2A03P5 - 4A0300	≥ 2102
U1000	CIMR-UxxAxxxx	≥ 1015
	CIMR-UxxExxxx	
	CIMR-UxxPxxxx	

Drive	Model	Software Version ^{*1}
	CIMR-UxxWxxxx	
U1000L	CIMR-UxxLxxxx	≥ 6210
	CIMR-UxxFxxxx	
	CIMR-UxxRxxxx	
	CIMR-UxxSxxxx	
	CIMR-UxxSxxxx	
Z1000	CIMR-ZxxAxxxx	≥ 1014
Z1000U	CIMR-ZxxUxxxx	≥ 6113
	CIMR-ZxxExxxx	
	CIMR-ZxxPxxxx	
	CIMR-ZxxWxxxx	
GA500 ^{*2}	CIPR-GA50xxxxx	≥ 1010
GA700 ^{*2}	CIPR-GA70xxxxx	≥ 1010
GA800 ^{*2}	CIPR-GA80xxxxx	≥ 9010
HV600 ^{*2}	CIPR-HV60xxxxx	≥ 1011
FP605 ^{*3}	CIPR-FP65xxxxx	≥ 1010

- *1 Refer to “PRG” on the drive nameplate for the software version number.
- *2 Before you install the option on a GA500, GA700, GA800, or HV600 drive, make sure that the option software version is PRG: 0345 or later.
- *3 Before you install the option on an FP605 drive, make sure that the option software version is PRG: 0347 or later.

Note:

- Refer to the option package labeling in the field designated “PRG (four digit number)” to identify the option software version.
- For Yaskawa customers in the North or South America regions:
If your product is not listed in [Table 2.1](#), refer to the web page below to confirm this manual is correct for your product. The web page provides a list of option manuals by product, and a direct link to download a PDF of the manual.

Scan QR code Or refer to:

<http://www.yaskawa.com/optionlookup>



◆ **Install the Option on a GA500 Drive**

An option card mounting kit is necessary to install the option on a GA500 drive. The option card mounting kit model is: JOHB-GA50. This kit is sold separately.

Refer to the option card mounting kit manual for more information about installation.

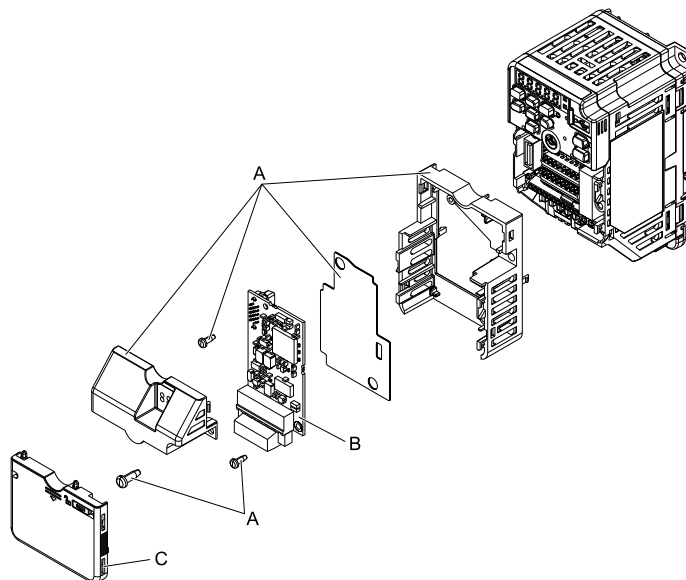

A - Option card mounting kit components (sold separately) **C - Drive front cover**
B - Option

Figure 2.1 Option Card Mounting Kit (JOHB-GA50)

3 Receiving

After receiving the option package:





- Make sure that the option is not damaged and no parts are missing. The Yaskawa warranty does not include damage from shipping. Contact your sales outlet if there is damage to the option or other parts.

NOTICE *Damage to Equipment. Do not use damaged parts to connect the drive and the option. Failure to comply could damage the drive and option.*

- Make sure that the model number on the option nameplate and the model number on the purchase order are the same. Refer to [Figure 4.1](#) for more information.
- Contact the distributor where you purchased the option or contact Yaskawa or a Yaskawa representative about any problems with the option.

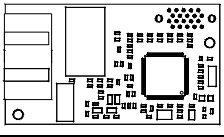
◆ Option Package Contents

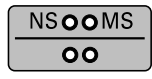
Table 3.1 Contents of Package

Option Contents		Quantity
Option		1
Ground Wire <i>*1</i>		1
Screws (M3)		3 <i>*2</i>
LED label	1000-Series, Z1000U 	1
	GA500, GA700, GA800 	1

4 Option Components

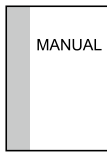
Option Contents		Quantity
	Z1000, HV600, and FP605 *3	1 *4
Manuals		1

*1 GA500, GA700, and GA800 drives do not use the ground wire.

*2 GA700, GA800, HV600, and FP605 drives use two screws only.

*3 LED label has transparent background and white letters. Please make sure that you use the correct label for Z1000, HV600, or FP605.

*4 Options purchased in Japan do not include LED labels for Z1000, HV600, or FP605.

◆ Installation Tools

You can use these tools to install the option to the drive:

- A Phillips screwdriver or slotted screwdriver (blade depth: 0.4 mm (0.02 in), width: 2.5 mm (0.1 in)) *1.
- A pair of diagonal cutting pliers.
- A small file or medium-grit sandpaper.

*1 Phillips screw sizes are different for different drive capacities. Prepare different screwdrivers for different screw sizes.

4 Option Components

◆ Option

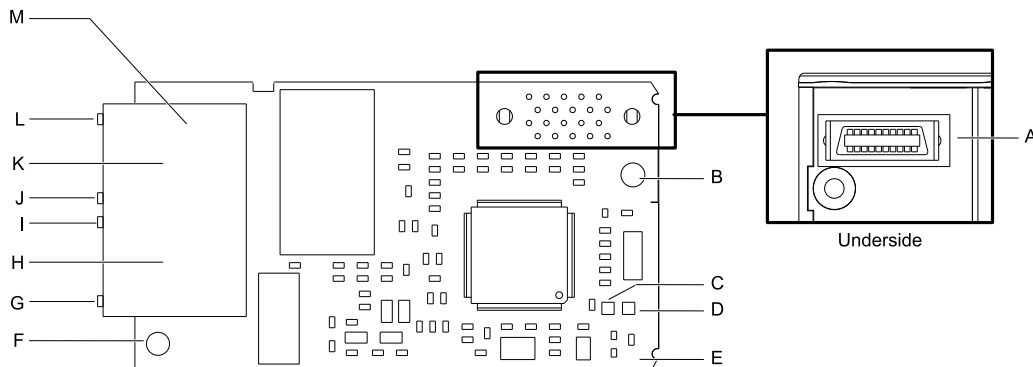

A - Connector (CN5)

B - Installation hole

C - LED (NS) *1

D - LED (MS) *1

E - Option PCB

F - Ground terminal (FE) and installation hole *2

G - Port 1 LED (10/100) *1

H - Option modular connector CN1 port 1 (RJ45)

I - Port 1 LED (LINK/ACT) *1

J - Port 2 LED (10/100) *1

K - Option modular connector CN1 port 2 (RJ45)

L - Port 2 LED (LINK/ACT) *1

M - Communication connector CN1

Figure 4.1 Option

*1 Refer to [Option LED States on page 13](#) for more information about the LEDs.

*2 Connect the included ground wire during installation. The ground wire is not necessary for installation on GA700 and GA800 drives. For GA500, connect the included ground wire to the separately sold communication option case (model: JOHB-GA50).

◆ Communication Modular Connector CN1 Port 1/Port 2

The communication modular connector CN1 on the option is a modular dual RJ45 female connector designated port 1 and port 2. Port 1 and port 2 are the connection points for a customer-supplied male EtherNet/IP network communication cable.

Table 4.1 Male 8-way Ethernet Modular Connector (Customer-Supplied)

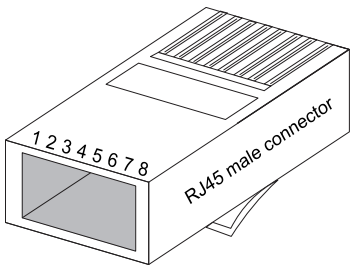
Male EtherNet 8-Way Modular Connector	Pin	Description
	1 (Pair 2)	Transmit data (TXD) +
	2 (Pair 2)	Transmit data (TXD) -
	3 (Pair 3)	Receive data (RXD) +
	4 (Pair 1)	Not used ^{*/}
	5 (Pair 1)	Not used ^{*/}
	6 (Pair 3)	Receive data (RXD) -
	7 (Pair 4)	Not used ^{*/}
	8 (Pair 4)	Not used ^{*/}

*1 Not used for 10 Mbps and 100 Mbps networks.

◆ Option LED States

The option has four LEDs:

- Bi-color Status LEDs:
 - Module status (MS) red/green
 - Network status (NS) red/green
- Ethernet LEDs:
 - Network speed-10/100 yellow
 - Link status and network activity-Link/Act green

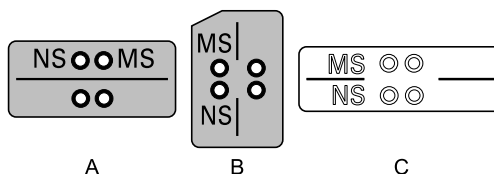

A - 1000-Series, Z1000U
B - GA500, GA700, GA800

C - Z1000, HV600, and FP605 ^{*/}

Figure 4.2 Option LED Labels

*1 LED label has transparent background and white letters. Please make sure that you use the correct label for Z1000, HV600, or FP605.

Wait 2 seconds minimum for the power-up diagnostic process to complete before you verify the LED states. The [Table 4.2](#) shows the operating status of the option LEDs after the power-up diagnostic LED sequence is complete. Refer to [Table 4.3](#) for more information about the LEDs.

Table 4.2 Option LED States

LED Name	Indication		Operating State	Description
	Color	Display		
MS	-	OFF	Power supply off	There is no power to the drive.
	Green	ON	Option operating	The option is operating normally.
	Green	Flashing	Option initializing	The option is configuring an IP address.
	Red	ON	Fatal error occurred	The option detected a fatal (unrecoverable) error.
	Red	Flashing	Non-fatal error occurred	The option detected a non-fatal (recoverable) error.
	Red/Green	Flashing	Option self-test	The option is in self-test mode.
NS	-	OFF	Power supply OFF or Offline	-
	Green	ON	Online communications established	The option is online and has established connections.
	Green	Flashing	Online communications not established	The option is online without an established connection.
	Red	ON	Communications error (fatal)	The option detected a duplicate IP address.
	Red	Flashing	Communications time-out (non-fatal)	A communications time-out occurred.
	Red/Green	Flashing	Option self-test	The option is in self-test mode.

5 Installation Procedure

LED Name	Indication		Operating State	Description
	Color	Display		
10/100 */	Yellow	OFF	10 Mbps is established	
	Yellow	ON	100 Mbps is established	
LINK/ACT */	Green	OFF	Link is not established	
	Green	ON	Link is established	
	Green	Flashing	Link is established and there is network activity	

*1 To verify LED states, you must remove the drive front cover. Do not touch the drive main circuit terminal or circuit boards when you remove the drive front cover.

■ Power-Up Diagnostics

An LED test is performed each time the drive is powered up. The initial boot sequence can take several seconds. After the LEDs complete the diagnostic LED sequence, the option is successfully initialized. The LEDs then assume operational conditions as shown in [Table 4.3](#).

Table 4.3 Power-Up Diagnostic LED Sequence

Sequence	Module Status (MS)	Network Status (NS)	Time (ms)
1	Green	OFF	250
2	Red	OFF	250
3	Green	OFF	-
4	Green	Green	250
5	Green	Red	250
6	Green	OFF	-

5 Installation Procedure

◆ Section Safety

⚠ DANGER *Electrical Shock Hazard. Do not examine, connect, or disconnect wiring on an energized drive. Before servicing, disconnect all power to the equipment and wait for the time specified on the warning label at a minimum. The internal capacitor stays charged after the drive is de-energized. The charge indicator LED extinguishes when the DC bus voltage decreases below 50 Vdc. When all indicators are OFF, measure for dangerous voltages to make sure that the drive is safe. If you do work on the drive when it is energized, it will cause serious injury or death from electrical shock.*

⚠ WARNING *Electrical Shock Hazard. Do not operate the drive when covers are missing. Replace covers and shields before you operate the drive. Use the drive only as specified by the instructions. Some figures in this section include drives without covers or safety shields to more clearly show the inside of the drive. If covers or safety shields are missing from the drive, it can cause serious injury or death.*

⚠ WARNING *Electrical Shock Hazard. Only let approved personnel install, wire, maintain, examine, replace parts, and repair the drive. If personnel are not approved, it can cause serious injury or death.*

⚠ WARNING *Electrical Shock Hazard. Do not remove covers or touch circuit boards while the drive is energized. If you touch the internal components of an energized drive, it can cause serious injury or death.*

⚠ WARNING *Electrical Shock Hazard. Do not use damaged wires, put too much force on the wiring, or cause damage to the wire insulation. Damaged wires can cause serious injury or death.*

⚠ WARNING *Fire Hazard. Tighten all terminal screws to the correct tightening torque. Connections that are too loose or too tight can cause incorrect operation and damage to the drive. Incorrect connections can also cause death or serious injury from fire.*

NOTICE *Damage to Equipment. When you touch the option, make sure that you observe correct electrostatic discharge (ESD) procedures. If you do not follow procedures, it can cause ESD damage to the drive circuitry.*

NOTICE *Damage to Equipment. Do not de-energize the drive while the drive is outputting voltage. Incorrect equipment sequencing can cause damage to the drive.*

NOTICE *Do not operate a drive or connected equipment that has damaged or missing parts. You can cause damage to the drive and connected equipment.*

NOTICE *Use Yaskawa connection cables or recommended cables only. Incorrect cables can cause the drive or option to function incorrectly.*

NOTICE *Damage to Equipment. Correctly connect the connectors. Incorrect connections can cause malfunction or damage to the equipment.*

NOTICE *Damage to Equipment. Make sure that all connections are correct after you install the drive and connecting peripheral devices. Incorrect connections can cause damage to the option.*

◆ Procedures to Install and Wire Options on a Drive

Refer to the following table to check the procedures to install and wire the option on a drive.

Table 5.1 Procedures to Install and Wire Options on a Drive

Drive	Procedures to Install and Wire Options on a Drive	Reference Page
A1000	Procedure A	15
D1000	Procedure A	15
R1000	Procedure A	15
U1000	Procedure A	15
U1000L	Procedure A	15
Z1000U	Procedure A	15
Z1000	Procedure B	18
GA500	*1 *2	-
GA700	Procedure C	22
GA800	Procedure C	22
HV600	Procedure D	25
FP605	Procedure D	25

*1 To install the option on GA500 drives, use the option mounting kit (JOHB-GA50) and manual.

*2 Before you install the option on a GA500 drive, make sure that the option software version is PRG: 0345 or later.

■ Procedure A

This section shows the procedure to install and wire the option on a 1000-series drive.

Prepare the Drive for the Option

Correctly wire the drive as specified by the manual packaged with the drive. Make sure that the drive functions correctly. Refer to the drive manuals for more information.

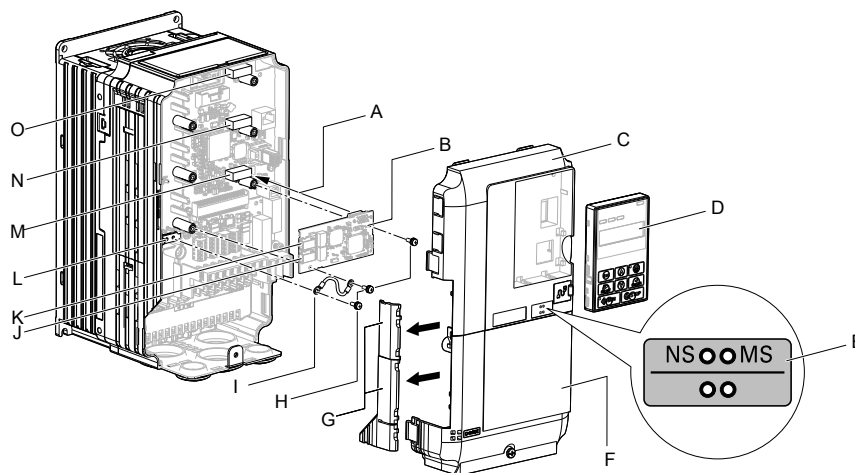

A - Insertion point for CN5 connector

B - Option

C - Drive front cover

D - Keypad

E - LED label

F - Drive terminal cover

G - Removable tabs for wire routing

H - Included screws

I - Ground wire

J - Option modular connector CN1 port 1 (RJ45)

K - Option modular connector CN1 port 2 (RJ45)

L - Drive grounding terminal (FE)

M - Connector CN5-A

N - Connector CN5-B (Not available for communication option installation.)

O - Connector CN5-C (Not available for communication option installation.)

Figure 5.1 Drive Components with Option

Install the Option

Use this procedure to install the option.

⚠ DANGER *Electrical Shock Hazard. Do not examine, connect, or disconnect wiring on an energized drive. Before servicing, disconnect all power to the equipment and wait for the time specified on the warning label at a minimum. The internal capacitor stays charged after the drive is de-energized. The charge indicator LED extinguishes when the DC bus voltage decreases below 50 Vdc. When all indicators are OFF, measure for dangerous voltages to make sure that the drive is safe. If you do work on the drive when it is energized, it will cause serious injury or death from electrical shock.*

1. Remove the keypad (B), front cover (A), and terminal cover (C).

Shut off power to the drive and wait for the time specified on the drive warning label at a minimum. Make sure that the charge indicator LED is unlit, then remove the keypad and front cover. Refer to the drive manuals for more information.

You can only install this option into the CN5-A connector on the drive control board.

NOTICE *Damage to Equipment. When you touch the option, make sure that you observe correct electrostatic discharge (ESD) procedures. If you do not follow procedures, it can cause ESD damage to the drive circuitry.*

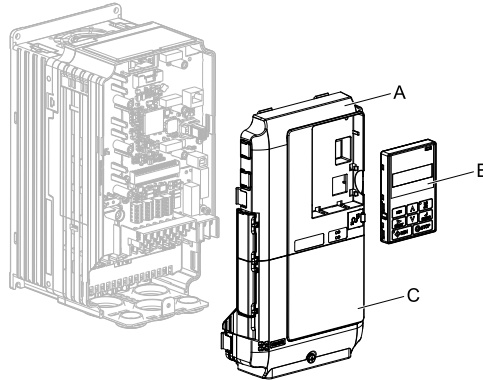

A - Drive front cover
B - Keypad

C - Drive terminal cover

Figure 5.2 Remove the Keypad, Front Cover, and Terminal Cover

2. Put the LED label (B) in the correct position on the drive front cover (A).

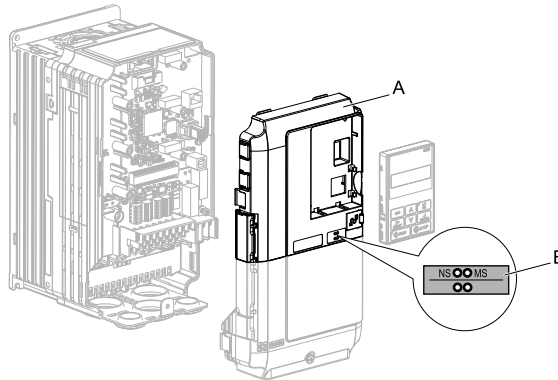

A - Drive front cover

B - LED label

Figure 5.3 Put the LED Label on the Drive Front Cover

3. Install the option (A) into the CN5-A connector (C) on the drive and use one of the included screws (B) to put it in place.

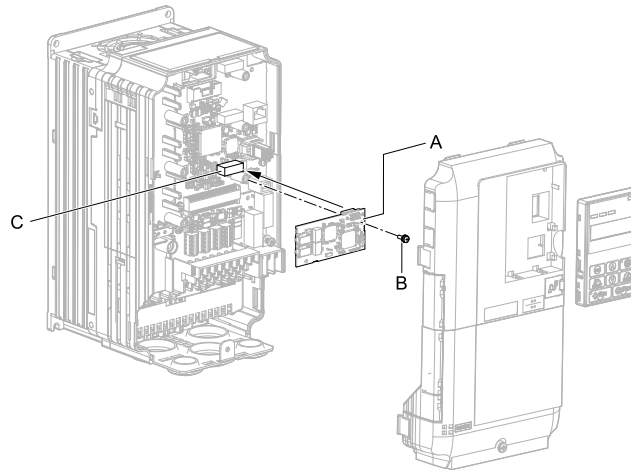

A - Option
B - Included screw

C - Connector CN5-A

Figure 5.4 Install the Option

4. Use one of the remaining included screws (B) to connect one end of the ground wire (C) to the ground terminal (D). Use the last remaining included screw (B) to connect the other end of the ground wire (C) to the remaining ground terminal and installation hole on the option (A).

Tighten the screws to a correct tightening torque:

- 0.5 N·m to 0.6 N·m (4.4 in·lb to 5.3 in·lb)

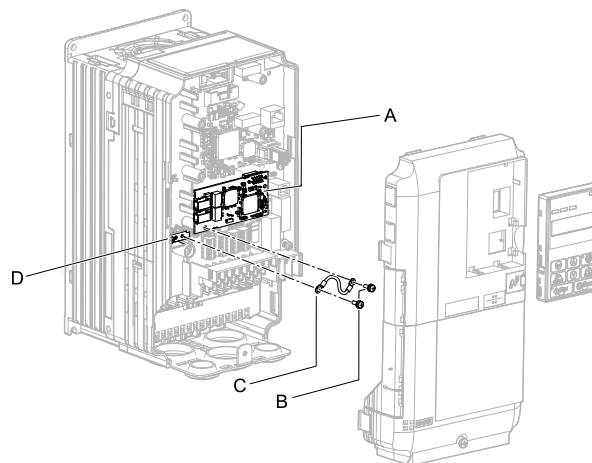

A - Option
B - Included screws

C - Ground wire
D - Drive grounding terminal (FE)

Figure 5.5 Connect the Ground Wire

Note:

The drive has only two ground terminal screw holes. When you connect three options, two options will share one ground terminal.

5. Route the option wiring.

Procedures to wire the option are different for different drive models.

- You can route the option wiring through openings on the front cover of some models. Remove the perforated tabs on the left side of the front cover as shown in [Figure 5.6-A](#) to create the necessary openings on these models. To prevent damage to the cable from the cut end, treat the cut surface with sandpaper.
- Route the option wiring inside the enclosure as shown in [Figure 5.6-B](#).

Refer to the drive manuals for more information.

Note:

Isolate communication cables from main circuit wiring and other electrical and power lines.

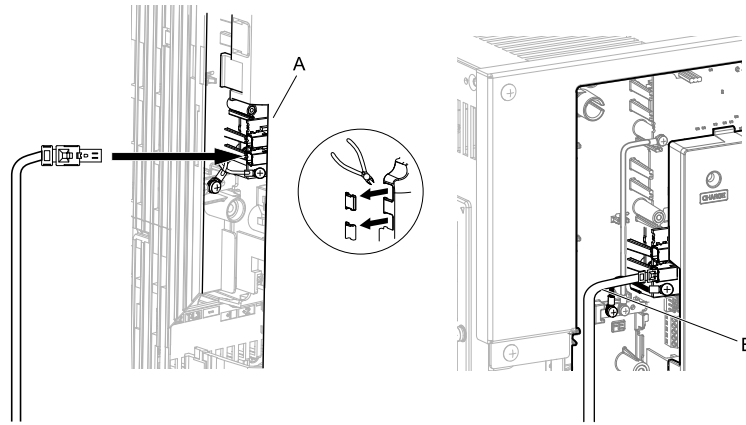

- A - Route wires through the openings provided on the left side of the front cover. ^{*}/** **B - Use the open space provided inside the drive to route option wiring.**

Figure 5.6 Wire Routing Examples

^{*}1 If there is wiring outside the enclosure, the drive will not meet Enclosed wall-mounted type (IP20/UL Type 1) requirements.

- Firmly connect the Ethernet communication cable to the option modular connector CN1 port 1 or port 2. Isolate communication cables from main circuit wiring and other electrical and power lines. Make sure that you firmly connect the cable end. (Refer to [Figure 5.28](#)). Refer to [Communication Cable Specifications on page 30](#) for more information.

NOTICE *Damage to Equipment.* When you touch the option, make sure that you observe correct electrostatic discharge (ESD) procedures. If you do not follow procedures, it can cause ESD damage to the drive circuitry.

- Reattach the front cover (A), terminal cover (C), and keypad (B). Refer to the drive manuals for more information.

NOTICE *Do not pinch cables between the front covers and the drive. Failure to comply could cause erroneous operation.*

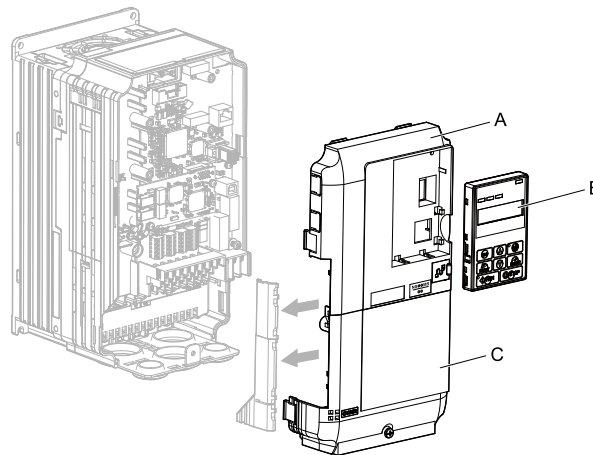

- A - Drive front cover**
B - Keypad

C - Drive terminal cover

Figure 5.7 Replace the Front Cover, Terminal Cover, and Keypad

- Set drive parameters in [Related Drive Parameters on page 32](#) for correct option performance.

■ Procedure B

This section shows the procedure to install and wire the option on a Z1000 drive.

Prepare the Drive for the Option

Correctly wire the drive as specified by the manual packaged with the drive. Make sure that the drive functions correctly. Refer to the drive manuals for more information.

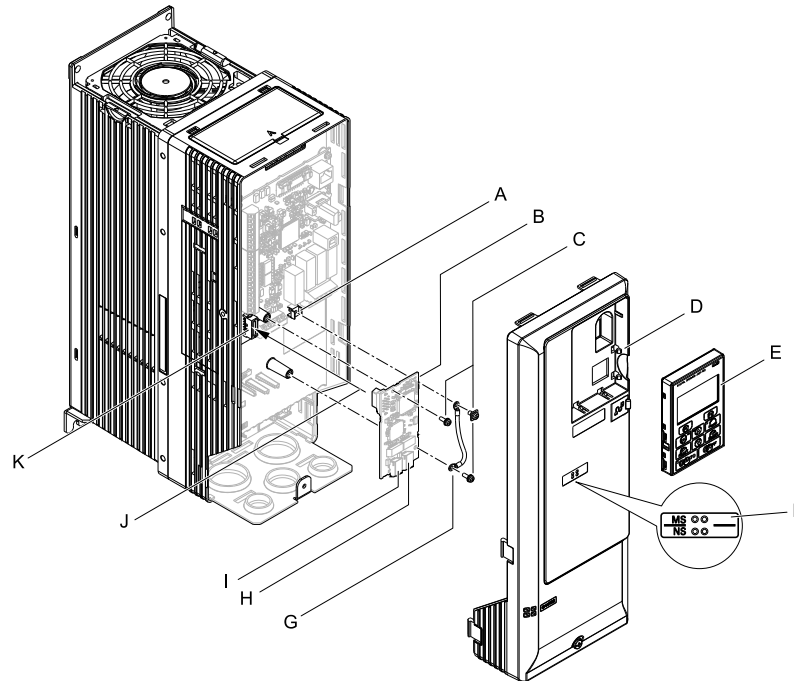

A - Drive grounding terminal (FE)

B - Option

C - Included screws

D - Drive front cover

E - Keypad

F - LED label

G - Ground wire

H - Option modular connector CN1 port 1 (RJ45)

I - Option modular connector CN1 port 2 (RJ45)

J - Insertion point for CN5 connector

K - Connector CN5

Figure 5.8 Drive Components with Option

Install the Option

Use this procedure to install the option.

⚠ DANGER *Electrical Shock Hazard. Do not examine, connect, or disconnect wiring on an energized drive. Before servicing, disconnect all power to the equipment and wait for the time specified on the warning label at a minimum. The internal capacitor stays charged after the drive is de-energized. The charge indicator LED extinguishes when the DC bus voltage decreases below 50 Vdc. When all indicators are OFF, measure for dangerous voltages to make sure that the drive is safe. If you do work on the drive when it is energized, it will cause serious injury or death from electrical shock.*

1. Remove the keypad (B) and front cover (A).

Shut off power to the drive and wait for the time specified on the drive warning label at a minimum. Make sure that the charge indicator LED is unlit, then remove the keypad and front cover. Refer to the drive manuals for more information.

NOTICE *Damage to Equipment. When you touch the option, make sure that you observe correct electrostatic discharge (ESD) procedures. If you do not follow procedures, it can cause ESD damage to the drive circuitry.*

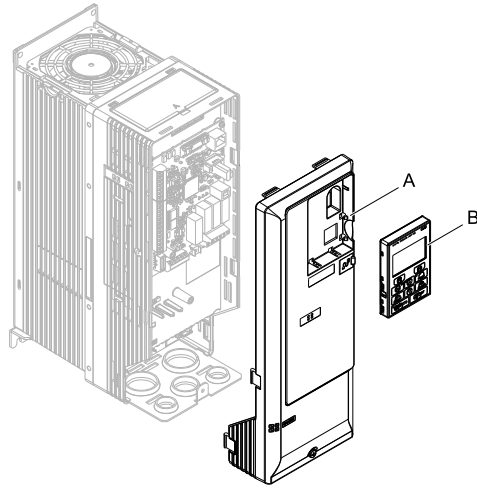

A - Drive front cover

B - Keypad

Figure 5.9 Remove the Front Cover and Keypad

- Put the LED label (B) in the correct position on the drive front cover (A).

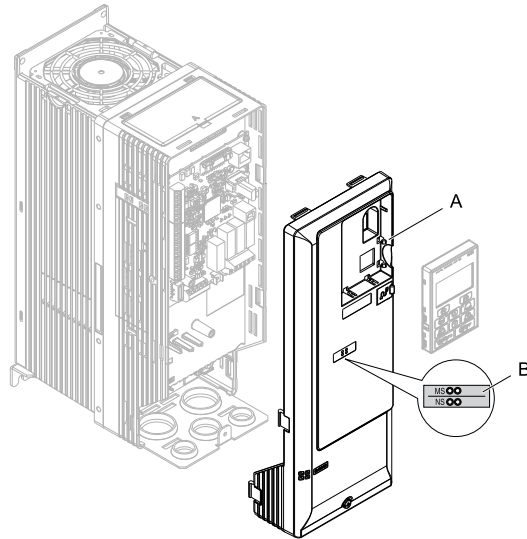

A - Drive front cover

B - LED label

Figure 5.10 Put the LED Label on the Drive Front Cover

3. Install the option (A) into the CN5 connector (C) on the drive and use one of the included screws (B) to put it in place.

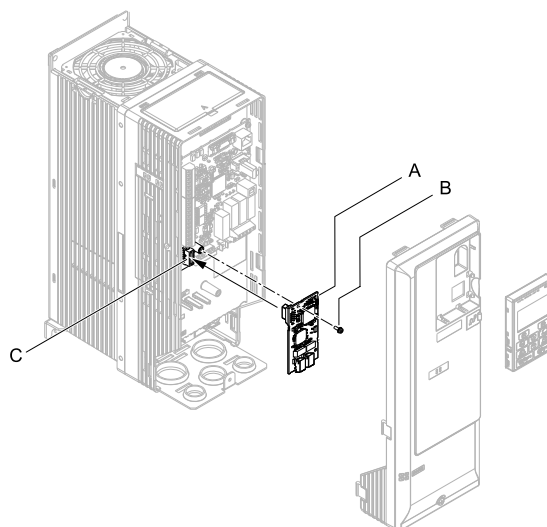

A - Option
B - Included screw

C - Connector CN5

Figure 5.11 Install the Option

4. Use one of the remaining included screws (B) to connect one end of the ground wire (C) to the ground terminal (A). Use the last remaining included screw (B) to connect the other end of the ground wire (C) to the remaining ground terminal and installation hole on the option (A).

Tighten the screws to a correct tightening torque:

- 0.5 N·m to 0.6 N·m (4.4 in·lb to 5.3 in·lb)

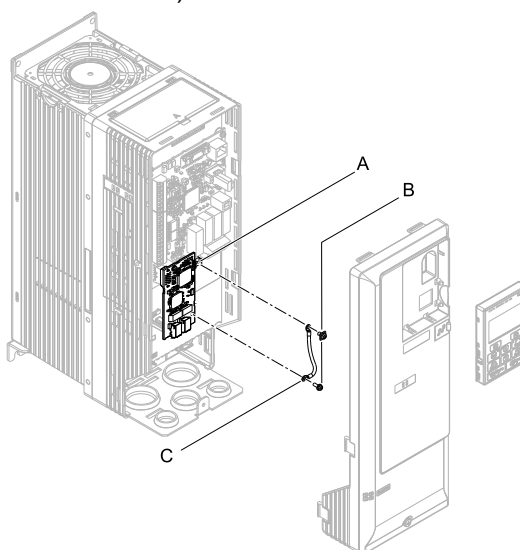

A - Drive grounding terminal (FE)
B - Included screws

C - Ground wire

Figure 5.12 Connect the Ground Wire

5. Firmly connect the Ethernet communication cable to the option modular connector CN1 port 1 or port 2. Isolate communication cables from main circuit wiring and other electrical and power lines. Make sure that you firmly connect the cable end. (Refer to [Figure 5.28](#)). Refer to [Communication Cable Specifications on page 30](#) for more information.

NOTICE *Damage to Equipment.* When you touch the option, make sure that you observe correct electrostatic discharge (ESD) procedures. If you do not follow procedures, it can cause ESD damage to the drive circuitry.

6. Reattach the drive front cover (A) and the keypad (B). Refer to the drive manuals for more information.

NOTICE *Do not pinch cables between the front covers and the drive. Failure to comply could cause erroneous operation.*

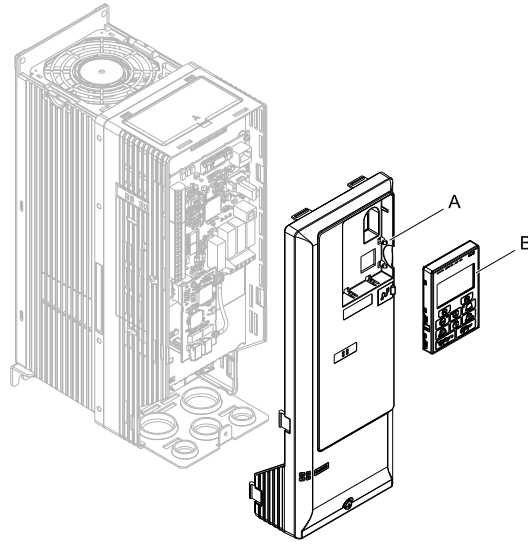

A - Drive front cover

B - Keypad

Figure 5.13 Replace the Front Cover and Keypad

7. Set drive parameters in [Related Drive Parameters on page 32](#) for correct option performance.

■ Procedure C

This section shows the procedure to install and wire the option on a GA700 or GA800 drive.

Prepare the Drive for the Option

Before you install the option on a YASKAWA AC Drive GA700 or GA800, make sure that the option software version is PRG: 0345 or later.

Correctly wire the drive as specified by the manual packaged with the drive. Make sure that the drive functions correctly. Refer to the drive manuals for more information.

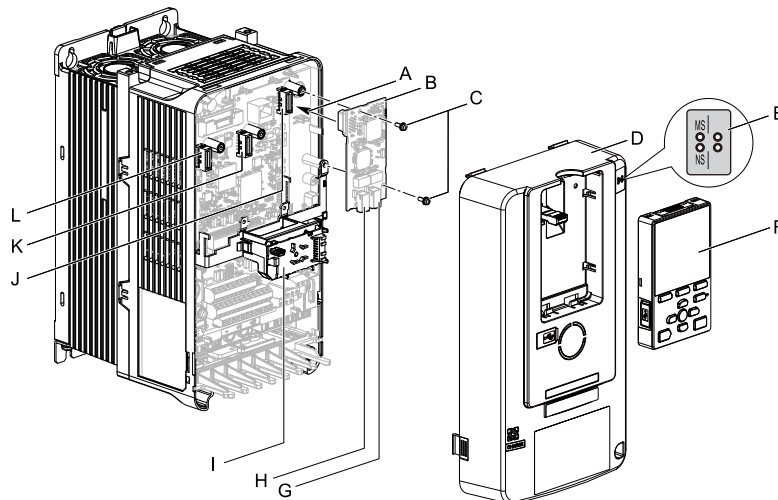

A - Insertion point for CN5 connector

B - Option

C - Included screws

D - Drive front cover

E - LED label

F - Keypad

G - Option modular connector CN1 port 1 (RJ45)

H - Option modular connector CN1 port 2 (RJ45)

I - LED Status Ring board

J - Connector CN5-A

K - Connector CN5-B (Not available for communication option installation.)

L - Connector CN5-C (Not available for communication option installation.)

Figure 5.14 Drive Components with Option

Install the Option

Use this procedure to install the option.

⚠ DANGER *Electrical Shock Hazard. Do not examine, connect, or disconnect wiring on an energized drive. Before servicing, disconnect all power to the equipment and wait for the time specified on the warning label at a minimum. The internal capacitor stays charged after the drive is de-energized. The charge indicator LED extinguishes when the DC bus voltage decreases below 50 Vdc. When all indicators are OFF, measure for dangerous voltages to make sure that the drive is safe. If you do work on the drive when it is energized, it will cause serious injury or death from electrical shock.*

1. Put the LED label (A) in the correct position on the drive front cover (B).

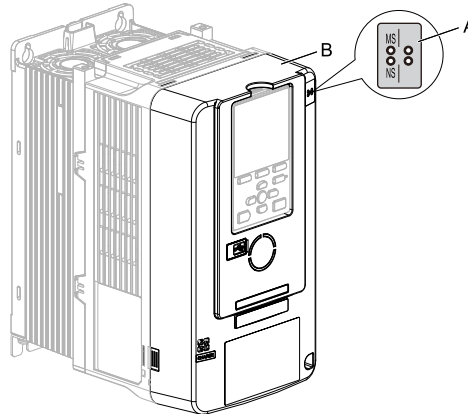

A - LED label

B - Drive front cover

Figure 5.15 Put the LED Label on the Drive Front Cover

2. Remove the keypad (E) and front cover (D).

Shut off power to the drive and wait for the time specified on the drive warning label at a minimum. Make sure that the charge indicator LED is unlit, then remove the keypad and front cover. Refer to the drive manuals for more information.

You can only install this option into the CN5-A connector on the drive control board.

NOTICE *Damage to Equipment. When you touch the option, make sure that you observe correct electrostatic discharge (ESD) procedures. If you do not follow procedures, it can cause ESD damage to the drive circuitry.*

Note:

Remove the keypad, then move the keypad connector to the holder on the drive, then remove the front cover.

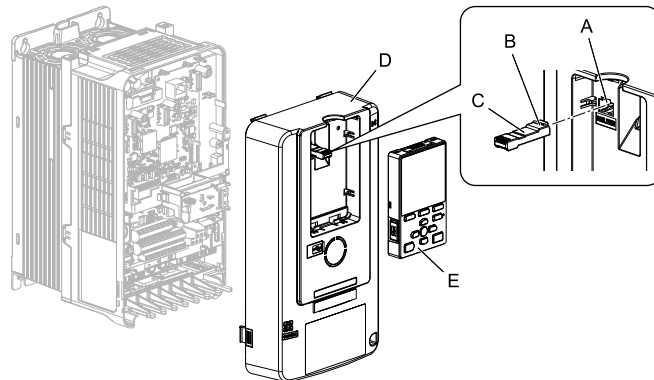

A - Holder

B - Keypad connector tab

C - Keypad connector

D - Drive front cover

E - Keypad

Figure 5.16 Remove the Front Cover and Keypad

3. Carefully remove the LED Status Ring board (A) and put it in the temporary placement holes (B) on the right side of the drive.

Refer to the drive manuals for more information.

NOTICE *Do not remove the LED Status Ring board cable connector. If you disconnect the LED Status Ring board, it can cause incorrect operation and damage to the drive.*

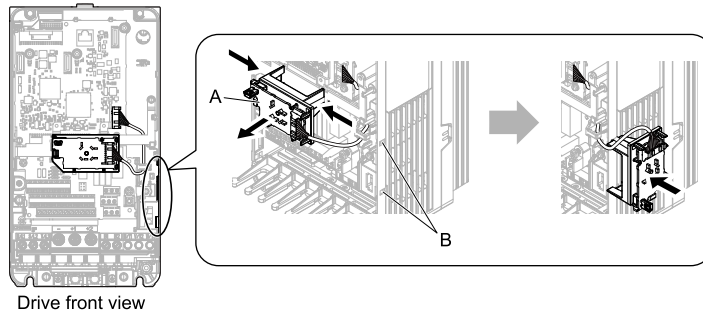

A - LED Status Ring board

B - Temporary placement holes

Figure 5.17 Remove the LED Status Ring Board

4. Install the option (A) into the CN5-A connector (C) on the drive and use the included screws (B) to put it in place.

Tighten the screws to a correct tightening torque:

- 0.5 N·m to 0.6 N·m (4.4 in·lb to 5.3 in·lb)

Note:

1. A ground wire is not necessary. Do not use the ground wire.
2. Only two screws are necessary to install the option on a GA700 and GA800 drive.
3. Three screws and one ground wire are packaged with option.

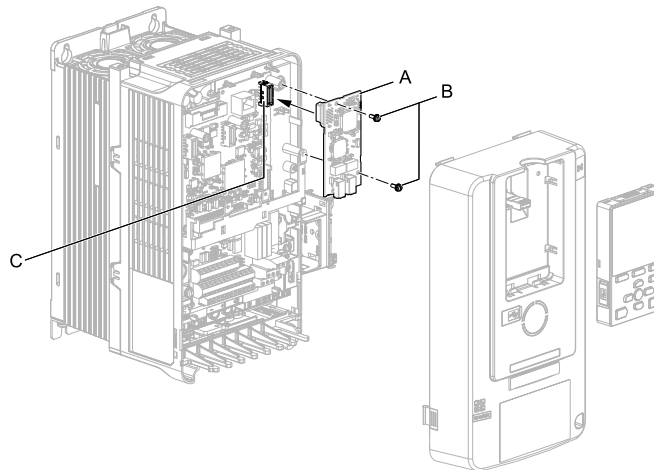

A - Option

B - Included screws

C - Connector CN5-A

Figure 5.18 Install the Option

5. Firmly connect the Ethernet communication cable to the option modular connector CN1 port 1 or port 2. Isolate communication cables from main circuit wiring and other electrical and power lines. Make sure that you firmly connect the cable end. (Refer to [Figure 5.28](#)). Refer to [Communication Cable Specifications on page 30](#) for more information.

NOTICE *Damage to Equipment.* When you touch the option, make sure that you observe correct electrostatic discharge (ESD) procedures. If you do not follow procedures, it can cause ESD damage to the drive circuitry.

6. Reattach the LED Status Ring board (E), front cover (C), and keypad (D). Refer to the drive manuals for more information.

NOTICE *Do not pinch cables between the front cover or the LED Status Ring board and the drive. Failure to comply could cause erroneous operation.*

Note:

- Replace the keypad connector then install the keypad.
- Put the keypad connector tab into the holder when you install the keypad connector to the holder.

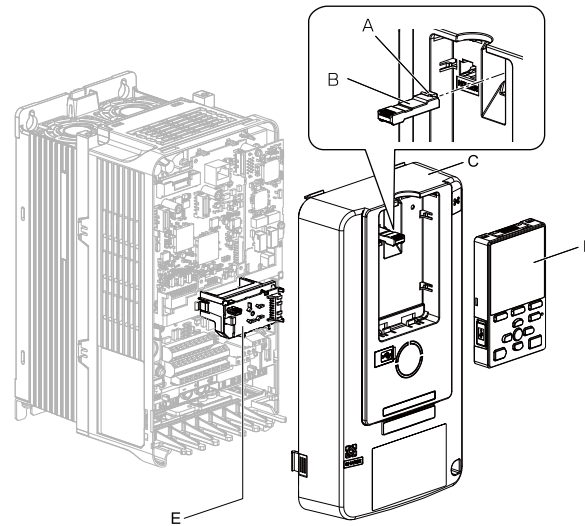

A - Keypad connector tab
 B - Keypad connector
 C - Drive front cover

D - Keypad
 E - LED Status Ring board

Figure 5.19 Install the LED Status Ring board, Front Cover, and Keypad

7. Set drive parameters in [Related Drive Parameters on page 32](#) for correct option performance.

■ Procedure D

This section shows the procedure to install and wire the option on an HV600 or FP605 drive.

Prepare the Drive for the Option

Before you install the option on an HV600 drive, make sure that the option software version is PRG: 0345 or later.

Before you install the option on an FP605 drive, make sure that the option software version is PRG: 0347 or later.

Correctly wire the drive as specified by the manual packaged with the drive. Make sure that the drive functions correctly. Refer to the drive manuals for more information.

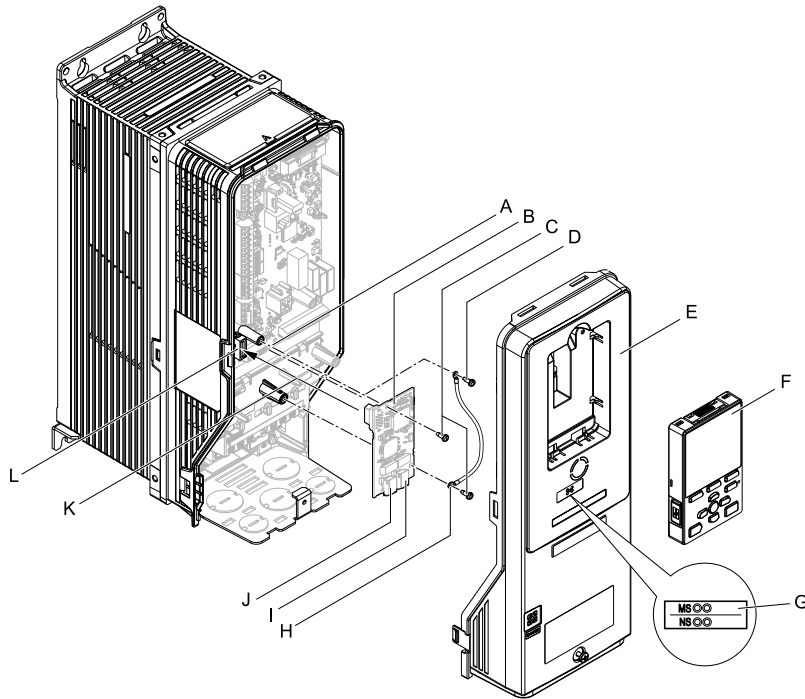

- | | |
|--|---|
| A - Drive grounding terminal (FE) | G - LED label |
| B - Option | H - Ground wire |
| C - Included screws | I - Option modular connector CN1 port 1 (RJ45) |
| D - Ground screw | J - Option modular connector CN1 port 2 (RJ45) |
| E - Drive front cover | K - Insertion point for connector (HV600: CN5, FP605: CN5-A) |
| F - Keypad | L - Connector (HV600: CN5, FP605: CN5-A) |

Figure 5.20 Drive Components with Option

Install the Option

Use this procedure to install the option.

⚠ DANGER *Electrical Shock Hazard. Do not examine, connect, or disconnect wiring on an energized drive. Before servicing, disconnect all power to the equipment and wait for the time specified on the warning label at a minimum. The internal capacitor stays charged after the drive is de-energized. The charge indicator LED extinguishes when the DC bus voltage decreases below 50 Vdc. When all indicators are OFF, measure for dangerous voltages to make sure that the drive is safe. If you do work on the drive when it is energized, it will cause serious injury or death from electrical shock.*

1. Remove the keypad (B) and front cover (A).

Shut off power to the drive and wait for the time specified on the drive warning label at a minimum. Make sure that the charge indicator LED is unlit, then remove the keypad and front cover. Refer to the drive manuals for more information.

NOTICE *Damage to Equipment. When you touch the option, make sure that you observe correct electrostatic discharge (ESD) procedures. If you do not follow procedures, it can cause ESD damage to the drive circuitry.*

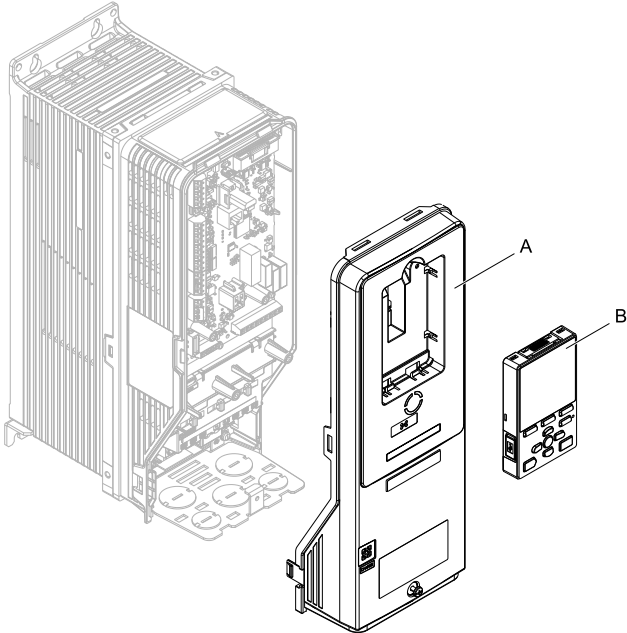

A - Drive front cover

B - Keypad

Figure 5.21 Remove the Front Cover and Keypad

- 2. Put the LED label (B) in the correct position on the drive front cover (A).

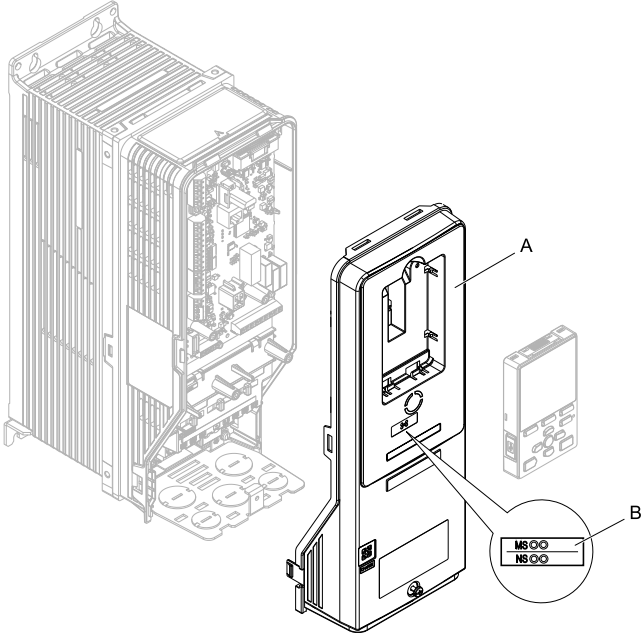

A - Drive front cover

B - LED label

Figure 5.22 Put the LED Label on the Drive Front Cover

- Remove the screw (B) installed in the drive grounding terminal (A).

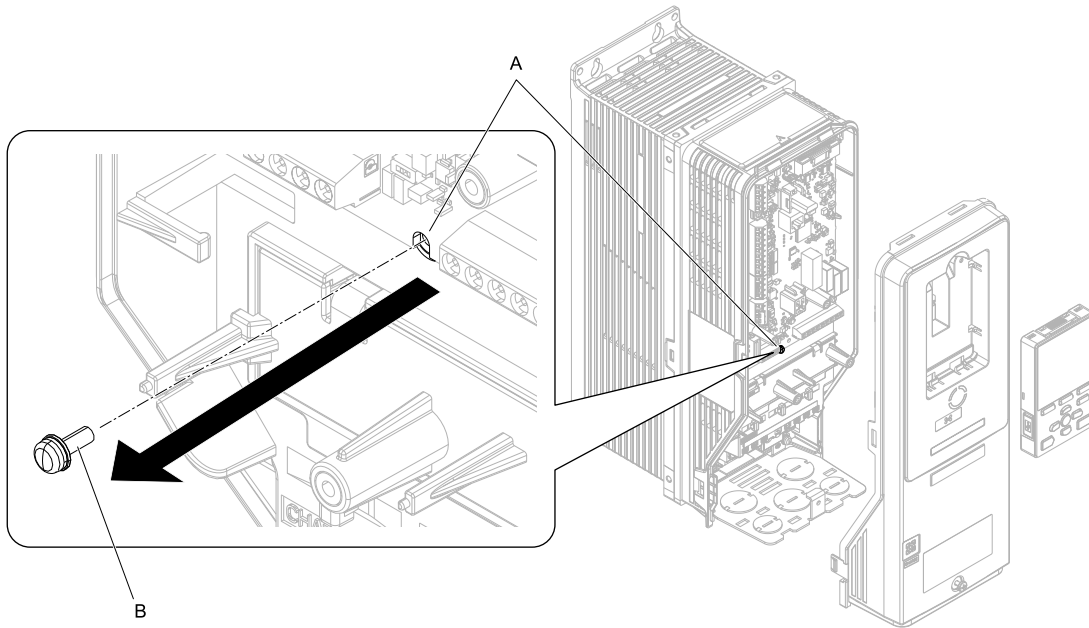

A - Drive grounding terminal (FE)

B - Ground screw

Figure 5.23 Remove the Screw from the Drive Grounding Terminal

- Use the screw (B) installed in the FE ground terminal of the drive (A) to connect one end of the included ground wire (C) to the ground terminal on the drive.
Tighten the screw to a correct tightening torque:
 - 0.5 N·m to 0.6 N·m (4.4 in·lb to 5.3 in·lb)

Note:

Route ground wire on the right side of the stud (D).

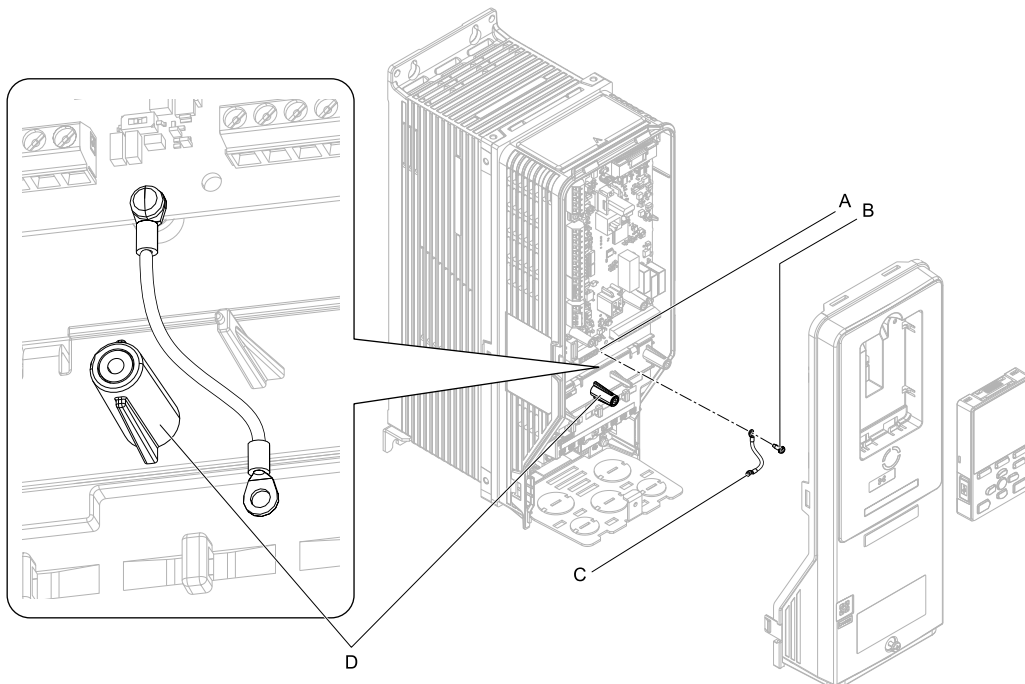

A - Drive grounding terminal (FE)

B - Ground screw

C - Ground wire

D - Stud

Figure 5.24 Connect the Ground Wire

- Install the option (A) into the connector (C) (HV600: CN5, FP605: CN5-A) on the drive and use the included screw (B) to put it in place.
Tighten the screw to a correct tightening torque:
 - 0.5 N·m to 0.6 N·m (4.4 in·lb to 5.3 in·lb)

Note:

Only two screws are necessary to install the option on HV600 and FP605 drives.

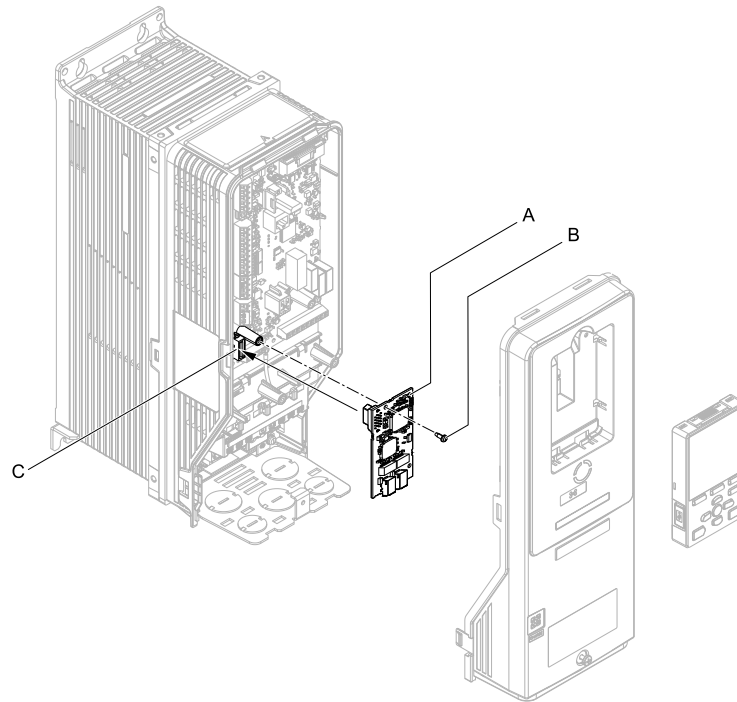

A - Option
B - Included screw

C - Connector CN5

Figure 5.25 Install the Option

- Use one of the remaining included screws (B) to connect the ground wire (A) to the ground terminal and installation hole on the option.

Tighten the screw to a correct tightening torque:

- 0.5 N·m to 0.6 N·m (4.4 in·lb to 5.3 in·lb)

Note:

Refer to [Figure 5.26](#) for instruction about crimp terminal orientation (C) and wire routing.

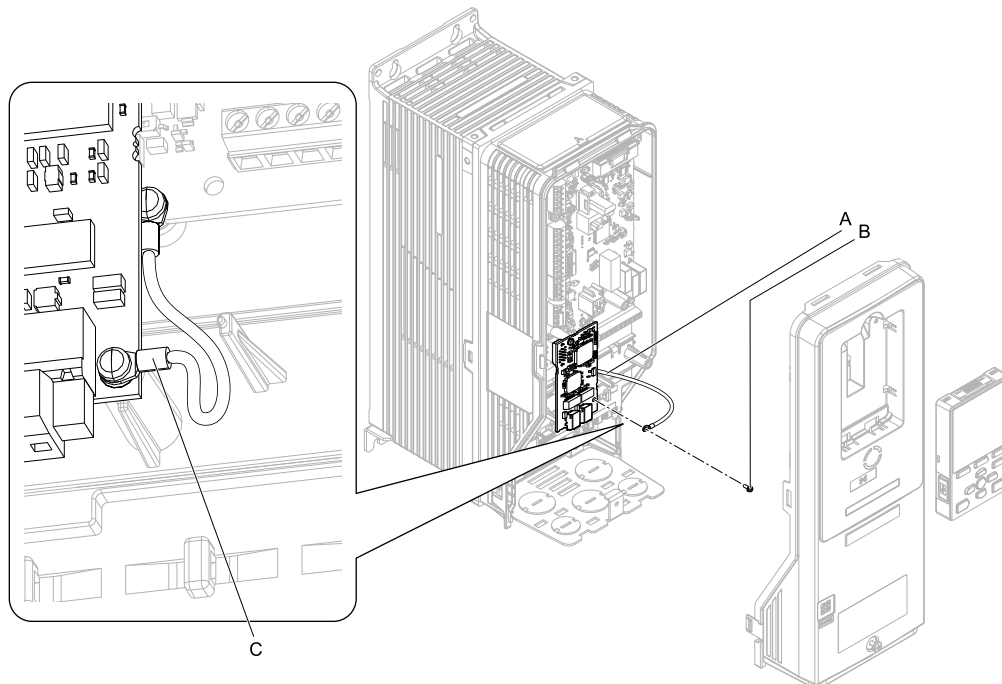

A - Ground wire
B - Included screw

C - Crimp terminal

Figure 5.26 Connect the Ground Wire

7. Firmly connect the Ethernet communication cable to the option modular connector CN1 port 1 or port 2. Isolate communication cables from main circuit wiring and other electrical and power lines. Make sure that you firmly connect the cable end. (Refer to [Figure 5.28](#)). Refer to [Communication Cable Specifications on page 30](#) for more information.

NOTICE *Damage to Equipment.* When you touch the option, make sure that you observe correct electrostatic discharge (ESD) procedures. If you do not follow procedures, it can cause ESD damage to the drive circuitry.

8. Reattach the drive front cover (A) and the keypad (B).
Refer to the drive manuals for more information.

NOTICE *Do not pinch cables between the front covers and the drive. Failure to comply could cause erroneous operation.*

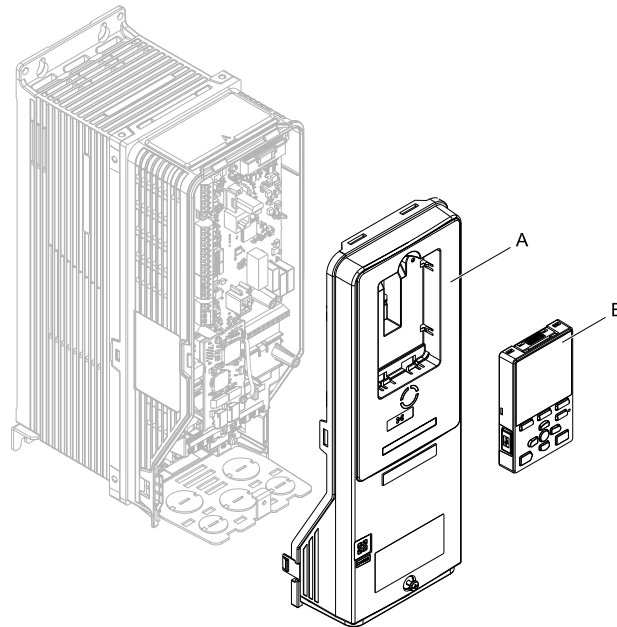

A - Drive front cover

B - Keypad

Figure 5.27 Replace the Front Cover and Keypad

9. Set drive parameters in [Related Drive Parameters on page 32](#) for correct option performance.

◆ IGMP Snooping

Switches implementing IGMP Snooping are strongly recommended. When IGMP Snooping is used, devices will only receive the multicast packets in which they are interested.

◆ Communication Cable Specifications

Yaskawa recommends using shielded Cat5e cable. The Yaskawa warranty does not cover other cable types.

6 Related Drive Parameters

These parameters set the drive for operation with the option. Make sure that the parameter settings in this table are correct before you start network communications.

Note:

Hex.: MEMOBUS addresses that you can use to change parameters over network communication are represented in hexadecimal numbers.

No. (Hex.)	Name	Description	Default (Range)
b1-01 (0180)	Frequency Reference Selection 1	<p>Selects the input method for frequency reference.</p> <p>0 : Keypad 1 : Analog Input 2 : Memobus/Modbus Communications 3 : Option PCB 4 : Pulse Train Input</p> <p>Note:</p> <ul style="list-style-type: none"> Set <i>b1-02</i> = 3 [<i>Run Command Selection 1 = Option PCB</i>] to use the master device and serial communications to start and stop the drive. Set <i>b1-01</i> = 3 to use the master device to control the frequency reference of the drive. The default setting is different for different drives. Refer to the instruction manual of your specific drive for more information. 	1 (0 - 4)
b1-02 (0181)	Run Command Selection 1	<p>Selects the input method for the Run command.</p> <p>0 : Keypad 1 : Digital Input 2 : Memobus/Modbus Communications 3 : Option PCB 7 : AUTO Command + Term Run 8 : AUTO Command + Serial Run 9 : AUTO Command + Option Run</p> <p>Note:</p> <ul style="list-style-type: none"> Set <i>b1-02</i> = 3 to start and stop the drive with the master device using serial communications. Set <i>b1-01</i> = 3 [<i>Frequency Reference Selection 1 = Option PCB</i>] to use the master device to control the frequency reference of the drive. Settings 7 to 9 are available in HV600 software versions PRG: 1011 and later. 	1 (0 - 9)
F6-01 (03A2)	Communication Error Selection	<p>Selects drive response when the drive detects a <i>bUS</i> [<i>Option Communication Error</i>] error during communications with the option.</p> <p>0 : Ramp to Stop 1 : Coast to Stop 2 : Fast Stop (Use C1-09) 3 : Alarm Only 4 : Alarm (Run at <i>d1-04</i>) 5 : Alarm - Ramp Stop</p> <p>Note:</p> <ul style="list-style-type: none"> When you set this parameter to 3 or 4, the drive will continue operation after it detects a fault. Separately prepare safety protection equipment and systems, for example fast-stop switches. Refer to the drive manual to know if settings 4 and 5 are available. The setting range for 1000-Series drives is different for different software versions. Refer to the Peripheral Devices & Options section of the drive instruction manual for more information. Changes to this parameter take effect immediately. It is not necessary to cycle power on the drive. 	1 (0 - 5)
F6-02 (03A3)	Comm External Fault (EF0) Detect	<p>Selects the conditions at which <i>EF0</i> [<i>Option Card External Fault</i>] is detected.</p> <p>0 : Always Detected 1 : Detected during RUN Only</p>	0 (0, 1)
F6-03 (03A4)	Comm External Fault (EF0) Select	<p>Selects the operation of the drive when <i>EF0</i> [<i>Option Card External Fault</i>] is detected.</p> <p>0 : Ramp to Stop 1 : Coast to Stop 2 : Fast Stop (Use C1-09) 3 : Alarm Only</p> <p>Note:</p> <p>When you set this parameter to 3, the drive will continue operation after it detects a fault. Separately prepare safety protection equipment and systems, for example fast stop switches.</p>	1 (0 - 3)
F6-06 (03A7)	Torque Reference/Limit by Comm	<p>Sets the function that enables and disables the torque reference and torque limit received from the communication option.</p> <p>0 : Disabled 1 : Enabled</p> <p>Note:</p> <ul style="list-style-type: none"> Control method availability of this parameter is different for different product series. <ul style="list-style-type: none"> 1000-Series Parameter is available in <i>A1-02</i> = 3, 6, 7 [<i>Control Method Selection = Closed Loop Vector, PM Advanced Open Loop Vector, PM Closed Loop Vector</i>]. When you enable this parameter, <i>d5-01</i> [<i>Torque Control Selection</i>] sets the drive to read the value as the Torque Limit value or the Torque Reference value. <ul style="list-style-type: none"> <i>d5-01</i> = 0 [<i>Speed Control</i>]: Torque Limit 	0 (0, 1)

No. (Hex.)	Name	Description	Default (Range)
		<p><i>d5-01 = 1 [Torque Control]</i>: Torque Reference In <i>A1-02 = 6 [Control Method Selection = PM Advanced Open Loop Vector]</i>, this value is read as the Torque Limit.</p> <p>–GA500 Parameter is available in <i>A1-02 = 2, 6, 8 [Control Method Selection = Open Loop Vector; PM Advanced Open Loop Vector; EZ Vector Control]</i>. The drive reads this value as the Torque Limit.</p> <p>–GA700, GA800 Parameter is available when <i>A1-02 = 2, 3, 4, 6, 7, 8 [Control Method Selection = Open Loop Vector; Closed Loop Vector; Advanced Open Loop Vector; PM Advanced Open Loop Vector; PM Closed Loop Vector; EZ Vector Control]</i>. When you enable this parameter, <i>d5-01 [Torque Control Selection]</i> sets the drive to read the value as the Torque Limit value or the Torque Reference value.</p> <p><i>d5-01 = 0 [Speed Control]</i>: Torque Limit <i>d5-01 = 1 [Torque Control]</i>: Torque Reference When <i>A1-02 = 2, 8 [Control Method Selection = Open Loop Vector; EZ Vector Control]</i>, this value is read as the Torque Limit.</p> <p>–HV600, FP605 Torque Limit is enabled when <i>A1-02 = 8 [Control Method Selection = EZ Vector Control]</i>.</p> <ul style="list-style-type: none"> If the PLC does not supply a torque reference or torque limit when <i>F6-06 = 1 [Torque Reference/Limit by Comm = Enabled]</i>, the motor cannot rotate. 	
F6-07 (03A8)	Multi-Step Ref @ NetRef/ComRef	<p>0 : Disable Multi-Step References 1 : Enable Multi-Step References</p> <p>Note: Default setting of <i>F6-07</i> is 1 for GA500.</p>	0 (0, 1)
F6-08 (036A)	Comm Parameter Reset @Initialize	<p>Selects whether communication-related parameters <i>F6-xx</i> and <i>F7-xx</i> are set back to original default values when you use parameter <i>A1-03 [Initialize Parameters]</i> to initialize the drive.</p> <p>0 : No Reset - Parameters Retained 1 : Reset - Back to Factory Default</p> <p>Note: When you set <i>F6-08</i> to 1 and you then use <i>A1-03</i> to initialize the drive, the drive will not change this setting value.</p>	0 (0, 1)
F6-14 (03BB)	Bus Error Auto Reset	<p>Enables and disables the automatic reset of a <i>bUS [Option Communication Error]</i> fault.</p> <p>0 : Disabled 1 : Enabled</p> <p>Note:</p> <ul style="list-style-type: none"> This parameter is not available in all 1000-series drives. Changes to this parameter take effect immediately. It is not necessary to cycle power on the drive. 	0 (0, 1)
F6-15 (0B5B)	Comm. Option Parameters Reload	<p>Sets how the drive will enable the <i>F6-xx/F7-xx</i> communication-related parameters that you changed.</p> <p>0 : Reload at Next Power Cycle 1 : Reload Now 2 : Cancel Reload Request</p> <p>Note:</p> <ul style="list-style-type: none"> <i>F6-15</i> is reset to 0 after setting 1 or 2. Available in option software versions PRG: 0345 and later. Not available on 1000-series drives. 	0 (0 - 2)
F7-01 (03E5)	IP Address 1	<p>Sets the static/fixed IP address. Sets the most significant octet.</p> <p>Note:</p> <ul style="list-style-type: none"> This parameter is only effective when <i>F7-13 = 0 [Address Mode at Startup = Static]</i>. All IP Addresses must be unique. You must cycle power to the drive for the changes to take effect. For non-1000 series drives, you can set <i>F6-15 = 1 [Comm. Option Parameters Reload = Reload Now]</i>. 	192 (0 - 255)
F7-02 (03E6)	IP Address 2	<p>Sets the static/fixed IP address. Sets the second most significant octet.</p> <p>Note:</p> <ul style="list-style-type: none"> This parameter is only effective when <i>F7-13 = 0 [Address Mode at Startup = Static]</i>. All IP Addresses must be unique. You must cycle power to the drive for the changes to take effect. For non-1000 series drives, you can set <i>F6-15 = 1 [Comm. Option Parameters Reload = Reload Now]</i>. 	168 (0 - 255)
F7-03 (03E7)	IP Address 3	<p>Sets the static/fixed IP address. Sets the third most significant octet.</p> <p>Note:</p> <ul style="list-style-type: none"> This parameter is only effective when <i>F7-13 = 0 [Address Mode at Startup = Static]</i>. All IP Addresses must be unique. You must cycle power to the drive for the changes to take effect. For non-1000 series drives, you can set <i>F6-15 = 1 [Comm. Option Parameters Reload = Reload Now]</i>. 	1 (0 - 255)
F7-04 (03E8)	IP Address 4	<p>Sets the static/fixed IP address. Sets the fourth most significant octet.</p> <p>Note:</p> <ul style="list-style-type: none"> This parameter is only effective when <i>F7-13 = 0 [Address Mode at Startup = Static]</i>. All IP Addresses must be unique. You must cycle power to the drive for the changes to take effect. For non-1000 series drives, you can set <i>F6-15 = 1 [Comm. Option Parameters Reload = Reload Now]</i>. 	20 (0 - 255)
F7-05 (03E9)	Subnet Mask 1	<p>Sets the static/fixed Subnet Mask. Sets the most significant octet.</p> <p>Note:</p> <ul style="list-style-type: none"> This parameter is only effective when <i>F7-13 = 0 [Address Mode at Startup = Static]</i>. All IP Addresses must be unique. 	255 (0 - 255)

6 Related Drive Parameters

No. (Hex.)	Name	Description	Default (Range)
		<ul style="list-style-type: none"> You must cycle power to the drive for the changes to take effect. For non-1000 series drives, you can set $F6-15 = 1$ [Comm. Option Parameters Reload = Reload Now]. 	
F7-06 (03EA)	Subnet Mask 2	Sets the static/fixed Subnet Mask. Sets the second most significant octet. Note: <ul style="list-style-type: none"> This parameter is only effective when $F7-13 = 0$ [Address Mode at Startup = Static]. All IP Addresses must be unique. You must cycle power to the drive for the changes to take effect. For non-1000 series drives, you can set $F6-15 = 1$ [Comm. Option Parameters Reload = Reload Now]. 	255 (0 - 255)
F7-07 (03EB)	Subnet Mask 3	Sets the static/fixed Subnet Mask. Sets the third most significant octet. Note: <ul style="list-style-type: none"> This parameter is only effective when $F7-13 = 0$ [Address Mode at Startup = Static]. All IP Addresses must be unique. You must cycle power to the drive for the changes to take effect. For non-1000 series drives, you can set $F6-15 = 1$ [Comm. Option Parameters Reload = Reload Now]. 	255 (0 - 255)
F7-08 (03EC)	Subnet Mask 4	Sets the static/fixed Subnet Mask. Parameter F7-08 sets the fourth most significant octet. Note: <ul style="list-style-type: none"> This parameter is only effective when $F7-13 = 0$ [Address Mode at Startup = Static]. All IP Addresses must be unique. You must cycle power to the drive for the changes to take effect. For non-1000 series drives, you can set $F6-15 = 1$ [Comm. Option Parameters Reload = Reload Now]. 	0 (0 - 255)
F7-09 (03ED)	Gateway Address 1	Sets the static/fixed Gateway address. Sets the most significant octet. Note: <ul style="list-style-type: none"> This parameter is only effective when $F7-13 = 0$ [Address Mode at Startup = Static]. All IP Addresses must be unique. You must cycle power to the drive for the changes to take effect. For non-1000 series drives, you can set $F6-15 = 1$ [Comm. Option Parameters Reload = Reload Now]. 	192 (0 - 255)
F7-10 (03EE)	Gateway Address 2	Sets the static/fixed Gateway address. Sets the second most significant octet. Note: <ul style="list-style-type: none"> This parameter is only effective when $F7-13 = 0$ [Address Mode at Startup = Static]. All IP Addresses must be unique. You must cycle power to the drive for the changes to take effect. For non-1000 series drives, you can set $F6-15 = 1$ [Comm. Option Parameters Reload = Reload Now]. 	168 (0 - 255)
F7-11 (03EF)	Gateway Address 3	Sets the static/fixed Gateway address. Sets the third most significant octet. Note: <ul style="list-style-type: none"> This parameter is only effective when $F7-13 = 0$ [Address Mode at Startup = Static]. All IP Addresses must be unique. You must cycle power to the drive for the changes to take effect. For non-1000 series drives, you can set $F6-15 = 1$ [Comm. Option Parameters Reload = Reload Now]. 	1 (0 - 255)
F7-12 (03F0)	Gateway Address 4	Sets the static/fixed Gateway address. Parameter F7-12 sets the fourth most significant octet. Note: <ul style="list-style-type: none"> This parameter is only effective when $F7-13 = 0$ [Address Mode at Startup = Static]. All IP Addresses must be unique. You must cycle power to the drive for the changes to take effect. For non-1000 series drives, you can set $F6-15 = 1$ [Comm. Option Parameters Reload = Reload Now]. 	1 (0 - 255)
F7-13 (03F1)	Address Startup Mode	Selects how the option address is set. 0 : Static (Use F7-01 to F7-12 to set.) 1 : BOOTP (Use network address.) 2 : DHCP (Use network address.) Note: You must cycle power to the drive for the changes to take effect. For non-1000 series drives, you can set $F6-15 = 1$ [Comm. Option Parameters Reload = Reload Now].	2 (0 - 2)
F7-14 (03F2)	Duplex Mode Selection	Selects duplex mode setting (Port 1/Port 2). 0 : Half/Half 1 : Auto/Auto 2 : Full/Full 3 : Half/Auto 4 : Half/Full 5 : Auto/Half 6 : Auto/Full 7 : Full/Half 8 : Full/Auto Note: <ul style="list-style-type: none"> When you set this parameter to 0, 2, 3, 4, 7, or 8, you must also set $F7-15 = 0.0$. This option sets the duplex mode for port 1 and port 2 as specified by these F7-14. <ul style="list-style-type: none"> –When 0: Half/Half, port 1/port 2 is set to Half. –When 1: Auto/Auto, port 1/port 2 is set to Auto. –When 2: Full/Full, port 1/port 2 is set to Full. –When 3: Half/Auto, port 1 is set to Half and port 2 is set to Auto. –When 4: Half/Full, port 1 is set to Half and port 2 is set to Full. –When 5: Auto/Half, port 1 is set to Auto and port 2 is set to Half. –When 6: Auto/Full, port 1 is set to Auto and port 2 is set to Full. –When 7: Full/Half, port 1 is set to Full and port 2 is set to Half. 	1 (0 - 8)

No. (Hex.)	Name	Description	Default (Range)
		–When 8: Full/Auto, port 1 is set to Full and port 2 is set to Auto.	
F7-15 (03F3)	Communication Speed Selection	Sets the communications speed (Port 1/Port 2). 10 : 10/10 Mbps 100 : 100/100 Mbps 101 : 10/100 Mbps 102 : 100/10 Mbps Note: F7-15 is only effective when the port is set to half or full duplex in F7-14 [Duplex Mode Selection].	10 (10 - 102)
F7-16 (03F4)	Timeout Value	Sets the detection time for a communications timeout. Note: • Set this parameter to 0.0 to disable the connection timeout function. • This parameter is not available in all 1000-series drives. • Changes to this parameter take effect immediately. It is not necessary to cycle power on the drive.	0.0 s (0.0 s - 30.0 s)
F7-17 (03F5)	EtherNet/IP Speed Scaling Factor	Sets the scaling factor for the speed monitor in EtherNet/IP Class ID 2A (Hex.) Object. Note: Changes to this parameter take effect immediately. It is not necessary to cycle power on the drive.	0 (-15 - 15)
F7-18 (03F6)	EtherNet/IP Current Scale Factor	Sets the scaling factor for the output current monitor in EtherNet/IP Class ID 2A (Hex.) Object. Note: Changes to this parameter take effect immediately. It is not necessary to cycle power on the drive.	0 (-15 - 15)
F7-19 (03F7)	EtherNet/IP Torque Scale Factor	Sets the scaling factor for the torque monitor in EtherNet/IP Class ID 2A (Hex.) Object. Note: Changes to this parameter take effect immediately. It is not necessary to cycle power on the drive.	0 (-15 - 15)
F7-20 (03F8)	EtherNet/IP Power Scaling Factor	Sets the scaling factor for the power monitor in EtherNet/IP Class ID 2A (Hex.) Object. Note: Changes to this parameter take effect immediately. It is not necessary to cycle power on the drive.	0 (-15 - 15)
F7-21 (03F9)	EtherNet/IP Voltage Scale Factor	Sets the scaling factor for the voltage monitor in EtherNet/IP Class ID 2A (Hex.) Object. Note: Changes to this parameter take effect immediately. It is not necessary to cycle power on the drive.	0 (-15 - 15)
F7-22 (03FA)	EtherNet/IP Time Scaling	Sets the scaling factor for the time monitor in EtherNet/IP Class ID 2A (Hex.) Object. Note: Changes to this parameter take effect immediately. It is not necessary to cycle power on the drive.	0 (-15 - 15)
F7-23 - F7-27 (03FB - 03FF) F7-28 - F7-32 (0370 - 0374)	Dynamic Output Assembly Parameters 1 to 10	Parameters used in Output Assemblies 116, 117, 118, 119, 120. Each parameter contains a MEMOBUS/Modbus address. The value received for the Output Assembly will be written to this corresponding MEMOBUS/Modbus address. A MEMOBUS/Modbus address value of 0 means that the value received for the Output Assembly will not be written to any MEMOBUS/Modbus register.	0 (-)
F7-33 - F7-42 (0375 to 037E)	Dynamic Input Assembly Parameters 1 to 10	Parameters used in Input Assemblies 166, 167, 168, 169, 170. Each parameter contains a MEMOBUS/Modbus address. The value sent for the Input Assembly will be read from this corresponding MEMOBUS/Modbus address. A MEMOBUS/Modbus address value of 0 means that the value sent for the Input Assembly is not defined by the user, therefore the option default register value will be returned.	0 (-)

Table 6.1 Option Monitor

No.	Name	Description	Range
U6-80 - U6-83	Option IP Address 1 - 4	Shows the currently available local IP Address. • U6-80: First octet • U6-81: Second octet • U6-82: Third octet • U6-83: Forth octet	0 - 255
U6-84 - U6-87	Online Subnet 1 - 4	Shows the currently available subnet mask. • U6-84: First octet • U6-85: Second octet • U6-86: Third octet • U6-87: Forth octet	0 - 255
U6-88 - U6-91	Online Gateway 1 - 4	Shows the currently available gateway address. • U6-88: First octet • U6-89: Second octet • U6-90: Third octet • U6-91: Forth octet	0 - 255
U6-92	Online Speed	Shows CN1 Port 1 link speed currently available.	10: 10 Mbps 100: 100 Mbps

6 Related Drive Parameters

No.	Name	Description	Range
U6-93	Online Duplex	Shows CN1 Port 1 duplex setting currently available.	0: Half/Half 1: Full/Full
U6-94	OPT SPARE 1	Shows CN1 Port 2 link speed currently available.	10: 10 Mbps 100: 100 Mbps
U6-95	OPT SPARE 2	Shows CN1 Port 2 duplex setting currently available.	0: Half/Half 1: Full/Full
U6-97	OPT SPARE 4	Shows option software version.	-
U6-98	First Fault	Shows first option fault. Refer to page 119 for more information.	-
U6-99	Current Fault	Shows current option fault. Refer to page 119 for more information.	-

7 EtherNet/IP Configuring Messaging

This section provides information on methods used to control the drive and converter with the option installed.

◆ Drive Polled Configuration

The assemblies in [Table 7.1](#) are available for polled I/O:

Note:

These assemblies are not available in D1000 and R1000.

Table 7.1 Supported Polled I/O Assemblies

Assembly Number (Hex.)	Description	Type	Bytes	Page
20 (14)	EtherNet/IP Basic Speed Control Output	Output	4	38
21 (15)	EtherNet/IP Extended Speed Control Output	Output	4	38
22 (16)	EtherNet/IP Speed and Torque Control Output	Output	6	39
23 (17)	EtherNet/IP Extended Speed and Torque Control Output	Output	6	40
70 (46)	EtherNet/IP Basic Speed Control Input	Input	4	51
71 (47)	EtherNet/IP Extended Speed Control Input	Input	4	51
72 (48)	EtherNet/IP Speed and Torque Control Input	Input	6	52
73 (49)	EtherNet/IP Extended Speed and Torque Control Input	Input	6	52
100 (64)	(Vendor Specific Yaskawa Electric (YE) Assy) MEMOBUS Message Output	Output	5	40
101 (65)	(Vendor Specific Yaskawa Electric (YE) Assy) Speed/Torque Control Output	Output	8	41
115 (73)	(Vendor Specific Yaskawa Electric (YE) Assy) Extended Speed/Torque Control Output	Output	40	42
116 (74)	(Vendor Specific Yaskawa Electric (YE) Assy) High Speed/Torque Control Output	Output	44	44
117 (75)	(Vendor Specific Yaskawa Electric (YE) Assy) 8-Byte Dynamic Output	Output	8	46
118 (76)	(Vendor Specific Yaskawa Electric (YE) Assy) 12-Byte Dynamic Output	Output	12	47
119 (77)	(Vendor Specific Yaskawa Electric (YE) Assy) 18-Byte Dynamic Output	Output	18	48
120 (78)	(Vendor Specific Yaskawa Electric (YE) Assy) 24-Byte Dynamic Output	Output	24	49
150 (96)	(Vendor Specific Yaskawa Electric (YE) Assy) MEMOBUS Message Input	Input	5	53
151 (97)	(Vendor Specific Yaskawa Electric (YE) Assy) Speed/Torque Status Input	Input	8	54
155 (9B)	(Vendor Specific Yaskawa Electric (YE) Assy) Extended Speed/ Torque Status Input	Input	40	55
166 (A6)	(Vendor Specific Yaskawa Electric (YE) Assy) High Speed/Torque Status Input	Input	44	58
167 (A7)	(Vendor Specific Yaskawa Electric (YE) Assy) 8-Byte Dynamic Input	Input	8	61
168 (A8)	(Vendor Specific Yaskawa Electric (YE) Assy) 12-Byte Dynamic Input	Input	12	62
169 (A9)	(Vendor Specific Yaskawa Electric (YE) Assy) 18-Byte Dynamic Input	Input	18	63
170 (AA)	(Vendor Specific Yaskawa Electric (YE) Assy) 24-Byte Dynamic Input	Input	24	65

◆ Converter Polled Configuration

The assemblies in [Table 7.2](#) are available for polled I/O:

Note:

These assemblies apply to D1000/R1000 converters.

Table 7.2 Supported Polled I/O Assemblies

Assembly Number (Hex.)	Description	Type	Bytes	Page
20 (14)	EtherNet/IP Basic Speed Control Output	Output	4	66
21 (15)	EtherNet/IP Extended Speed Control Output	Output	4	67
22 (16)	EtherNet/IP Speed and Torque Control Output	Output	6	68
23 (17)	EtherNet/IP Extended Speed and Torque Control Output	Output	6	68

8 Output Assemblies (Drive Consumes)

Assembly Number (Hex.)	Description	Type	Bytes	Page
70 (46)	EtherNet/IP Basic Speed Control Input	Input	4	79
71 (47)	EtherNet/IP Extended Speed Control Input	Input	4	79
72 (48)	EtherNet/IP Speed and Torque Control Input	Input	6	80
73 (49)	EtherNet/IP Extended Speed and Torque Control Input	Input	6	80
101 (65)	(Vendor Specific Yaskawa Electric (YE) Assy) Speed/Torque Control Output	Output	8	69
115 (73)	(Vendor Specific Yaskawa Electric (YE) Assy) Extended Speed/Torque Control Output	Output	40	70
116 (74)	(Vendor Specific Yaskawa Electric (YE) Assy) High Speed/Torque Control Output	Output	44	71
117 (75)	(Vendor Specific Yaskawa Electric (YE) Assy) 8-Byte Dynamic Output 2	Output	8	74
118 (76)	(Vendor Specific Yaskawa Electric (YE) Assy) 12-Byte Dynamic Output 4	Output	12	75
119 (77)	(Vendor Specific Yaskawa Electric (YE) Assy) 18-Byte Dynamic Output 7	Output	18	76
120 (78)	(Vendor Specific Yaskawa Electric (YE) Assy) 24-Byte Dynamic Output 10	Output	24	77
151 (97)	(Vendor Specific Yaskawa Electric (YE) Assy) Speed/Torque Status Input	Input	8	81
155 (9B)	(Vendor Specific Yaskawa Electric (YE) Assy) Extended Speed/Torque Status Input	Input	40	82
166 (A6)	(Vendor Specific Yaskawa Electric (YE) Assy) High Speed/Torque Status Input	Input	44	84
167 (A7)	(Vendor Specific Yaskawa Electric (YE) Assy) 8-Byte Dynamic Input 2	Input	8	87
168 (A8)	(Vendor Specific Yaskawa Electric (YE) Assy) 12-Byte Dynamic Input 4	Input	12	88
169 (A9)	(Vendor Specific Yaskawa Electric (YE) Assy) 18-Byte Dynamic Input 7	Input	18	90
170 (AA)	(Vendor Specific Yaskawa Electric (YE) Assy) 24-Byte Dynamic Input 10	Input	24	91

8 Output Assemblies (Drive Consumes)

Note:

The convention in this manual is from the PLC perspective. As such, an assembly is called an "Output Assembly" when outputted from the PLC and received by this node. This section details "Output Assemblies" that are "Consumed" by the drive.

◆ EtherNet/IP Basic Speed Control Output - 20 (0x14)

Output Instance	Word	Byte	Bit 7	Bit 6	Bit 5	Bit 4	Bit 3	Bit 2	Bit 1	Bit 0	
20	0	0	-	-	-	-	-	Fault Reset	-	Run Fwd	
		1	-								
	1	2	Speed Reference (Low Byte)								
		3	Speed Reference (High Byte)								

Name	Description
Run Fwd	Forward Run Command 0: Stop 1: Forward Run
Fault Reset	Fault Reset 0: - 1: Fault Reset
Speed Reference	Speed Command Sets drive speed reference. Speed reference data: Frequency reference/2 ^{SS} (SS: Speed scale) Setting range: 0 - FFFF (Hex.) For example, when setting a reference of 4096 with a speed scale of 2: Speed reference data = 4096/2 ² = 1024 = 400 (Hex.) Unit depends on o1-03.

◆ EtherNet/IP Extended Speed Control Output - 21 (0x15)

Output Instance	Word	Byte	Bit 7	Bit 6	Bit 5	Bit 4	Bit 3	Bit 2	Bit 1	Bit 0
21	0	0	-	NetRef	NetCtrl	-	-	Fault Reset	Run Rev	Run Fwd

Output Instance	Word	Byte	Bit 7	Bit 6	Bit 5	Bit 4	Bit 3	Bit 2	Bit 1	Bit 0
	1	1	-							
		2	Speed Reference (Low Byte)							
		3	Speed Reference (High Byte)							

Name	Description
Run Fwd	Forward Run Command 0: Stop 1: Forward Run
Run Rev	Reverse Run Command 0: Stop 1: Reverse Run
Fault Reset	Fault Reset 0: - 1: Fault Reset
NetCtrl	Run command from network 0: Depends on b1-02 1: Enables the Run command from network
NetRef	Speed reference from network 0: Depends on b1-01 1: Enables the speed reference from network
Speed Reference	Speed Command Sets drive speed reference. Speed reference data: Frequency reference/2 ^{SS} (SS: Speed scale) Setting range: 0 - FFFF (Hex.) For example, when setting a reference of 4096 with a speed scale of 2: Speed reference data = 4096/2 ² = 1024 = 400 (Hex.) Unit depends on o1-03.

◆ EtherNet/IP Speed and Torque Control Output - 22 (0x16)

Output Instance	Word	Byte	Bit 7	Bit 6	Bit 5	Bit 4	Bit 3	Bit 2	Bit 1	Bit 0
22	0	0	-	-	-	-	-	Fault Reset	-	Run Fwd
		1	-							
	1	2	Speed Reference (Low Byte)							
		3	Speed Reference (High Byte)							
	2	4	Torque Reference/Torque Limit (Low Byte)							
		5	Torque Reference/Torque Limit (High Byte)							

Name	Description
Run Fwd	Forward Run Command 0: Stop 1: Forward Run
Fault Reset	Fault Reset 0: - 1: Fault Reset
Speed Reference	Speed Command Sets drive speed reference. Speed reference data: Frequency reference/2 ^{SS} (SS: Speed scale) Setting range: 0 - FFFF (Hex.) For example, when setting a reference of 4096 with a speed scale of 2: Speed reference data = 4096/2 ² = 1024 = 400 (Hex.) Unit depends on o1-03.
Torque Reference/Torque Limit	Torque Reference/Torque Limit Sets the Torque Reference/Torque Limit. Sets in units of 0.1%. Sets the Torque Reference when using Torque Control [d5-01 = 1]. Sets the Torque Limit when using Speed Control [d5-01 = 0]. The Torque Reference/Torque Limit are disabled when F6-06 = 0.

◆ EtherNet/IP Extended Speed and Torque Control Output - 23 (0x17)

Output Instance	Word	Byte	Bit 7	Bit 6	Bit 5	Bit 4	Bit 3	Bit 2	Bit 1	Bit 0	
23	0	0	-	NetRef	NetCtrl	-	-	Fault Reset	Run Rev	Run Fwd	
		1	-								
	1	2	Speed Reference (Low Byte)								
		3	Speed Reference (High Byte)								
	2	4	Torque Reference/Torque Limit (Low Byte)								
		5	Torque Reference/Torque Limit (High Byte)								

Name	Description
Run Fwd	Forward Run Command 0: Stop 1: Forward Run
Run Rev	Reverse Run Command 0: Stop 1: Reverse Run
Fault Reset	Fault Reset 0: - 1: Fault Reset
NetCtrl	Run command is from network 0: Depends on b1-02 1: Run command is from network
NetRef	Speed reference is from network 0: Depends on b1-01 1: Speed reference is from network
Speed Reference	Sets drive speed reference. Speed reference data: Frequency reference x 2 ^{SS} (SS: Speed scale) Setting range: 0 - FFFF (Hex.) For example, when setting a reference of 4096 with a speed scale of 2: Speed reference data = 4096/2 ² = 1024 = 400 (Hex.) Unit depends on o1-03.
Torque Reference/Torque Limit	Sets the Torque Reference/Torque Limit. Sets in units of 0.1%. Sets the Torque Reference when using Torque Control [d5-01 = 1]. Sets the Torque Limit when using Speed Control [d5-01 = 0]. The Torque Reference/Torque Limit are disabled when F6-06 = 0.

◆ MEMOBUS/Modbus Message Output (Vendor Specific Yaskawa Electric (YE Assy) - 100 (0x64)

Output Instance	Word	Byte	Bit 7	Bit 6	Bit 5	Bit 4	Bit 3	Bit 2	Bit 1	Bit 0
100	0	0	Function Code							
		1	Register Number (High Byte)							
	1	2	Register Number (Low Byte)							
		3	Register Data (High Byte)							
	2	4	Register Data (Low Byte)							

Note:

This is a paired assembly (100/150).

Name	Description
Function Code	MEMOBUS/Modbus Function Code
Register Number	MEMOBUS/Modbus Register Number
Register Data	MEMOBUS/Modbus Register Data

Table 8.1 Function Code Decode Table

Function Code	MEMOBUS/Modbus Function
0x00	No Operation
0x03	Read Register
0x10	Write Register

Note:

Refer to the MEMOBUS/Modbus Data Table in Appendix C of the Technical Manual for a list of monitor data using the MEMOBUS/Modbus message area.

◆ (Vendor Specific Yaskawa Electric (YE) Assy) Speed/Torque Control Output - 101 (0x65)

Output Instance	Word	Byte	Bit 7	Bit 6	Bit 5	Bit 4	Bit 3	Bit 2	Bit 1	Bit 0	
101	0	0	Multi-Function Input 8	Multi-Function Input 7	Multi-Function Input 6	Multi-Function Input 5	Multi-Function Input 4	Multi-Function Input 3	Run Rev	Run Fwd	
		1	Multi-Function Digital Output 3	Multi-Function Digital Output 2	Multi-Function Digital Output 1	-	-	-	Fault Reset	External Fault	
	1	2	Speed Reference (Low Byte)								
		3	Speed Reference (High Byte)								
	2	4	Torque Reference/Torque Limit (Low Byte)								
		5	Torque Reference/Torque Limit (High Byte)								
	3	6	Torque Compensation (Low Byte)								
		7	Torque Compensation (High Byte)								

Name	Description
Run Fwd	Forward Run Command 0: Stop 1: Forward Run
Run Rev	Reverse Run Command 0: Stop 1: Reverse Run
Multi-Function Input 3	Terminal S3 Function Input 0: Terminal S3 Function [H1-03] OFF 1: Terminal S3 Function [H1-03] ON
Multi-Function Input 4	Terminal S4 Function Input 0: Terminal S4 Function [H1-04] OFF 1: Terminal S4 Function [H1-04] ON
Multi-Function Input 5	Terminal S5 Function Input 0: Terminal S5 Function [H1-05] OFF 1: Terminal S5 Function [H1-05] ON
Multi-Function Input 6	Terminal S6 Function Input 0: Terminal S6 Function [H1-06] OFF 1: Terminal S6 Function [H1-06] ON
Multi-Function Input 7	Terminal S7 Function Input 0: Terminal S7 Function [H1-07] OFF 1: Terminal S7 Function [H1-07] ON
Multi-Function Input 8	Terminal S8 Function Input 0: Terminal S8 Function [H1-08] OFF 1: Terminal S8 Function [H1-08] ON
External Fault	External Fault EF0 0: - 1: External Fault [EF0]
Fault Reset	Fault Reset 0: - 1: Fault Reset
Multi-Function Digital Output 1	Terminal M1/M2 (varies by drive model) 0: M1/M2 OFF 1: M1/M2 ON

8 Output Assemblies (Drive Consumes)

Name	Description
	This function is enabled only when H2-01 is set to F. Note: The names of the digital outputs are different for different drive series.
Multi-Function Digital Output 2	Terminal M3/M4 (varies by drive model) 0: M3/M4 OFF 1: M3/M4 ON This function is enabled only when H2-02 is set to F. Note: The names of the digital outputs are different for different drive series.
Multi-Function Digital Output 3	Terminal M5/M6 (varies by drive model) 0: M5/M6 OFF 1: M5/M6 ON This function is enabled only when H2-03 is set to F. Note: The names of the digital outputs are different for different drive series.
Speed Reference	Speed Command Sets drive speed reference. Unit depends on o1-03. Unit is not affected by Speed Scale SS.
Torque Reference/Torque Limit	Torque Reference/Torque Limit Sets the Torque Reference/Torque Limit. Sets in units of 0.1%. Sets the Torque Reference when using Torque Control [d5-01 = 1]. Sets the Torque Limit when using Speed Control [d5-01 = 0]. The Torque Reference/Torque Limit are disabled when F6-06 = 0.
Torque Compensation	Torque Compensation Sets the amount of Torque Compensation Sets in units of 0.1%.

◆ (Vendor Specific Yaskawa Electric (YE) Assy) Extended Speed/Torque Control Output - 115 (0x73)

Output Instance	Word	Byte	Bit 7	Bit 6	Bit 5	Bit 4	Bit 3	Bit 2	Bit 1	Bit 0	
115	0	0	Multi-Function Input 8	Multi-Function Input 7	Multi-Function Input 6	Multi-Function Input 5	Multi-Function Input 4	Multi-Function Input 3	Run Rev	Run Fwd	
		1	Multi-Function Digital Output 3	Multi-Function Digital Output 2	Multi-Function Digital Output 1	-	-	-	Fault Reset	External Fault	
	1	2	Speed Reference (Low Byte)								
		3	Speed Reference (High Byte)								
	2	4	Torque Reference/Torque Limit (Low Byte)								
		5	Torque Reference/Torque Limit (High Byte)								
	3	6	Torque Compensation (Low Byte)								
		7	Torque Compensation (High Byte)								
	4 - 5	8 - 11	Reserved								
	6	12	Analog Output 1 (Low Byte)								
		13	Analog Output 1 (High Byte)								
	7	14	Analog Output 2 (Low Byte)								
		15	Analog Output 2 (High Byte)								
	8	16	Digital Outputs (Low Byte)								
		17	Digital Outputs (High Byte)								
	9 - 19	18 - 39	Reserved								

Name	Description
Run Fwd	Forward Run Command 0: Stop 1: Forward Run
Run Rev	Reverse Run Command

Name	Description
	0: Stop 1: Reverse Run
Multi-Function Input 3	Terminal S3 Function Input 0: Terminal S3 Function [H1-03] OFF 1: Terminal S3 Function [H1-03] ON
Multi-Function Input 4	Terminal S4 Function Input 0: Terminal S4 Function [H1-04] OFF 1: Terminal S4 Function [H1-04] ON
Multi-Function Input 5	Terminal S5 Function Input 0: Terminal S5 Function [H1-05] OFF 1: Terminal S5 Function [H1-05] ON
Multi-Function Input 6	Terminal S6 Function Input 0: Terminal S6 Function [H1-06] OFF 1: Terminal S6 Function [H1-06] ON
Multi-Function Input 7	Terminal S7 Function Input 0: Terminal S7 Function [H1-07] OFF 1: Terminal S7 Function [H1-07] ON
Multi-Function Input 8	Terminal S8 Function Input 0: Terminal S8 Function [H1-08] OFF 1: Terminal S8 Function [H1-08] ON
External Fault	External Fault EF0 0: - 1: External Fault [EF0]
Fault Reset	Fault Reset 0: - 1: Fault Reset
Multi-Function Digital Output 1	Terminal M1/M2 (varies by drive model) 0: M1/M2 OFF 1: M1/M2 ON This function is enabled only when H2-01 is set to F. Note: The names of the digital outputs are different for different drive series.
Multi-Function Digital Output 2	Terminal M3/M4 (varies by drive model) 0: M3/M4 OFF 1: M3/M4 ON This function is enabled only when H2-02 is set to F. Note: The names of the digital outputs are different for different drive series.
Multi-Function Digital Output 3	Terminal M5/M6 (varies by drive model) 0: M5/M6 OFF 1: M5/M6 ON This function is enabled only when H2-03 is set to F. Note: The names of the digital outputs are different for different drive series.
Speed Reference	Speed Command Sets drive speed reference. Unit is min^{-1} or determined by o1-03.
Torque Reference/Torque Limit	Torque Reference/Torque Limit Sets the Torque Reference/Torque Limit. Sets in units of 0.1%. Sets the Torque Reference when using Torque Control [d5-01 = 1]. Sets the Torque Limit when using Speed Control [d5-01 = 0]. The Torque Reference/Torque Limit are disabled when F6-06 = 0.
Torque Compensation	Torque Compensation Sets the amount of Torque Compensation Sets in units of 0.1%.
Analog Output 1	MEMOBUS/Modbus (0x0007)
Analog Output 2	MEMOBUS/Modbus (0x0008)
Digital Outputs	MEMOBUS/Modbus (0x0009) Note: These values are ORed with values in byte 1.

◆ (Vendor Specific Yaskawa Electric (YE) Assy)-High Speed/Torque Control Output - 116 (0x74)

The first 20 Bytes (0-19) are fixed and the next 20 Bytes can be configured using parameters *F7-23* to *F7-32*. If an error occurs while trying to write to the dynamic parameters, the appropriate error bit in Assembly 166 will be set. If more information is needed as to the nature of the error, the extended error status can be read explicitly through Class 4, Instance 0xA6, Attribute 0x64. This will return 20 Bytes with each dynamic parameter in Assembly 116 having a Byte dedicated to its extended error status.

Output Instance	Word	Byte	Bit 7	Bit 6	Bit 5	Bit 4	Bit 3	Bit 2	Bit 1	Bit 0	
116	0	0	Multi-Function Input 8	Multi-Function Input 7	Multi-Function Input 6	Multi-Function Input 5	Multi-Function Input 4	Multi-Function Input 3	Run Rev	Run Fwd	
		1	Multi-Function Digital Output 3	Multi-Function Digital Output 2	Multi-Function Digital Output 1	-	-	-	Fault Reset	External Fault	
	1	2	Speed Reference (Low Byte)								
		3	Speed Reference (High Byte)								
	2	4	Torque Reference/Torque Limit (Low Byte)								
		5	Torque Reference/Torque Limit (High Byte)								
	3	6	Torque Compensation (Low Byte)								
		7	Torque Compensation (High Byte)								
	4	8	Reserved								
		9	-	-	-	-	Multi-Function Input 12	Multi-Function Input 11	Multi-Function Input 10	Multi-Function Input 9	
	5	10	-	-	-	-	-	-	NetCtrl	NetRef	
		11	-	-	-	-	-	-	-	-	
	6	12	Analog Output 1 (Low Byte)								
		13	Analog Output 1 (High Byte)								
	7	14	Analog Output 2 (Low Byte)								
		15	Analog Output 2 (High Byte)								
	8	16	Digital Outputs (Low Byte)								
		17	Digital Outputs (High Byte)								
	9	18	Reserved								
		19	Reserved								
	10	20 - 21	Dynamic Output 1 [F7-23], Default: Not Used								
	11	22 - 23	Dynamic Output 2 [F7-24], Default: Not Used								
	12	24 - 25	Dynamic Output 3 [F7-25], Default: Not Used								
	13	26 - 27	Dynamic Output 4 [F7-26], Default: Not Used								
	14	28 - 29	Dynamic Output 5 [F7-27], Default: Not Used								
	15	30 - 31	Dynamic Output 6 [F7-28], Default: Not Used								
	16	32 - 33	Dynamic Output 7 [F7-29], Default: Not Used								
	17	34 - 35	Dynamic Output 8 [F7-30], Default: Not Used								
	18	36 - 37	Dynamic Output 9 [F7-31], Default: Not Used								
	19	38 - 39	Dynamic Output 10 [F7-32], Default: Not Used								
		20 - 21	40 - 43	Not Used							

Name	Description
Run Fwd	Forward Run Command 0: Stop 1: Forward Run
Run Rev	Reverse Run Command 0: Stop

Name	Description
	1: Reverse Run
Multi-Function Input 3	Terminal S3 Function Input 0: Terminal S3 Function [H1-03] OFF 1: Terminal S3 Function [H1-03] ON
Multi-Function Input 4	Terminal S4 Function Input 0: Terminal S4 Function [H1-04] OFF 1: Terminal S4 Function [H1-04] ON
Multi-Function Input 5	Terminal S5 Function Input 0: Terminal S5 Function [H1-05] OFF 1: Terminal S5 Function [H1-05] ON
Multi-Function Input 6	Terminal S6 Function Input 0: Terminal S6 Function [H1-06] OFF 1: Terminal S6 Function [H1-06] ON
Multi-Function Input 7	Terminal S7 Function Input 0: Terminal S7 Function [H1-07] OFF 1: Terminal S7 Function [H1-07] ON
Multi-Function Input 8	Terminal S8 Function Input 0: Terminal S8 Function [H1-08] OFF 1: Terminal S8 Function [H1-08] ON
External Fault	External Fault EF0 0: - 1: External Fault [EF0]
Fault Reset	Fault Reset 0: - 1: Fault Reset
Multi-Function Digital Output 1	Terminal M1/M2 (varies by drive model) 0: M1/M2 OFF 1: M1/M2 ON This function is enabled only when H2-01 is set to F. Note: The names of the digital outputs are different for different drive series.
Multi-Function Digital Output 2	Terminal M3/M4 (varies by drive model) 0: M3/M4 OFF 1: M3/M4 ON This function is enabled only when H2-02 is set to F. Note: The names of the digital outputs are different for different drive series.
Multi-Function Digital Output 3	Terminal M5/M6 (varies by drive model) 0: M5/M6 OFF 1: M5/M6 ON This function is enabled only when H2-03 is set to F. Note: The names of the digital outputs are different for different drive series.
Speed Reference	Speed Command Sets drive speed reference. Unit is min^{-1} or determined by o1-03.
Torque Reference/Torque Limit	Torque Reference/Torque Limit Sets the Torque Reference/Torque Limit. Sets in units of 0.1%. Sets the Torque Reference when using Torque Control [d5-01 = 1]. Sets the Torque Limit when using Speed Control [d5-01 = 0]. The Torque Reference/Torque Limit are disabled when F6-06 = 0.
Torque Compensation	Torque Compensation Sets the amount of Torque Compensation Sets in units of 0.1%.
Digital Inputs	Sets digital inputs 9-12 if the drive supports them.
NetRef	Network sets reference
NetCtrl	Network sets control
Analog Output 1	MEMOBUS/Modbus (0x0007)
Analog Output 2	MEMOBUS/Modbus (0x0008)

8 Output Assemblies (Drive Consumes)

Name	Description
Digital Outputs	MEMOBUS/Modbus (0x0009) Note: These values are ORed with values in byte 1.
Dynamic Outputs	Contains the data to be written to the MEMOBUS/Modbus address defined in the given parameter. A value of 0 in the given parameter means it is not used, therefore the value received for this given parameter will not be written to any MEMOBUS/Modbus register. If the PPA is Input Assembly 166, then any errors occurring during a write will be flagged. Refer to page 58 for more information.

◆ (Vendor Specific Yaskawa Electric (YE) Assy) 8 Byte Dynamic Output - 117 (0x75)

Output Instance	Word	Byte	Bit 7	Bit 6	Bit 5	Bit 4	Bit 3	Bit 2	Bit 1	Bit 0	
117	0	0	Multi-Function Input 8	Multi-Function Input 7	Multi-Function Input 6	Multi-Function Input 5	Multi-Function Input 4	Multi-Function Input 3	Run Rev	Run Fwd	
		1	Multi-Function Digital Output 3	Multi-Function Digital Output 2	Multi-Function Digital Output 1	-	-	-	Fault Reset	External Fault	
	1	2	Speed Reference (Low Byte)								
		3	Speed Reference (High Byte)								
	2	4 - 5	Dynamic Output 1 [F7-23], Default: Not Used								
	3	6 - 7	Dynamic Output 2 [F7-24], Default: Not Used								

Name	Description
Run Fwd	Forward Run Command 0: Stop 1: Forward Run
Run Rev	Reverse Run Command 0: Stop 1: Reverse Run
Multi-Function Input 3	Terminal S3 Function Input 0: Terminal S3 Function [H1-03] OFF 1: Terminal S3 Function [H1-03] ON
Multi-Function Input 4	Terminal S4 Function Input 0: Terminal S4 Function [H1-04] OFF 1: Terminal S4 Function [H1-04] ON
Multi-Function Input 5	Terminal S5 Function Input 0: Terminal S5 Function [H1-05] OFF 1: Terminal S5 Function [H1-05] ON
Multi-Function Input 6	Terminal S6 Function Input 0: Terminal S6 Function [H1-06] OFF 1: Terminal S6 Function [H1-06] ON
Multi-Function Input 7	Terminal S7 Function Input 0: Terminal S7 Function [H1-07] OFF 1: Terminal S7 Function [H1-07] ON
Multi-Function Input 8	Terminal S8 Function Input 0: Terminal S8 Function [H1-08] OFF 1: Terminal S8 Function [H1-08] ON
External Fault	External Fault EF0 0: - 1: External Fault [EF0]
Fault Reset	Fault Reset 0: - 1: Fault Reset
Multi-Function Digital Output 1	Terminal M1/M2 (varies by drive model) 0: M1/M2 OFF 1: M1/M2 ON This function is enabled only when H2-01 is set to F. Note: The names of the digital outputs are different for different drive series.
Multi-Function Digital Output 2	Terminal M3/M4 (varies by drive model) 0: M3/M4 OFF

Name	Description
	1: M3/M4 ON This function is enabled only when H2-02 is set to F. Note: The names of the digital outputs are different for different drive series.
Multi-Function Digital Output 3	Terminal M5/M6 (varies by drive model) 0: M5/M6 OFF 1: M5/M6 ON This function is enabled only when H2-03 is set to F. Note: The names of the digital outputs are different for different drive series.
Speed Reference	Speed Command Sets drive speed reference. Unit is min ⁻¹ or determined by o1-03. Unit is not affected by Speed Scale SS.
Dynamic Outputs	Contains the data to be written to the MEMOBUS/Modbus address defined in the given parameter. A value of 0 in the given parameter means it is not used, therefore the value received for this given parameter will not be written to any MEMOBUS/Modbus register. If the PPA is Input Assembly 166, then any errors occurring during a write will be flagged. Refer to page 58 for more information.

◆ (Vendor Specific Yaskawa Electric (YE) Assy) 12 Byte Dynamic Output - 118 (0x76)

Output Instance	Word	Byte	Bit 7	Bit 6	Bit 5	Bit 4	Bit 3	Bit 2	Bit 1	Bit 0	
118	0	0	Multi-Function Input 8	Multi-Function Input 7	Multi-Function Input 6	Multi-Function Input 5	Multi-Function Input 4	Multi-Function Input 3	Run Rev	Run Fwd	
		1	Multi-Function Digital Output 3	Multi-Function Digital Output 2	Multi-Function Digital Output 1	-	-	-	Fault Reset	External Fault	
	1	2	Speed Reference (Low Byte)								
		3	Speed Reference (High Byte)								
	2	4 - 5	Dynamic Output 1 [F7-23], Default: Not Used								
	3	6 - 7	Dynamic Output 2 [F7-24], Default: Not Used								
	4	8 - 9	Dynamic Output 3 [F7-25], Default: Not Used								
	5	10 - 11	Dynamic Output 4 [F7-26], Default: Not Used								

Name	Description
Run Fwd	Forward Run Command 0: Stop 1: Forward Run
Run Rev	Reverse Run Command 0: Stop 1: Reverse Run
Multi-Function Input 3	Terminal S3 Function Input 0: Terminal S3 Function [H1-03] OFF 1: Terminal S3 Function [H1-03] ON
Multi-Function Input 4	Terminal S4 Function Input 0: Terminal S4 Function [H1-04] OFF 1: Terminal S4 Function [H1-04] ON
Multi-Function Input 5	Terminal S5 Function Input 0: Terminal S5 Function [H1-05] OFF 1: Terminal S5 Function [H1-05] ON
Multi-Function Input 6	Terminal S6 Function Input 0: Terminal S6 Function [H1-06] OFF 1: Terminal S6 Function [H1-06] ON
Multi-Function Input 7	Terminal S7 Function Input 0: Terminal S7 Function [H1-07] OFF 1: Terminal S7 Function [H1-07] ON
Multi-Function Input 8	Terminal S8 Function Input 0: Terminal S8 Function [H1-08] OFF 1: Terminal S8 Function [H1-08] ON

8 Output Assemblies (Drive Consumes)

Name	Description
External Fault	External Fault EF0 0: - 1: External Fault [EF0]
Fault Reset	Fault Reset 0: - 1: Fault Reset
Multi-Function Digital Output 1	Terminal M1/M2 (varies by drive model) 0: M1/M2 OFF 1: M1/M2 ON This function is enabled only when H2-01 is set to F. Note: The names of the digital outputs are different for different drive series.
Multi-Function Digital Output 2	Terminal M3/M4 (varies by drive model) 0: M3/M4 OFF 1: M3/M4 ON This function is enabled only when H2-02 is set to F. Note: The names of the digital outputs are different for different drive series.
Multi-Function Digital Output 3	Terminal M5/M6 (varies by drive model) 0: M5/M6 OFF 1: M5/M6 ON This function is enabled only when H2-03 is set to F. Note: The names of the digital outputs are different for different drive series.
Speed Reference	Speed Command Sets drive speed reference. Unit is min^{-1} or determined by o1-03. Unit is not affected by Speed Scale SS.
Dynamic Outputs	Contains the data to be written to the MEMOBUS/Modbus address defined in the given parameter. A value of 0 in the given parameter means it is not used, therefore the value received for this given parameter will not be written to any MEMOBUS/Modbus register. If the PPA is Input Assembly 166, then any errors occurring during a write will be flagged. Refer to page 58 for more information.

◆ (Vendor Specific Yaskawa Electric (YE) Assy) 18 Byte Dynamic Output - 119 (0x77)

Output Instance	Word	Byte	Bit 7	Bit 6	Bit 5	Bit 4	Bit 3	Bit 2	Bit 1	Bit 0	
119	0	0	Multi-Function Input 8	Multi-Function Input 7	Multi-Function Input 6	Multi-Function Input 5	Multi-Function Input 4	Multi-Function Input 3	Run Rev	Run Fwd	
		1	Multi-Function Digital Output 3	Multi-Function Digital Output 2	Multi-Function Digital Output 1	-	-	-	Fault Reset	External Fault	
	1	2	Speed Reference (Low Byte)								
		3	Speed Reference (High Byte)								
	2	4 - 5	Dynamic Output 1 [F7-23], Default: Not Used								
	3	6 - 7	Dynamic Output 2 [F7-24], Default: Not Used								
	4	8 - 9	Dynamic Output 3 [F7-25], Default: Not Used								
	5	10 - 11	Dynamic Output 4 [F7-26], Default: Not Used								
	6	12 - 13	Dynamic Output 5 [F7-27], Default: Not Used								
	7	14 - 15	Dynamic Output 6 [F7-28], Default: Not Used								
8	16 - 17	Dynamic Output 7 [F7-29], Default: Not Used									

Name	Description
Run Fwd	Forward Run Command 0: Stop 1: Forward Run
Run Rev	Reverse Run Command 0: Stop 1: Reverse Run
Multi-Function Input 3	Terminal S3 Function Input

Name	Description
	0: Terminal S3 Function [H1-03] OFF 1: Terminal S3 Function [H1-03] ON
Multi-Function Input 4	Terminal S4 Function Input 0: Terminal S4 Function [H1-04] OFF 1: Terminal S4 Function [H1-04] ON
Multi-Function Input 5	Terminal S5 Function Input 0: Terminal S5 Function [H1-05] OFF 1: Terminal S5 Function [H1-05] ON
Multi-Function Input 6	Terminal S6 Function Input 0: Terminal S6 Function [H1-06] OFF 1: Terminal S6 Function [H1-06] ON
Multi-Function Input 7	Terminal S7 Function Input 0: Terminal S7 Function [H1-07] OFF 1: Terminal S7 Function [H1-07] ON
Multi-Function Input 8	Terminal S8 Function Input 0: Terminal S8 Function [H1-08] OFF 1: Terminal S8 Function [H1-08] ON
External Fault	External Fault EF0 0: - 1: External Fault [EF0]
Fault Reset	Fault Reset 0: - 1: Fault Reset
Multi-Function Digital Output 1	Terminal M1/M2 (varies by drive model) 0: M1/M2 OFF 1: M1/M2 ON This function is enabled only when H2-01 is set to F. Note: The names of the digital outputs are different for different drive series.
Multi-Function Digital Output 2	Terminal M3/M4 (varies by drive model) 0: M3/M4 OFF 1: M3/M4 ON This function is enabled only when H2-02 is set to F. Note: The names of the digital outputs are different for different drive series.
Multi-Function Digital Output 3	Terminal M5/M6 (varies by drive model) 0: M5/M6 OFF 1: M5/M6 ON This function is enabled only when H2-03 is set to F. Note: The names of the digital outputs are different for different drive series.
Speed Reference	Speed Command Sets drive speed reference. Unit is min ⁻¹ or determined by o1-03. Unit is not affected by Speed Scale SS.
Dynamic Outputs	Contains the data to be written to the MEMOBUS/Modbus address defined in the given parameter. A value of 0 in the given parameter means it is not used, therefore the value received for this given parameter will not be written to any MEMOBUS/Modbus register. If the PPA is Input Assembly 166, then any errors occurring during a write will be flagged. Refer to page 58 for more information.

◆ (Vendor Specific Yaskawa Electric (YE) Assy) 24 Byte Dynamic Output - 120 (0x78)

Output Instance	Word	Byte	Bit 7	Bit 6	Bit 5	Bit 4	Bit 3	Bit 2	Bit 1	Bit 0	
120	0	0	Multi-Function Input 8	Multi-Function Input 7	Multi-Function Input 6	Multi-Function Input 5	Multi-Function Input 4	Multi-Function Input 3	Run Rev	Run Fwd	
		1	Multi-Function Digital Output 3	Multi-Function Digital Output 2	Multi-Function Digital Output 1	-	-	-	Fault Reset	External Fault	
	1	2	Speed Reference (Low Byte)								
		3	Speed Reference (High Byte)								
	2	4 - 5	Dynamic Output 1 [F7-23], Default: Not Used								

8 Output Assemblies (Drive Consumes)

Output Instance	Word	Byte	Bit 7	Bit 6	Bit 5	Bit 4	Bit 3	Bit 2	Bit 1	Bit 0
	3	6 - 7	Dynamic Output 2 [F7-24], Default: Not Used							
	4	8 - 9	Dynamic Output 3 [F7-25], Default: Not Used							
	5	10 - 11	Dynamic Output 4 [F7-26], Default: Not Used							
	6	12 - 13	Dynamic Output 5 [F7-27], Default: Not Used							
	7	14 - 15	Dynamic Output 6 [F7-28], Default: Not Used							
	8	16 - 17	Dynamic Output 7 [F7-29], Default: Not Used							
	9	18 - 19	Dynamic Output 8 [F7-30], Default: Not Used							
	10	20 - 21	Dynamic Output 9 [F7-31], Default: Not Used							
	11	22 - 23	Dynamic Output 10 [F7-32], Default: Not Used							

Name	Description
Run Fwd	Forward Run Command 0: Stop 1: Forward Run
Run Rev	Reverse Run Command 0: Stop 1: Reverse Run
Multi-Function Input 3	Terminal S3 Function Input 0: Terminal S3 Function [H1-03] OFF 1: Terminal S3 Function [H1-03] ON
Multi-Function Input 4	Terminal S4 Function Input 0: Terminal S4 Function [H1-04] OFF 1: Terminal S4 Function [H1-04] ON
Multi-Function Input 5	Terminal S5 Function Input 0: Terminal S5 Function [H1-05] OFF 1: Terminal S5 Function [H1-05] ON
Multi-Function Input 6	Terminal S6 Function Input 0: Terminal S6 Function [H1-06] OFF 1: Terminal S6 Function [H1-06] ON
Multi-Function Input 7	Terminal S7 Function Input 0: Terminal S7 Function [H1-07] OFF 1: Terminal S7 Function [H1-07] ON
Multi-Function Input 8	Terminal S8 Function Input 0: Terminal S8 Function [H1-08] OFF 1: Terminal S8 Function [H1-08] ON
External Fault	External Fault EF0 0: - 1: External Fault [EF0]
Fault Reset	Fault Reset 0: - 1: Fault Reset
Multi-Function Digital Output 1	Terminal M1/M2 (varies by drive model) 0: M1/M2 OFF 1: M1/M2 ON This function is enabled only when H2-01 is set to F. Note: The names of the digital outputs are different for different drive series.
Multi-Function Digital Output 2	Terminal M3/M4 (varies by drive model) 0: M3/M4 OFF 1: M3/M4 ON This function is enabled only when H2-02 is set to F. Note: The names of the digital outputs are different for different drive series.
Multi-Function Digital Output 3	Terminal M5/M6 (varies by drive model) 0: M5/M6 OFF 1: M5/M6 ON This function is enabled only when H2-03 is set to F. Note: The names of the digital outputs are different for different drive series.

Name	Description
Speed Reference	Speed Command Sets drive speed reference. Unit is min^{-1} or determined by o1-03. Unit is not affected by Speed Scale SS.
Dynamic Outputs	Contains the data to be written to the MEMOBUS/Modbus address defined in the given parameter. A value of 0 in the given parameter means it is not used, therefore the value received for this given parameter will not be written to any MEMOBUS/Modbus register. If the PPA is Input Assembly 166, then any errors occurring during a write will be flagged. Refer to page 58 for more information.

9 Input Assemblies (Drive Produces)

Note:

The convention in this manual is from the PLC perspective. An “Input Assembly” is outputted from this node and read by the PLC. This section details “Input Assemblies” that are “Produced” by the drive.

◆ EtherNet/IP Basic Speed Control Input - 70 (0x46)

Input Instance	Word	Byte	Bit 7	Bit 6	Bit 5	Bit 4	Bit 3	Bit 2	Bit 1	Bit 0	
70	0	0	-	-	-	-	-	Running 1 (FWD)	-	Faulted	
		1	-								
	1	2	Speed Actual (Low Byte)								
		3	Speed Actual (High Byte)								

Name	Description
Faulted	Faulted 0: No Fault 1: Fault
Running 1 (FWD)	Forward Running 0: Stop or Reverse Running 1: Forward Running
Speed Actual	Actual Drive Speed Monitors drive output frequency. Speed actual data: Output frequency x 2^{SS} (SS: Speed scale) Range: 0 - FFFF (Hex.) For example, when output frequency of 1024 with a speed scale of 2: Speed actual data = $1024 \times 2^2 = 4096 = 1000$ (Hex.) Unit depends on o1-03.

◆ EtherNet/IP Extended Speed Control Input - 71 (0x47)

Input Instance	Word	Byte	Bit 7	Bit 6	Bit 5	Bit 4	Bit 3	Bit 2	Bit 1	Bit 0	
71	0	0	Speed Agree	NetRef	NetCtrl	Ready	Running 2 (REV)	Running 1 (FWD)	Alarm	Faulted	
		1	State								
	1	2	Speed Actual (Low Byte)								
		3	Speed Actual (High Byte)								

Name	Description
Faulted	Faulted 0: No Fault 1: Fault
Alarm	Alarm 0: No Alarm 1: Alarm
Running 1 (FWD)	Forward Running 0: Stop or Reverse Running 1: Forward Running
Running 2 (REV)	Reverse Running 0: Stop or Forward Running 1: Reverse Running

9 Input Assemblies (Drive Produces)

Name	Description
Ready	Ready 0: Not Ready 1: Ready
NetCtrl	Run command is from network 0: Run command is not from network 1: Run command is from network
NetRef	Speed reference is from network 0: Speed reference is not from network 1: Speed reference is from network
Speed Agree	Speed Agree 0: - 1: Speed actual at speed reference
State	Contains the value from the Control Supervisor (Class 0x29) Instance 1 Attribute 6.
Speed Actual	Actual Drive Speed Monitors drive output frequency. Speed actual data: Output frequency x 2 ^{SS} (SS: Speed scale) Range: 0 - FFFF (Hex.) For example, when output frequency of 1024 with a speed scale of 2: Speed actual data = 1024 x 2 ² = 4096 = 0x1000 Unit depends on o1-03.

◆ EtherNet/IP Speed and Torque Control Input - 72 (0x48)

Input Instance	Word	Byte	Bit 7	Bit 6	Bit 5	Bit 4	Bit 3	Bit 2	Bit 1	Bit 0	
72	0	0	-	-	-	-	-	Running 1 (FWD)	-	Faulted	
		1	-								
	1	2	Speed Actual (Low Byte)								
		3	Speed Actual (High Byte)								
	2	4	Torque Actual (Low Byte)								
		5	Torque Actual (High Byte)								

Name	Description
Faulted	Faulted 0: No Fault 1: Fault
Running 1 (FWD)	Forward Running 0: Stop or Reverse Running 1: Forward Running
Speed Actual	Actual Drive Speed Monitors drive output frequency. Speed actual data: Output frequency x 2 ^{SS} (SS: Speed scale) Range: 0 - FFFF (Hex.) For example, when output frequency of 1024 with a speed scale of 2: Speed actual data = 1024 x 2 ² = 4096 = 1000 (Hex.) Unit depends on o1-03.
Torque Actual	Output Torque Shows the Torque Reference. Value displays in 0.1% units.

◆ EtherNet/IP Extended Speed and Torque Control Input - 73 (0x49)

Input Instance	Word	Byte	Bit 7	Bit 6	Bit 5	Bit 4	Bit 3	Bit 2	Bit 1	Bit 0	
73	0	0	Speed Agree	NetRef	NetCtrl	Ready	Running 2 (REV)	Running 1 (FWD)	Alarm	Faulted	
		1	State								
	1	2	Speed Actual (Low Byte)								
		3	Speed Actual (High Byte)								
	2	4	Torque Actual (Low Byte)								

Input Instance	Word	Byte	Bit 7	Bit 6	Bit 5	Bit 4	Bit 3	Bit 2	Bit 1	Bit 0
		5	Torque Actual (High Byte)							

Name	Description
Faulted	Faulted 0: No Fault 1: Fault
Alarm	Alarm 0: No Alarm 1: Alarm
Running 1 (FWD)	Forward Running 0: Stop or Reverse Running 1: Forward Running
Running 2 (REV)	Reverse Running 0: Stop or Forward Running 1: Reverse Running
Ready	Ready 0: Not Ready 1: Ready
NetCtrl	Run command is from network 0: Run command is not from network 1: Run command is from network
NetRef	Speed reference is from network 0: Speed reference is not from network 1: Speed reference is from network
Speed Agree	Speed Agree 0: - 1: Speed actual at speed reference
State	Contains the value from the Control Supervisor (Class 0x29) Instance 1 Attribute 6.
Speed Actual	Actual Drive Speed Monitors drive output frequency. Speed actual data: Output frequency x 2 ^{SS} (SS: Speed scale) Range: 0 - FFFF (Hex.) For example, when output frequency of 1024 with a speed scale of 2: Speed actual data = 1024 x 2 ² = 4096 = 1000 (Hex.) Unit depends on o1-03.
Torque Actual	Output Torque Shows the Torque Reference. Value displays in 0.1% units.

◆ (Vendor Specific Yaskawa Electric (YE) Assy) MEMOBUS/Modbus Message Input - 150 (0x96)

Input Instance	Word	Byte	Bit 7	Bit 6	Bit 5	Bit 4	Bit 3	Bit 2	Bit 1	Bit 0
150	0	0	Function Code							
		1	Register Number (High Byte)							
	1	2	Register Number (Low Byte)							
		3	Register Data (High Byte)							
	2	4	Register Data (Low Byte)							

Note:

This is a paired assembly (100/150).

Table 9.1 Reply Mapping - 150

Byte	Write Success	Read Success	Write Failure	Read Failure	Invalid Function Code	Function Code Equals Zero
0	0x10	0x03	0x90	0x83	Function Code Or-ed with 0x80	0
1	Output Assembly Register Number (High Byte)	Output Assembly Register Number (High Byte)	Output Assembly Register Number (High Byte)	Output Assembly Register Number (High Byte)	Output Assembly Register Number (High Byte)	0
2	Output Assembly Register Number (Low Byte)	Output Assembly Register Number (Low Byte)	Output Assembly Register Number (Low Byte)	Output Assembly Register Number (Low Byte)	Output Assembly Register Number (Low Byte)	0

9 Input Assemblies (Drive Produces)

Byte	Write Success	Read Success	Write Failure	Read Failure	Invalid Function Code	Function Code Equals Zero
3	0	Read Data (High Byte)	0	0	0	0
4	0	Read Data (Low Byte)	Error Code	Error Code	1	0

Table 9.2 Error Replies - 150

Error Code	Description
0x01	Invalid Function Code
0x02	Invalid Register Number
0x21	Upper/Lower Limit Error
0x22	Write Mode Error Option generated busy event. The MEMOBUS/Modbus requested operation is in the process loop but the drive is not done yet. Writing "Enter" when drive is running. Attempt to write data that is read only. Attempt to write a parameter when drive is running. During a CPF03 event attempting to write to registers other than A1-00 to A1-05, E1-03, o2-04.
0x23	Writing Error during Undervoltage Attempting to write during a drive Uv [undervoltage] event.
0x24	Writing Error during Parameter Processing Attempting to write while the drive is storing data.

Note:

Refer to the MEMOBUS/Modbus Data Table in Appendix C of the drive Technical Manual for a list of monitor data using the MEMOBUS/Modbus message area.

◆ (Vendor Specific Yaskawa Electric (YE) Assy) Speed/Torque Status Input - 151 (0x97)

Input Instance	Word	Byte	Bit 7	Bit 6	Bit 5	Bit 4	Bit 3	Bit 2	Bit 1	Bit 0	
151	0	0	Faulted	Alarm	Ready	Speed Agree	Reset	REV Running	ZSP	Running	
		1	ZSV	-	Multi-Function Digital Output 3	Multi-Function Digital Output 2	Multi-Function Digital Output 1	LOCAL/REMOTE	Uv	oPE	
	1	2	Output Frequency (Low Byte)								
		3	Output Frequency (High Byte)								
	2	4	Torque Actual (Low Byte)								
		5	Torque Actual (High Byte)								
	3	6	Current Actual (Low Byte)								
		7	Current Actual (High Byte)								

Name	Description
Running	Running 0: Stop 1: Forward or Reverse Running
ZSP	Zero Speed 0: Running 1: Stop or DC Injection Braking
REV Running	Reverse Running 0: Not Reverse Running 1: Reverse Running
Reset	Reset 0: - 1: Reset
Speed Agree	Speed Agree 0: - 1: Speed actual at speed reference
Ready	Ready 0: Not Ready

Name	Description
	1: Ready
Alarm	Alarm 0: No Alarm 1: Alarm
Faulted	Faulted 0: No Fault 1: Fault
oPE	oPE 0: - 1: oPExx
Uv	Undervoltage 0: - 1: Undervoltage
LOCAL/REMOTE	Run command is from network 0: Run command is not from network 1: Run command is from network
Multi-Function Digital Output 1	Terminal M1/M2 (varies by drive model) 0: M1/M2 OFF 1: M1/M2 ON This function is enabled only when H2-01 is set to F. Note: The names of the digital outputs are different for different drive series.
Multi-Function Digital Output 2	Terminal M3/M4 (varies by drive model) 0: M3/M4 OFF 1: M3/M4 ON This function is enabled only when H2-02 is set to F. Note: The names of the digital outputs are different for different drive series.
Multi-Function Digital Output 3	Terminal M5/M6 (varies by drive model) 0: M5/M6 OFF 1: M5/M6 ON This function is enabled only when H2-03 is set to F. Note: The names of the digital outputs are different for different drive series.
ZSV	Zero Servo Completed 0: - 1: Zero Servo Completed
Output Frequency	Actual Drive Speed Monitors drive output frequency. Unit depends on o1-03. Unit is not affected by Speed Scale SS.
Torque Actual	Output Torque Shows the Torque Reference. Value displays in 0.1% units.
Current Actual	Actual Output Current Monitors drive output current. Unit: 0.1 A Unit is not affected by Current Scale CS.

◆ (Vendor Specific Yaskawa Electric (YE) Assy) Extended Speed/Torque Status Input - 155 (0x9B)

Input Instance	Word	Byte	Bit 7	Bit 6	Bit 5	Bit 4	Bit 3	Bit 2	Bit 1	Bit 0	
155	0	0	Faulted	Alarm	Ready	Speed Agree	Fault Reset	REV Running	ZSP	Running	
		1	ZSV	-	Multi-Function Digital Output 3	Multi-Function Digital Output 2	Multi-Function Digital Output 1	LOCAL/REMOTE	Uv	oPE	
	1	2	Motor Speed (Low Byte)								
		3	Motor Speed (High Byte)								
	2	4	Torque Actual (Low Byte)								
		5	Torque Actual (High Byte)								

9 Input Assemblies (Drive Produces)

Input Instance	Word	Byte	Bit 7	Bit 6	Bit 5	Bit 4	Bit 3	Bit 2	Bit 1	Bit 0
	3	6	PG Count Value (Low Byte)							
		7	PG Count Value (High Byte)							
	4	8	Frequency Command (Low Byte)							
		9	Frequency Command (High Byte)							
	5	10	Output Frequency (Low Byte)							
		11	Output Frequency (High Byte)							
	6	12	Output Current (Low Byte)							
		13	Output Current (High Byte)							
	7	14	Terminal A2 Input (Low Byte)							
		15	Terminal A2 Input (High Byte)							
	8	16	Main Circuit DC Voltage (Low Byte)							
		17	Main Circuit DC Voltage (High Byte)							
	9	18	Error Alarm Signal 1 (Low Byte)							
		19	Error Alarm Signal 1 (High Byte)							
	10	20	Error Alarm Signal 2 (Low Byte)							
		21	Error Alarm Signal 2 (High Byte)							
	11	22	Error Alarm Signal 3 (Low Byte)							
		23	Error Alarm Signal 3 (High Byte)							
	12	24	Terminal A3 Input (Low Byte)							
		25	Terminal A3 Input (High Byte)							
	13	26	Terminal S1 to S8 Input (Low Byte)							
		27	Terminal S1 to S8 Input (High Byte)							
	14	28	Terminal A1 Input (Low Byte)							
		29	Terminal A1 Input (High Byte)							
	15	30	PG Counter (Ch2) (Low Byte)							
		31	PG Counter (Ch2) (High Byte)							
	16 - 19	32 - 39	Reserved							

Name	Description
Running	Running 0: Stop 1: Forward or Reverse Running
ZSP	Zero Speed 0: Running 1: Stop or DC Injection Braking
REV Running	Reverse Running 0: Not Reverse Running 1: Reverse Running
Fault Reset	Fault Reset 0: - 1: Fault Reset
Speed Agree	Speed Agree 0: - 1: Speed actual at speed reference
Ready	Ready 0: Not Ready 1: Ready
Alarm	Alarm 0: No Alarm 1: Alarm
Faulted	Faulted 0: No Fault 1: Fault

Name	Description
oPE	oPE 0: - 1: oPExx
Uv	Undervoltage 0: - 1: Undervoltage
LOCAL/REMOTE	Run command is from network 0: Run command is not from network 1: Run command is from network
Multi-Function Digital Output 1	Terminal M1/M2 (varies by drive model) 0: M1/M2 OFF 1: M1/M2 ON This function is enabled only when H2-01 is set to F. Note: The names of the digital outputs are different for different drive series.
Multi-Function Digital Output 2	Terminal M3/M4 (varies by drive model) 0: M3/M4 OFF 1: M3/M4 ON This function is enabled only when H2-02 is set to F. Note: The names of the digital outputs are different for different drive series.
Multi-Function Digital Output 3	Terminal M5/M6 (varies by drive model) 0: M5/M6 OFF 1: M5/M6 ON This function is enabled only when H2-03 is set to F. Note: The names of the digital outputs are different for different drive series.
ZSV	Zero Servo Completed 0: - 1: Zero Servo Completed
Motor Speed	Monitor parameter U1-05
Torque Actual	Output Torque Shows the torque reference. Value displays in 0.1% units.
PG Count Value	MEMOBUS/Modbus (0x7CD) PG1 Count value register U6-18
Frequency Command	Monitor parameter U1-01
Output Frequency	Actual Drive Speed Monitors drive output frequency. Unit depends on o1-03. Unit is not affected by Speed Scale SS.
Output Current	Actual Output Current Monitors drive output current. Unit: 0.01A Unit is not affected by Current Scale CS.
Terminal A2 Input	MEMOBUS/Modbus (0x4F) Monitor parameter U1-14
Main Circuit DC Voltage	Main Circuit DC Voltage Monitor parameter U1-07
Error Alarm Signal 1	Error Alarm Signal 1 MEMOBUS/Modbus (0xC8)
Error Alarm Signal 2	Error Alarm Signal 2 MEMOBUS/Modbus (0xC9)
Error Alarm Signal 3	Error Alarm Signal 3 MEMOBUS/Modbus (0xCA)
Terminal A3 Input	MEMOBUS/Modbus (0x50) Monitor parameter U1-15
Terminal S1 to S8 Input	MEMOBUS/Modbus (0x49) Monitor parameter U1-10

Name	Description
Terminal A1 Input	MEMOBUS/Modbus (0x46) Monitor parameter U1-13
PG Counter (Ch2)	MEMOBUS/Modbus (0x7E5) PG Pulse Count for Channel 2 U6-19

◆ (Vendor Specific Yaskawa Electric (YE) Assy) High Speed/Torque Status Input - 166 (0xA6)

If an error occurs while trying to read from the dynamic parameters, the appropriate error bit in Assembly 166 will be set. If more information about the nature of the error is needed, the extended error status can be read explicitly through Class 4, Instance 0xA6, Attribute 0x64. This will return 20 Bytes with each dynamic parameter in Assembly 166 having a Byte dedicated to its extended error status.

Input Instance	Word	Byte	Bit 7	Bit 6	Bit 5	Bit 4	Bit 3	Bit 2	Bit 1	Bit 0	
166	0	0	Faulted	Alarm	Ready	Speed Agree	Fault Reset	REV Running	ZSP	Running	
		1	ZSV	-	Multi-Function Digital Output 3	Multi-Function Digital Output 2	Multi-Function Digital Output 1	LOCAL/REMOTE	Uv	oPE	
	1	2	Motor Speed (Low Byte)								
		3	Motor Speed (High Byte)								
	2	4	Torque Actual (Low Byte)								
		5	Torque Actual (High Byte)								
	3	6	PG Count Value (Low Byte)								
		7	PG Count Value (High Byte)								
	4	8	Frequency Command (Low Byte)								
		9	Frequency Command (High Byte)								
	5	10	Output Frequency (Low Byte)								
		11	Output Frequency (High Byte)								
	6	12	Output Current (Low Byte)								
		13	Output Current (High Byte)								
	7	14	Parameter [F7-35], Default: Terminal A1 Input (Low Byte)								
		15	Parameter [F7-35], Default: Terminal A1 Input (High Byte)								
	8	16	Main Circuit DC Voltage (Low Byte)								
		17	Main Circuit DC Voltage (High Byte)								
	9	18	Error Code (Low Byte)								
		19	Error Code (High Byte)								
	10 *I	20 *I	Parameter [F7-33], Default: Alarm Code (Low Byte)								
		21 *I	Parameter [F7-33], Default: Alarm Code (High Byte)								
	11 *I	22 *I	Parameter [F7-34], Default: Output Power (Low Byte)								
		23 *I	Parameter [F7-34], Default: Output Power (High Byte)								
	12 *I	24 *I	Parameter [F7-35], Default: Terminal A2 Input (Low Byte)								
		25 *I	Parameter [F7-35], Default: Terminal A2 Input (High Byte)								
	13 *I	26 *I	Parameter [F7-36], Default: Terminal S1 to S8 Input (Low Byte)								
		27 *I	Parameter [F7-36], Default: Terminal S1 to S8 Input (High Byte)								
	14 *I	28 *I	Parameter [F7-37], Default: Terminal A3 Input (Low Byte)								
		29 *I	Parameter [F7-37], Default: Terminal A3 Input (High Byte)								
	15 *I	30 *I	Parameter [F7-38], Default: PG Counter (Ch2) (Low Byte)								
		31 *I	Parameter [F7-38], Default: PG Counter (Ch2) (High Byte)								
16 *I	32 *I	Parameter [F7-39], Default: NetRef and NetCtrl (Low Byte)									
		-	-	-	-	-	-	-	NetCtrl	NetRef	

Input Instance	Word	Byte	Bit 7	Bit 6	Bit 5	Bit 4	Bit 3	Bit 2	Bit 1	Bit 0	
		33 */	Parameter [F7-39], Default: NetRef and NetCtrl (High Byte)								
	17 */	34 */	Parameter [F7-40], Default: Drive Software Version (Low Byte)								
		35 */	Parameter [F7-40], Default: Drive Software Version (High Byte)								
	18 */	36 */	Parameter [F7-41] (Low Byte), Default: Not Used								
		37 */	Parameter [F7-41] (High Byte), Default: Not Used								
	19 */	38 */	Parameter [F7-42] (Low Byte), Default: Not Used								
		39 */	Parameter [F7-42] (High Byte), Default: Not Used								
	20	40	-	-	-	-	-	-	-	Assy. 116 F7-32 Error	Assy. 116 F7-31 Error
		41	Assy. 116 F7-30 Error	Assy. 116 F7-29 Error	Assy. 116 F7-28 Error	Assy. 116 F7-27 Error	Assy. 116 F7-26 Error	Assy. 116 F7-25 Error	Assy. 116 F7-24 Error	Assy. 116 F7-23 Error	
	21	42	-	-	-	-	-	-	-	Assy. 166 F7-42 Error	Assy. 166 F7-41 Error
43		Assy. 166 F7-40 Error	Assy. 166 F7-39 Error	Assy. 166 F7-38 Error	Assy. 166 F7-37 Error	Assy. 166 F7-36 Error	Assy. 166 F7-35 Error	Assy. 166 F7-34 Error	Assy. 166 F7-33 Error		

*1 Selectable with F7-33 to F7-42.

Name	Description
Running	Running 0: Stop 1: Forward or Reverse Running
ZSP	Zero Speed 0: Running 1: Stop or DC Injection Braking
REV Running	Reverse Running 0: Not Reverse Running 1: Reverse Running
Fault Reset	Fault Reset 0: - 1: Fault Reset
Speed Agree	Speed Agree 0: - 1: Speed actual at speed reference
Ready	Ready 0: Not Ready 1: Ready
Alarm	Alarm 0: No Alarm 1: Alarm
Faulted	Faulted 0: No Fault 1: Fault
oPE	oPE 0: - 1: oPExx
Uv	Undervoltage 0: - 1: Undervoltage
LOCAL/REMOTE	Run command is from network 0: Run command is not from network 1: Run command is from network
Multi-Function Digital Output 1	Terminal M1/M2 (varies by drive model) 0: M1/M2 OFF 1: M1/M2 ON This function is enabled only when H2-01 is set to F. Note: The names of the digital outputs are different for different drive series.
Multi-Function Digital Output 2	Terminal M3/M4 (varies by drive model) 0: M3/M4 OFF 1: M3/M4 ON This function is enabled only when H2-02 is set to F.

9 Input Assemblies (Drive Produces)

Name	Description
	Note: The names of the digital outputs are different for different drive series.
Multi-Function Digital Output 3	Terminal M5/M6 (varies by drive model) 0: M5/M6 OFF 1: M5/M6 ON This function is enabled only when H2-03 is set to F. Note: The names of the digital outputs are different for different drive series.
ZSV	Zero Servo Completed 0: - 1: Zero Servo Completed
Motor Speed	Monitor parameter U1-05
Torque Actual	Output Torque Shows the Torque Reference. Value displays in 0.1% units.
PG Count Value	Contained MEMOBUS/Modbus Address PG1 Count value register (0xF0)
Frequency Command	Monitor parameter U1-01
Output Frequency	Actual Drive Speed Monitors drive output frequency. Unit depends on o1-03. Unit is not affected by Speed Scale SS.
Output Current	Actual Output Current Monitors drive output current. Unit: 0.01A Unit is not affected by Current Scale CS.
Terminal A1 Input	MEMOBUS/Modbus (0x46) Monitor parameter U1-13
Main Circuit DC Voltage	Main Circuit DC Voltage Monitor parameter U1-07
Error Code	U2-01 converted using fault code table.
F7-33 Alarm Code	Programmable: MEMOBUS/Modbus (0x7F)
F7-34 Output Power	Programmable: MEMOBUS/Modbus (0x47) Monitor parameter U1-08
F7-35 Terminal A2 Input	Programmable: MEMOBUS/Modbus (0x4F) Monitor parameter U1-14
F7-36 Terminal S1 to S8	Programmable: MEMOBUS/Modbus (0x49) Monitor parameter U1-10
F7-37 Terminal A3 Input	Programmable: MEMOBUS/Modbus (0x50)
F7-38 PG Count Value (Ch2)	Programmable: MEMOBUS/Modbus (0x7E5) PG Pulse Count for Channel 2 U6-19
F7-39 NetRef (Status)	Speed reference is from network 0: Speed reference is not from network 1: Speed reference is from network
F7-40 Drive Software Version	Programmable: MEMOBUS/Modbus (0x4D) Monitor parameter U1-25

Possible extended error codes are listed in [Table 9.3](#) and [Table 9.4](#). If an error occurs, extended error code 0x02 (Register number failure) is usually set.

Table 9.3 Extended Error Codes for Assembly 116/166

Error Code	Description
0x00	No Fault
0x01	Sub function code failure
0x02	Register Number
0x21	Limit check error failure
0x22	Write Failure

Error Code	Description
0x23	Write failure at Uv
0x24	Write failure at busy

Table 9.4 Extended Error Codes in Class 0x04, Instance 0xA6, Attribute 0x64

Dynamic Parameter	Byte Containing Extended Error Code
F7-23	Byte 0
F7-24	Byte 1
F7-25	Byte 2
F7-26	Byte 3
F7-27	Byte 4
F7-28	Byte 5
F7-29	Byte 6
F7-30	Byte 7
F7-31	Byte 8
F7-32	Byte 9
F7-33	Byte 10
F7-34	Byte 11
F7-35	Byte 12
F7-36	Byte 13
F7-37	Byte 14
F7-38	Byte 15
F7-39	Byte 16
F7-40	Byte 17
F7-41	Byte 18
F7-42	Byte 19

◆ **(Vendor Specific Yaskawa Electric (YE) Assy) 8-Byte Dynamic Input - 167 (0xA7)**

Input Instance	Word	Byte	Bit 7	Bit 6	Bit 5	Bit 4	Bit 3	Bit 2	Bit 1	Bit 0	
167	0	0	Faulted	Alarm	Ready	Speed Agree	Fault Reset	REV Running	ZSP	Running	
		1	ZSV	-	Multi-Function Digital Output 3	Multi-Function Digital Output 2	Multi-Function Digital Output 1	LOCAL/REMOTE	Uv	oPE	
	1	2	Output Frequency (Low Byte)								
		3	Output Frequency (High Byte)								
	2	4 - 5	Dynamic Input 1 [F7-33], Default: Alarm Code								
	3	6 - 7	Dynamic Input 2 [F7-34], Default: Output Power [U1-08]								

Name	Description
Running	Running 0: Stop 1: Forward or Reverse Running
ZSP	Zero Speed 0: Running 1: Stop or DC Injection Braking
REV Running	Reverse Running 0: Not Reverse Running 1: Reverse Running
Fault Reset	Fault Reset 0: - 1: Fault Reset

9 Input Assemblies (Drive Produces)

Name	Description
Speed Agree	Speed Agree 0: - 1: Speed actual at speed reference
Ready	Ready 0: Not Ready 1: Ready
Alarm	Alarm 0: No Alarm 1: Alarm
Faulted	Faulted 0: No Fault 1: Fault
oPE	oPE 0: - 1: oPExx
Uv	Undervoltage 0: - 1: Undervoltage
LOCAL/REMOTE	Run command is from network 0: Run command is not from network 1: Run command is from network
Multi-Function Digital Output 1	Terminal M1/M2 (varies by drive model) 0: M1/M2 OFF 1: M1/M2 ON This function is enabled only when H2-01 is set to F. Note: The names of the digital outputs are different for different drive series.
Multi-Function Digital Output 2	Terminal M3/M4 (varies by drive model) 0: M3/M4 OFF 1: M3/M4 ON This function is enabled only when H2-02 is set to F. Note: The names of the digital outputs are different for different drive series.
Multi-Function Digital Output 3	Terminal M5/M6 (varies by drive model) 0: M5/M6 OFF 1: M5/M6 ON This function is enabled only when H2-03 is set to F. Note: The names of the digital outputs are different for different drive series.
Output Frequency	Actual Drive Speed Monitors drive output frequency. Unit depends on o1-03. Unit is not affected by Speed Scale SS.
Dynamic Inputs	Contains the data to be read from the MEMOBUS/Modbus address defined in the given parameter. A value of 0 in the given parameter means it will return the default data as defined in the table above.

◆ (Vendor Specific Yaskawa Electric (YE) Assy) 12-Byte Dynamic Input - 168 (0xA8)

Input Instance	Word	Byte	Bit 7	Bit 6	Bit 5	Bit 4	Bit 3	Bit 2	Bit 1	Bit 0	
168	0	0	Faulted	Alarm	Ready	Speed Agree	Fault Reset	REV Running	ZSP	Running	
		1	ZSV	-	Multi-Function Digital Output 3	Multi-Function Digital Output 2	Multi-Function Digital Output 1	LOCAL/REMOTE	Uv	oPE	
	1	2	Output Frequency (Low Byte)								
		3	Output Frequency (High Byte)								
	2	4 - 5	Dynamic Input 1 [F7-33], Default: Alarm Code								
	3	6 - 7	Dynamic Input 2 [F7-34], Default: Output Power [U1-08]								
	4	8 - 9	Dynamic Input 3 [F7-35], Default: Analog Input 2								
	5	10 - 11	Dynamic Input 4 [F7-36], Default: Digital Input								

Name	Description
Running	Running 0: Stop 1: Forward or Reverse Running
ZSP	Zero Speed 0: Running 1: Stop or DC Injection Braking
REV Running	Reverse Running 0: Not Reverse Running 1: Reverse Running
Fault Reset	Fault Reset 0: - 1: Fault Reset
Speed Agree	Speed Agree 0: - 1: Speed actual at speed reference
Ready	Ready 0: Not Ready 1: Ready
Alarm	Alarm 0: No Alarm 1: Alarm
Faulted	Faulted 0: No Fault 1: Fault
oPE	oPE 0: - 1: oPExx
Uv	Undervoltage 0: - 1: Undervoltage
LOCAL/REMOTE	Run command is from network 0: Run command is not from network 1: Run command is from network
Multi-Function Digital Output 1	Terminal M1/M2 (varies by drive model) 0: M1/M2 OFF 1: M1/M2 ON This function is enabled only when H2-01 is set to F. Note: The names of the digital outputs are different for different drive series.
Multi-Function Digital Output 2	Terminal M3/M4 (varies by drive model) 0: M3/M4 OFF 1: M3/M4 ON This function is enabled only when H2-02 is set to F. Note: The names of the digital outputs are different for different drive series.
Multi-Function Digital Output 3	Terminal M5/M6 (varies by drive model) 0: M5/M6 OFF 1: M5/M6 ON This function is enabled only when H2-03 is set to F. Note: The names of the digital outputs are different for different drive series.
Output Frequency	Actual Drive Speed Monitors drive output frequency. Unit depends on o1-03. Unit is not affected by Speed Scale SS.
Dynamic Inputs	Contains the data to be read from the MEMOBUS/Modbus address defined in the given parameter. A value of 0 in the given parameter means it will return the default data as defined in the table above.

◆ (Vendor Specific Yaskawa Electric (YE) Assy) 18-Byte Dynamic Input - 169 (0xA9)

Input Instance	Word	Byte	Bit 7	Bit 6	Bit 5	Bit 4	Bit 3	Bit 2	Bit 1	Bit 0
169	0	0	Faulted	Alarm	Ready	Speed Agree	Fault Reset	REV Running	ZSP	Running

9 Input Assemblies (Drive Produces)

Input Instance	Word	Byte	Bit 7	Bit 6	Bit 5	Bit 4	Bit 3	Bit 2	Bit 1	Bit 0
		1	ZSV	-	Multi-Function Digital Output 3	Multi-Function Digital Output 2	Multi-Function Digital Output 1	LOCAL/REMOTE	Uv	oPE
1	2	Output Frequency (Low Byte)								
	3	Output Frequency (High Byte)								
2	4 - 5	Dynamic Input 1 [F7-33], Default: Fault Code								
3	6 - 7	Dynamic Input 2 [F7-34], Default: Output Power [U1-08]								
4	8 - 9	Dynamic Input 3 [F7-35], Default: Analog Input 2								
5	10 - 11	Dynamic Input 4 [F7-36], Default: Digital Input								
6	12 - 13	Dynamic Input 5 [F7-37], Default: Analog Input 3								
7	14 - 15	Dynamic Input 6 [F7-38], Default: PG 2 Counter								
8	16 - 17	Dynamic Input 7 [F7-39], Default: Net Ref and Net Ctrl								

Name	Description
Running	Running 0: Stop 1: Forward or Reverse Running
ZSP	Zero Speed 0: Running 1: Stop or DC Injection Braking
REV Running	Reverse Running 0: Not Reverse Running 1: Reverse Running
Fault Reset	Fault Reset 0: - 1: Fault Reset
Speed Agree	Speed Agree 0: - 1: Speed actual at speed reference
Ready	Ready 0: Not Ready 1: Ready
Alarm	Alarm 0: No Alarm 1: Alarm
Faulted	Faulted 0: No Fault 1: Fault
oPE	oPE 0: - 1: oPExx
Uv	Undervoltage 0: - 1: Undervoltage
LOCAL/REMOTE	Run command is from network 0: Run command is not from network 1: Run command is from network
Multi-Function Digital Output 1	Terminal M1/M2 (varies by drive model) 0: M1/M2 OFF 1: M1/M2 ON This function is enabled only when H2-01 is set to F. Note: The names of the digital outputs are different for different drive series.
Multi-Function Digital Output 2	Terminal M3/M4 (varies by drive model) 0: M3/M4 OFF 1: M3/M4 ON This function is enabled only when H2-02 is set to F. Note: The names of the digital outputs are different for different drive series.
Multi-Function Digital Output 3	Terminal M5/M6 (varies by drive model)

Name	Description
	0: M5/M6 OFF 1: M5/M6 ON This function is enabled only when H2-03 is set to F. Note: The names of the digital outputs are different for different drive series.
Output Frequency	Actual Drive Speed Monitors drive output frequency. Unit depends on o1-03. Unit is not affected by Speed Scale SS.
Dynamic Inputs	Contains the data to be read from the MEMOBUS/Modbus address defined in the given parameter. A value of 0 in the given parameter means it will return the default data as defined in the table above.

◆ (Vendor Specific Yaskawa Electric (YE) Assy) 24-Byte Dynamic Input - 170 (0xAA)

Input Instance	Word	Byte	Bit 7	Bit 6	Bit 5	Bit 4	Bit 3	Bit 2	Bit 1	Bit 0	
170	0	0	Faulted	Alarm	Ready	Speed Agree	Fault Reset	REV Running	ZSP	Running	
		1	ZSV	-	Multi-Function Digital Output 3	Multi-Function Digital Output 2	Multi-Function Digital Output 1	LOCAL/REMOTE	Uv	oPE	
	1	2	Output Frequency (Low Byte)								
		3	Output Frequency (High Byte)								
	2	4 - 5	Dynamic Input 1 [F7-33], Default: Fault Code								
	3	6 - 7	Dynamic Input 2 [F7-34], Default: Output Power [U1-08]								
	4	8 - 9	Dynamic Input 3 [F7-35], Default: Analog Input 2								
	5	10 - 11	Dynamic Input 4 [F7-36], Default: Digital Input								
	6	12 - 13	Dynamic Input 5 [F7-37], Default: Analog Input 3								
	7	14 - 15	Dynamic Input 6 [F7-38], Default: PG 2 Counter								
	8	16 - 17	Dynamic Input 7 [F7-39], Default: Net Ref and Net Ctrl								
	9	18 - 19	Dynamic Input 8 [F7-40], Default: Drive Software Version								
10	20 - 21	Dynamic Input 9 [F7-41], Default: Not Used									
11	22 - 23	Dynamic Input 10 [F7-42], Default: Not Used									

Name	Description
Running	Running 0: Stop 1: Forward or Reverse Running
ZSP	Zero Speed 0: Running 1: Stop or DC Injection Braking
REV Running	Reverse Running 0: Not Reverse Running 1: Reverse Running
Fault Reset	Fault Reset 0: - 1: Fault Reset
Speed Agree	Speed Agree 0: - 1: Speed actual at speed reference
Ready	Ready 0: Not Ready 1: Ready
Alarm	Alarm 0: No Alarm 1: Alarm
Faulted	Faulted 0: No Fault 1: Fault

10 Output Assemblies (Converter Consumes)

Name	Description
oPE	oPE 0: - 1: oPExx
Uv	Undervoltage 0: - 1: Undervoltage
LOCAL/REMOTE	Run command is from network 0: Run command is not from network 1: Run command is from network
Multi-Function Digital Output 1	Terminal M1/M2 (varies by drive model) 0: M1/M2 OFF 1: M1/M2 ON This function is enabled only when H2-01 is set to F. Note: The names of the digital outputs are different for different drive series.
Multi-Function Digital Output 2	Terminal M3/M4 (varies by drive model) 0: M3/M4 OFF 1: M3/M4 ON This function is enabled only when H2-02 is set to F. Note: The names of the digital outputs are different for different drive series.
Multi-Function Digital Output 3	Terminal M5/M6 (varies by drive model) 0: M5/M6 OFF 1: M5/M6 ON This function is enabled only when H2-03 is set to F. Note: The names of the digital outputs are different for different drive series.
Output Frequency	Actual Drive Speed Monitors drive output frequency. Unit depends on o1-03. Unit is not affected by Speed Scale SS.
Dynamic Inputs	Contains the data to be read from the MEMOBUS/Modbus address defined in the given parameter. A value of 0 in the given parameter means it will return the default data as defined in the table above.

10 Output Assemblies (Converter Consumes)

Note:

The convention in this manual is from the PLC perspective. As such, an assembly is called an "Output Assembly" when outputted from the PLC and received by this node. This section details "Output Assemblies" that are "Consumed" by the converter.

◆ EtherNet/IP Basic Speed Control Output - 20 (0x14)

Output Instance	Word	Byte	Bit 7	Bit 6	Bit 5	Bit 4	Bit 3	Bit 2	Bit 1	Bit 0	
20	0	0	-	-	-	-	-	Fault Reset	-	D1000: Run R1000: Auto Run	
		1	-								
	1	2	D1000: Voltage Reference (Low Byte) R1000: -								
		3	D1000: Voltage Reference (High Byte) R1000: -								

Name	Description
D1000: Run R1000: Auto Run	D1000: Run converter 0: Stop 1: Run R1000: Run converter in auto 0: Stop 1: Auto Run
Fault Reset	Fault Reset 0: - 1: Fault Reset
D1000: Voltage Reference (High Byte) R1000: -	D1000: Voltage Reference Sets converter voltage reference. Voltage reference data: Voltage reference/2VS (VS: Voltage scale) Setting range: 0 - FFFF (Hex.) Example: setting a reference of 4096 with a voltage scale of 2: Voltage reference data = 4096/2 ² = 1024 = 400 (Hex.) Unit depends on <i>o1-03</i> . R1000: -

◆ EtherNet/IP Extended Speed Control Output - 21 (0x15)

Output Instance	Word	Byte	Bit 7	Bit 6	Bit 5	Bit 4	Bit 3	Bit 2	Bit 1	Bit 0	
21	0	0	-	D1000: NetRef R1000: -	NetCtrl	-	-	Fault Reset	D1000: - R1000: Forced Run	D1000: Run R1000: Auto Run	
		1	-								
	1	2	D1000: Voltage Reference (Low Byte) R1000: -								
		3	D1000: Voltage Reference (High Byte) R1000: -								

Name	Description
D1000: Run R1000: Auto Run	D1000: Run converter 0: Stop 1: Run R1000: Run converter in auto 0: Stop 1: Auto Run
D1000: - R1000: Forced Run	D1000: - R1000: Force run converter 0: Stop 1: Force Run
Fault Reset	Fault Reset 0: - 1: Fault Reset
NetCtrl	Run command from network 0: Depends on <i>b1-02</i> 1: Run Command is from network
D1000: NetRef R1000: -	D1000: Voltage command from network 0: Depends on <i>b1-01</i> 1: Voltage command from network R1000: -
D1000: Voltage Reference R1000: -	D1000: Voltage Reference Sets converter voltage reference. Voltage reference data: Voltage reference/2VS (VS: Voltage scale) Setting range: 0 - FFFF (Hex.) Example: setting a reference of 4096 with a voltage scale of 2: Voltage reference data = 4096/2 ² = 1024 = 400 (Hex.) Unit depends on <i>o1-03</i> . R1000: -

◆ EtherNet/IP Speed and Torque Control Output - 22 (0x16)

Output Instance	Word	Byte	Bit 7	Bit 6	Bit 5	Bit 4	Bit 3	Bit 2	Bit 1	Bit 0	
22	0	0	-	-	-	-	-	Fault Reset	-	D1000: Run R1000: Auto Run	
		1	-								
	1	2	D1000: Voltage Reference (Low Byte) R1000: -								
		3	D1000: Voltage Reference (High Byte) R1000: -								

Name	Description
D1000: Run R1000: Auto Run	D1000: Run converter 0: Stop 1: Run R1000: Run converter in auto 0: Stop 1: Auto Run
Fault Reset	Fault Reset 0: - 1: Fault Reset
D1000: Voltage Reference R1000: -	D1000: Voltage Reference Sets converter voltage reference. Voltage reference data: Voltage reference/2VS (VS: Voltage scale) Setting range: 0 - FFFF (Hex.) Example: setting a reference of 4096 with a voltage scale of 2: Voltage reference data = $4096/2^2 = 1024 = 400$ (Hex.) Unit depends on <i>o1-03</i> . R1000: -

◆ EtherNet/IP Extended Speed and Torque Control Output - 23 (0x17)

Output Instance	Word	Byte	Bit 7	Bit 6	Bit 5	Bit 4	Bit 3	Bit 2	Bit 1	Bit 0	
23	0	0	-	D1000: NetRef R1000: -	NetCtrl	-	-	Fault Reset	D1000: - R1000: Forced Run	D1000: Run R1000: Auto Run	
		1	-								
	1	2	D1000: Voltage Reference (Low Byte) R1000: -								
		3	D1000: Voltage Reference (High Byte) R1000: -								

Name	Description
D1000: Run R1000: Auto Run	D1000: Run converter 0: Stop 1: Run R1000: Run converter in auto 0: Stop 1: Auto Run
D1000: - R1000: Forced Run	D1000: - R1000: Force run converter
Fault Reset	Fault Reset 0: - 1: Fault Reset
NetCtrl	Run command from network 0: Depends on <i>b1-02</i> 1: Enables the run command from network

Name	Description
D1000: NetRef R1000: -	D1000: Voltage command from network 0: Depends on <i>b1-01</i> 1: Voltage command from network R1000: -
D1000: Voltage Reference R1000: -	D1000: Voltage Reference Sets converter voltage reference. Voltage reference data: Voltage reference/2VS (VS: Voltage scale) Setting range: 0 - FFFF (Hex.) Example: setting a reference of 4096 with a voltage scale of 2: Voltage reference data = $4096/2^2 = 1024 = 400$ (Hex.) Unit depends on <i>o1-03</i> . R1000: -

◆ (Vendor Specific Yaskawa Electric (YE) Assy) Speed/Torque Control Output - 101 (0x65)

Output Instance	Word	Byte	Bit 7	Bit 6	Bit 5	Bit 4	Bit 3	Bit 2	Bit 1	Bit 0
101	0	0	Multi-Function Input 8	Multi-Function Input 7	Multi-Function Input 6	Multi-Function Input 5	Multi-Function Input 4	Multi-Function Input 3	D1000: - R1000: - Forced Run	D1000: Run R1000: Auto Run
		1	Multi-Function Digital Output 3	Multi-Function Digital Output 2	Multi-Function Digital Output 1	-	-	-	Fault Reset	External Fault
	1	2	D1000: Voltage Reference (Low Byte) R1000: -							
		3	D1000: Voltage Reference (High Byte) R1000: -							

Name	Description
D1000: Run R1000: Auto Run	D1000: Run converter 0: Stop 1: Run R1000: Run converter in auto 0: Stop 1: Auto Run
D1000: - R1000: Forced Run	D1000: - R1000: Force run converter 0: Stop 1: Force Run
Multi-Function Input 3	Terminal S3 Function Input 0: Terminal S3 Function [H1-03] OFF 1: Terminal S3 Function [H1-03] ON
Multi-Function Input 4	Terminal S4 Function Input 0: Terminal S4 Function [H1-04] OFF 1: Terminal S4 Function [H1-04] ON
Multi-Function Input 5	Terminal S5 Function Input 0: Terminal S5 Function [H1-05] OFF 1: Terminal S5 Function [H1-05] ON
Multi-Function Input 6	Terminal S6 Function Input 0: Terminal S6 Function [H1-06] OFF 1: Terminal S6 Function [H1-06] ON
Multi-Function Input 7	Terminal S7 Function Input 0: Terminal S7 Function [H1-07] OFF 1: Terminal S7 Function [H1-07] ON
Multi-Function Input 8	Terminal S8 Function Input 0: Terminal S8 Function [H1-08] OFF 1: Terminal S8 Function [H1-08] ON
External Fault	External Fault EF0 0: - 1: External Fault [EF0]
Fault Reset	Fault Reset 0: - 1: Fault Reset

10 Output Assemblies (Converter Consumes)

Multi-Function Digital Output 1	Terminal M1/M2 (varies by converter model) 0: M1/M2 OFF 1: M1/M2 ON This function is enabled only when H2-01 is set to F. Note: The names of the digital outputs are different for different converter series.
Multi-Function Digital Output 2	Terminals M3 and M4 0: M3/M4 OFF 1: M3/M4 ON This function is enabled only when H2-02 is set to F. Note: The names of the digital outputs are different for different converter series.
Multi-Function Digital Output 3	Terminals M5 and M6 0: M5/M6 OFF 1: M5/M6 ON This function is enabled only when H2-03 is set to F. Note: The names of the digital outputs are different for different converter series.
D1000: Voltage Reference R1000: -	D1000: Voltage Reference Sets converter voltage reference. R1000: -

◆ (Vendor Specific Yaskawa Electric (YE) Assy) Extended Speed/Torque Control Output - 115 (0x73)

Output Instance	Word	Byte	Bit 7	Bit 6	Bit 5	Bit 4	Bit 3	Bit 2	Bit 1	Bit 0	
115	0	0	Multi-Function Input 8	Multi-Function Input 7	Multi-Function Input 6	Multi-Function Input 5	Multi-Function Input 4	Multi-Function Input 3	D1000: - R1000: Forced Run	D1000: Run R1000: Auto Run	
		1	Multi-Function Digital Output 3	Multi-Function Digital Output 2	Multi-Function Digital Output 1	-	-	-	Fault Reset	External Fault	
	1	2	D1000: Voltage Reference (Low Byte) R1000: -								
		3	D1000: Voltage Reference (High Byte) R1000: -								
	2	4	-								
		5	-								
	3	6	-								
		7	-								
	4 - 5	8 - 11	Reserved								
	6	12	Analog Output 1 (Low Byte)								
		13	Analog Output 1 (High Byte)								
	7	14	Analog Output 2 (Low Byte)								
		15	Analog Output 2 (High Byte)								
	8	16	Digital Outputs (Low Byte)								
		17	Digital Outputs (High Byte)								
	9 - 19	18 - 39	Reserved								

Name	Description
D1000: Run R1000: Auto Run	D1000: Run converter 0: Stop 1: Run R1000: Run converter in auto 0: Stop 1: Auto Run
D1000: - R1000: Forced Run	D1000: - R1000: Force run converter 0: Stop 1: Force Run

Name	Description
Multi-Function Input 3	Terminal S3 Function Input 0: Terminal S3 Function [H1-03] OFF 1: Terminal S3 Function [H1-03] ON
Multi-Function Input 4	Terminal S4 Function Input 0: Terminal S4 Function [H1-04] OFF 1: Terminal S4 Function [H1-04] ON
Multi-Function Input 5	Terminal S5 Function Input 0: Terminal S5 Function [H1-05] OFF 1: Terminal S5 Function [H1-05] ON
Multi-Function Input 6	Terminal S6 Function Input 0: Terminal S6 Function [H1-06] OFF 1: Terminal S6 Function [H1-06] ON
Multi-Function Input 7	Terminal S7 Function Input 0: Terminal S7 Function [H1-07] OFF 1: Terminal S7 Function [H1-07] ON
Multi-Function Input 8	Terminal S8 Function Input 0: Terminal S8 Function [H1-08] OFF 1: Terminal S8 Function [H1-08] ON
External Fault	External Fault EF0 0: - 1: External Fault [EF0]
Fault Reset	Fault Reset 0: - 1: Fault Reset
Multi-Function Digital Output 1	Terminal M1/M2 (varies by converter model) 0: M1/M2 OFF 1: M1/M2 ON This function is enabled only when H2-01 is set to F. Note: The names of the digital outputs are different for different converter series.
Multi-Function Digital Output 2	Terminal M3/M4 (varies by converter model) 0: M3/M4 OFF 1: M3/M4 ON This function is enabled only when H2-02 is set to F. Note: The names of the digital outputs are different for different converter series.
Multi-Function Digital Output 3	Terminal M5/M6 (varies by converter model) 0: M5/M6 OFF 1: M5/M6 ON This function is enabled only when H2-03 is set to F. Note: The names of the digital outputs are different for different converter series.
D1000: Voltage Reference R1000: -	D1000: Voltage Reference Sets converter voltage reference. R1000: -
Analog Output 1	MEMOBUS/Modbus (0x0007)
Analog Output 2	MEMOBUS/Modbus (0x0008)
Digital Outputs	MEMOBUS/Modbus (0x0009) Note: Note: These values are ORed with values in byte 1.

◆ (Vendor Specific Yaskawa Electric (YE) Assy)-High Speed/Torque Control Output - 116 (0x74)

The first 20 Bytes (0-19) are fixed and the next 20 Bytes can be configured using parameters *F7-23* to *F7-32*. If an error occurs while trying to write to the dynamic parameters, the appropriate error bit in Assembly 166 will be set. If more information is needed as to the nature of the error, the extended error status can be read explicitly through Class 4, Instance 0xA6, Attribute 0x64. This will return 20 Bytes with each dynamic parameter in Assembly 116 having a Byte dedicated to its extended error status.

10 Output Assemblies (Converter Consumes)

Output Instance	Word	Byte	Bit 7	Bit 6	Bit 5	Bit 4	Bit 3	Bit 2	Bit 1	Bit 0	
116	0	0	Multi-Function Input 8	Multi-Function Input 7	Multi-Function Input 6	Multi-Function Input 5	Multi-Function Input 4	Multi-Function Input 3	D1000: - R1000: Forced Run	D1000: Run R1000: Auto Run	
		1	Multi-Function Digital Output 3	Multi-Function Digital Output 2	Multi-Function Digital Output 1	-	-	-	Fault Reset	External Fault	
	1	2	D1000: Voltage Reference (Low Byte) R1000: -								
		3	D1000: Voltage Reference (High Byte) R1000: -								
	2	4	-								
		5	-								
	3	6	-								
		7	-								
	4	8	Reserved								
		9	-	-	-	-	Multi-Function Input 12	Multi-Function Input 11	Multi-Function Input 10	Multi-Function Input 9	
	5	10	-	-	-	-	-	-	NetCtrl	D1000: NetRef R1000: -	
		11	Reserved								
	6	12	Analog Output 1 (Low Byte)								
		13	Analog Output 1 (High Byte)								
	7	14	Analog Output 2 (Low Byte)								
		15	Analog Output 2 (High Byte)								
	8	16	Digital Outputs (Low Byte)								
		17	Digital Outputs (High Byte)								
	9	18	Reserved								
		19	Reserved								
	10	20 - 21	Programmable Bytes [F7-23], Default: Not Used								
	11	22 - 23	Programmable Bytes [F7-24], Default: Not Used								
	12	24 - 25	Programmable Bytes [F7-25], Default: Not Used								
	13	26 - 27	Programmable Bytes [F7-26], Default: Not Used								
	14	28 - 29	Programmable Bytes [F7-27], Default: Not Used								
	15	30 - 31	Programmable Bytes [F7-28], Default: Not Used								
	16	32 - 33	Programmable Bytes [F7-29], Default: Not Used								
	17	34 - 35	Programmable Bytes [F7-30], Default: Not Used								
	18	36 - 37	Programmable Bytes [F7-31], Default: Not Used								
	19	38 - 39	Programmable Bytes [F7-32], Default: Not Used								
	20 - 21	40 - 43	Reserved								

Name	Description
D1000: Run R1000: Auto Run	D1000: Run converter 0: Stop 1: Run R1000: Run converter in auto 0: Stop 1: Auto Run
D1000: - R1000: Forced Run	D1000: - R1000: Force run converter 0: Stop 1: Force Run
Multi-Function Input 3	Terminal S3 Function Input 0: Terminal S3 Function [H1-03] OFF

Name	Description
	1: Terminal S3 Function [H1-03] ON
Multi-Function Input 4	Terminal S4 Function Input 0: Terminal S4 Function [H1-04] OFF 1: Terminal S4 Function [H1-04] ON
Multi-Function Input 5	Terminal S5 Function Input 0: Terminal S5 Function [H1-05] OFF 1: Terminal S5 Function [H1-05] ON
Multi-Function Input 6	Terminal S6 Function Input 0: Terminal S6 Function [H1-06] OFF 1: Terminal S6 Function [H1-06] ON
Multi-Function Input 7	Terminal S7 Function Input 0: Terminal S7 Function [H1-07] OFF 1: Terminal S7 Function [H1-07] ON
Multi-Function Input 8	Terminal S8 Function Input 0: Terminal S8 Function [H1-08] OFF 1: Terminal S8 Function [H1-08] ON
External Fault	External Fault EF0 0: - 1: External Fault [EF0]
Fault Reset	Fault Reset 0: - 1: Fault Reset
Multi-Function Digital Output 1	Terminal M1/M2 (varies by converter model) 0: M1/M2 OFF 1: M1/M2 ON This function is enabled only when H2-01 is set to F. Note: The names of the digital outputs are different for different converter series.
Multi-Function Digital Output 2	Terminal M3/M4 (varies by converter model) 0: M3/M4 OFF 1: M3/M4 ON This function is enabled only when H2-02 is set to F. Note: The names of the digital outputs are different for different converter series.
Multi-Function Digital Output 3	Terminal M5/M6 (varies by converter model) 0: M5/M6 OFF 1: M5/M6 ON This function is enabled only when H2-03 is set to F. Note: The names of the digital outputs are different for different converter series.
D1000: Voltage Reference R1000: -	D1000: Voltage Reference Sets converter voltage reference. R1000: -
Digital Inputs	Sets digital inputs 9-12 if the drive supports them.
D1000: NetRef R1000: -	D1000: Voltage command from network R1000: -
NetCtrl	Run command from network
Analog Output 1	MEMOBUS/Modbus (0x0007)
Analog Output 2	MEMOBUS/Modbus (0x0008)
Digital Outputs	MEMOBUS/Modbus (0x0009) Note: These values are ORed with values in byte 1.
Programmable Bytes	Contains the data to be written to the MEMOBUS/Modbus address defined in the given parameter. A value of 0 in the given parameter means it is not used, therefore the value received for this given parameter will not be written to any MEMOBUS/Modbus register.

◆ (Vendor Specific Yaskawa Electric (YE) Assy) 8 Byte Dynamic 2 Output - 117 (0x75)

Output Instance	Word	Byte	Bit 7	Bit 6	Bit 5	Bit 4	Bit 3	Bit 2	Bit 1	Bit 0	
117	0	0	Multi-Function Input 8	Multi-Function Input 7	Multi-Function Input 6	Multi-Function Input 5	Multi-Function Input 4	Multi-Function Input 3	D1000: - R1000: Forced Run	D1000: Run R1000: Auto Run	
		1	Multi-Function Digital Output 3	Multi-Function Digital Output 2	Multi-Function Digital Output 1	-	-	-	Fault Reset	External Fault	
	1	2	D1000: Voltage Reference (Low Byte) R1000: -								
		3	D1000: Voltage Reference (High Byte) R1000: -								
	2	4 -5	Programmable Bytes [F7-23], Default: Not Used								
	3	6 -7	Programmable Bytes [F7-24], Default: Not Used								

Name	Description
D1000: Run R1000: Auto Run	D1000: Run converter 0: Stop 1: Run R1000: Run converter in auto 0: Stop 1: Auto Run
D1000: - R1000: Forced Run	D1000: - R1000: Force run converter 0: Stop 1: Force Run
Multi-Function Input 3	Terminal S3 Function Input 0: Terminal S3 Function [H1-03] OFF 1: Terminal S3 Function [H1-03] ON
Multi-Function Input 4	Terminal S4 Function Input 0: Terminal S4 Function [H1-04] OFF 1: Terminal S4 Function [H1-04] ON
Multi-Function Input 5	Terminal S5 Function Input 0: Terminal S5 Function [H1-05] OFF 1: Terminal S5 Function [H1-05] ON
Multi-Function Input 6	Terminal S6 Function Input 0: Terminal S6 Function [H1-06] OFF 1: Terminal S6 Function [H1-06] ON
Multi-Function Input 7	Terminal S7 Function Input 0: Terminal S7 Function [H1-07] OFF 1: Terminal S7 Function [H1-07] ON
Multi-Function Input 8	Terminal S8 Function Input 0: Terminal S8 Function [H1-08] OFF 1: Terminal S8 Function [H1-08] ON
External Fault	External Fault EF0 0: - 1: External Fault [EF0]
Fault Reset	Fault Reset 0: - 1: Fault Reset
Multi-Function Digital Output 1	Terminal M1/M2 (varies by converter model) 0: M1/M2 OFF 1: M1/M2 ON This function is enabled only when H2-01 is set to F. Note: The names of the digital outputs are different for different converter series.
Multi-Function Digital Output 2	Terminal M3/M4 (varies by converter model) 0: M3/M4 OFF 1: M3/M4 ON This function is enabled only when H2-02 is set to F.

Name	Description
	Note: The names of the digital outputs are different for different converter series.
Multi-Function Digital Output 3	Terminal M5/M6 (varies by converter model) 0: M5/M6 OFF 1: M5/M6 ON This function is enabled only when H2-03 is set to F. Note: The names of the digital outputs are different for different converter series.
D1000: Voltage Reference R1000: -	D1000: Voltage Reference Sets converter voltage reference. R1000: -
Programmable Bytes	Contains the data to be written to the MEMOBUS/Modbus address defined in the given parameter. A value of 0 in the given parameter means it is not used, therefore the value received for this given parameter will not be written to any MEMOBUS/Modbus register.

◆ (Vendor Specific Yaskawa Electric (YE) Assy) 12 Byte Dynamic 4 Output - 118 (0x76)

Output Instance	Word	Byte	Bit 7	Bit 6	Bit 5	Bit 4	Bit 3	Bit 2	Bit 1	Bit 0	
118	0	0	Multi-Function Input 8	Multi-Function Input 7	Multi-Function Input 6	Multi-Function Input 5	Multi-Function Input 4	Multi-Function Input 3	D1000: - R1000: Forced Run	D1000: Run R1000: Auto Run	
		1	Multi-Function Digital Output 3	Multi-Function Digital Output 2	Multi-Function Digital Output 1	-	-	-	Fault Reset	External Fault	
	1	2	D1000: Voltage Reference (Low Byte) R1000: -								
		3	D1000: Voltage Reference (High Byte) R1000: -								
	2	4-5	Programmable Bytes [F7-23], Default: Not Used								
	3	6-7	Programmable Bytes [F7-24], Default: Not Used								
	4	8-9	Programmable Bytes [F7-25], Default: Not Used								
	5	10-11	Programmable Bytes [F7-26], Default: Not Used								

Name	Description
D1000: Run R1000: Auto Run	D1000: Run converter 0: Stop 1: Run R1000: Run converter in auto 0: Stop 1: Auto Run
D1000: - R1000: Forced Run	D1000: - R1000: Force run converter 0: Stop 1: Force Run
Multi-Function Input 3	Terminal S3 Function Input 0: Terminal S3 Function [H1-03] OFF 1: Terminal S3 Function [H1-03] ON
Multi-Function Input 4	Terminal S4 Function Input 0: Terminal S4 Function [H1-04] OFF 1: Terminal S4 Function [H1-04] ON
Multi-Function Input 5	Terminal S5 Function Input 0: Terminal S5 Function [H1-05] OFF 1: Terminal S5 Function [H1-05] ON
Multi-Function Input 6	Terminal S6 Function Input 0: Terminal S6 Function [H1-06] OFF 1: Terminal S6 Function [H1-06] ON
Multi-Function Input 7	Terminal S7 Function Input 0: Terminal S7 Function [H1-07] OFF 1: Terminal S7 Function [H1-07] ON
Multi-Function Input 8	Terminal S8 Function Input

10 Output Assemblies (Converter Consumes)

Name	Description
	0: Terminal S8 Function [H1-08] OFF 1: Terminal S8 Function [H1-08] ON
External Fault	External Fault EF0 0: - 1: External Fault [EF0]
Fault Reset	Fault Reset 0: - 1: Fault Reset
Multi-Function Digital Output 1	Terminal M1/M2 (varies by converter model) 0: M1/M2 OFF 1: M1/M2 ON This function is enabled only when H2-01 is set to F.
Multi-Function Digital Output 2	Terminals M3 and M4 0: M3/M4 OFF 1: M3/M4 ON This function is enabled only when H2-02 is set to F.
Multi-Function Digital Output 3	Terminals M5 and M6 0: M5/M6 OFF 1: M5/M6 ON This function is enabled only when H2-03 is set to F.
D1000: Voltage Reference R1000: -	D1000: Voltage Reference Sets converter voltage reference. R1000: -
Programmable Bytes	Contains the data to be written to the MEMOBUS/Modbus address defined in the given parameter. A value of 0 in the given parameter means it is not used, therefore the value received for this given parameter will not be written to any MEMOBUS/Modbus register.

◆ (Vendor Specific Yaskawa Electric (YE) Assy) 18 Byte Dynamic 7 Output - 119 (0x77)

Output Instance	Word	Byte	Bit 7	Bit 6	Bit 5	Bit 4	Bit 3	Bit 2	Bit 1	Bit 0	
119	0	0	Multi-Function Input 8	Multi-Function Input 7	Multi-Function Input 6	Multi-Function Input 5	Multi-Function Input 4	Multi-Function Input 3	D1000: - R1000: Forced Run	D1000: Run R1000: Auto Run	
		1	Multi-Function Digital Output 3	Multi-Function Digital Output 2	Multi-Function Digital Output 1	-	-	-	Fault Reset	External Fault	
	1	2	D1000: Voltage Reference (Low Byte) R1000: -								
		3	D1000: Voltage Reference (High Byte) R1000: -								
	2	4 -5	Programmable Bytes [F7-23], Default: Not Used								
	3	6 -7	Programmable Bytes [F7-24], Default: Not Used								
	4	8 -9	Programmable Bytes [F7-25], Default: Not Used								
	5	10 -11	Programmable Bytes [F7-26], Default: Not Used								
	6	12 -13	Programmable Bytes [F7-27], Default: Not Used								
	7	14 -15	Programmable Bytes [F7-28], Default: Not Used								
	8	16 -17	Programmable Bytes [F7-29], Default: Not Used								

Name	Description
D1000: Run R1000: Auto Run	D1000: Run converter 0: Stop 1: Run R1000: Run converter in auto 0: Stop 1: Auto Run
D1000: - R1000: Forced Run	D1000: - R1000: Force run converter 0: Stop 1: Force Run

Name	Description
Multi-Function Input 3	Terminal S3 Function Input 0: Terminal S3 Function [H1-03] OFF 1: Terminal S3 Function [H1-03] ON
Multi-Function Input 4	Terminal S4 Function Input 0: Terminal S4 Function [H1-04] OFF 1: Terminal S4 Function [H1-04] ON
Multi-Function Input 5	Terminal S5 Function Input 0: Terminal S5 Function [H1-05] OFF 1: Terminal S5 Function [H1-05] ON
Multi-Function Input 6	Terminal S6 Function Input 0: Terminal S6 Function [H1-06] OFF 1: Terminal S6 Function [H1-06] ON
Multi-Function Input 7	Terminal S7 Function Input 0: Terminal S7 Function [H1-07] OFF 1: Terminal S7 Function [H1-07] ON
Multi-Function Input 8	Terminal S8 Function Input 0: Terminal S8 Function [H1-08] OFF 1: Terminal S8 Function [H1-08] ON
External Fault	External Fault EF0 0: - 1: External Fault [EF0]
Fault Reset	Fault Reset 0: - 1: Fault Reset
Multi-Function Digital Output 1	Terminal M1/M2 (varies by converter model) 0: M1/M2 OFF 1: M1/M2 ON This function is enabled only when H2-01 is set to F. Note: The names of the digital outputs are different for different converter series.
Multi-Function Digital Output 2	Terminal M3/M4 (varies by converter model) 0: M3/M4 OFF 1: M3/M4 ON This function is enabled only when H2-02 is set to F. Note: The names of the digital outputs are different for different converter series.
Multi-Function Digital Output 3	Terminal M5/M6 (varies by converter model) 0: M5/M6 OFF 1: M5/M6 ON This function is enabled only when H2-03 is set to F. Note: The names of the digital outputs are different for different converter series.
D1000: Voltage Reference R1000: -	D1000: Voltage Reference Sets converter voltage reference. R1000: -
Programmable Bytes	Contains the data to be written to the MEMOBUS/Modbus address defined in the given parameter. A value of 0 in the given parameter means it is not used, therefore the value received for this given parameter will not be written to any MEMOBUS/Modbus register.

◆ (Vendor Specific Yaskawa Electric (YE) Assy) 24 Byte Dynamic 10 Output - 120 (0x78)

Output Instance	Word	Byte	Bit 7	Bit 6	Bit 5	Bit 4	Bit 3	Bit 2	Bit 1	Bit 0	
120	0	0	Multi-Function Input 8	Multi-Function Input 7	Multi-Function Input 6	Multi-Function Input 5	Multi-Function Input 4	Multi-Function Input 3	D1000: - R1000: Forced Run	D1000: Run R1000: Auto Run	
		1	Multi-Function Digital Output 3	Multi-Function Digital Output 2	Multi-Function Digital Output 1	-	-	-	Fault Reset	External Fault	
	1	2	D1000: Voltage Reference (Low Byte) R1000: -								
		3	D1000: Voltage Reference (High Byte) R1000: -								

10 Output Assemblies (Converter Consumes)

Output Instance	Word	Byte	Bit 7	Bit 6	Bit 5	Bit 4	Bit 3	Bit 2	Bit 1	Bit 0
	2	4 -5	Programmable Bytes [F7-23], Default: Not Used							
	3	6 -7	Programmable Bytes [F7-24], Default: Not Used							
	4	8 -9	Programmable Bytes [F7-25], Default: Not Used							
	5	10 -11	Programmable Bytes [F7-26], Default: Not Used							
	6	12 -13	Programmable Bytes [F7-27], Default: Not Used							
	7	14 -15	Programmable Bytes [F7-28], Default: Not Used							
	8	16 -17	Programmable Bytes [F7-29], Default: Not Used							
	9	18 -19	Programmable Bytes [F7-30], Default: Not Used							
	10	20 -21	Programmable Bytes [F7-31], Default: Not Used							
	11	22 -23	Programmable Bytes [F7-32], Default: Not Used							

Name	Description
D1000: Run R1000: Auto Run	D1000: Run converter 0: Stop 1: Run R1000: Run converter in auto 0: Stop 1: Auto Run
D1000: - R1000: Forced Run	D1000: - R1000: Force run converter 0: Stop 1: Force Run
Multi-Function Input 3	Terminal S3 Function Input 0: Terminal S3 Function [H1-03] OFF 1: Terminal S3 Function [H1-03] ON
Multi-Function Input 4	Terminal S4 Function Input 0: Terminal S4 Function [H1-04] OFF 1: Terminal S4 Function [H1-04] ON
Multi-Function Input 5	Terminal S5 Function Input 0: Terminal S5 Function [H1-05] OFF 1: Terminal S5 Function [H1-05] ON
Multi-Function Input 6	Terminal S6 Function Input 0: Terminal S6 Function [H1-06] OFF 1: Terminal S6 Function [H1-06] ON
Multi-Function Input 7	Terminal S7 Function Input 0: Terminal S7 Function [H1-07] OFF 1: Terminal S7 Function [H1-07] ON
Multi-Function Input 8	Terminal S8 Function Input 0: Terminal S8 Function [H1-08] OFF 1: Terminal S8 Function [H1-08] ON
External Fault	External Fault EF0 0: - 1: External Fault [EF0]
Fault Reset	Fault Reset 0: - 1: Fault Reset
Multi-Function Digital Output 1	Terminal M1/M2 (varies by converter model) 0: M1/M2 OFF 1: M1/M2 ON This function is enabled only when H2-01 is set to F. Note: The names of the digital outputs are different for different converter series.
Multi-Function Digital Output 2	Terminal M3/M4 (varies by converter model) 0: M3/M4 OFF 1: M3/M4 ON This function is enabled only when H2-02 is set to F. Note: The names of the digital outputs are different for different converter series.
Multi-Function Digital Output 3	Terminal M5/M6 (varies by converter model) 0: M5/M6 OFF

Name	Description
	1: M5/M6 ON This function is enabled only when H2-03 is set to F. Note: The names of the digital outputs are different for different converter series.
D1000: Voltage Reference R1000: -	D1000: Voltage Reference Sets converter voltage reference. R1000: -
Programmable Bytes	Contains the data to be written to the MEMOBUS/Modbus address defined in the given parameter. A value of 0 in the given parameter means it is not used, therefore the value received for this given parameter will not be written to any MEMOBUS/Modbus register.

11 Input Assemblies (Converter Produces)

Note:

The convention in this manual is from the PLC perspective. An “Input Assembly” is outputted from this node and read by the PLC. This section details “Input Assemblies” that are “Produced” by the converter.

◆ EtherNet/IP Basic Speed Control Input - 70 (0x46)

Input Instance	Word	Byte	Bit 7	Bit 6	Bit 5	Bit 4	Bit 3	Bit 2	Bit 1	Bit 0	
70	0	0	-	-	-	-	-	Faulted	-	Running	
		1	-								
	1	2	Voltage Actual (Low Byte)								
		3	Voltage Actual (High Byte)								

Name	Description
Running	Running
Faulted	Faulted 0: No Fault 1: Fault
Voltage Actual	Actual Converter Voltage Monitors the converter output voltage. Voltage actual data: Output Voltage x 2VS (VS: Voltage scale) Setting range: 0 - FFFF (Hex.) For example, when output voltage of 1024 with a voltage scale of 2: Voltage actual data = $1024 \times 2^2 = 4096 = 1000$ (Hex.)

◆ EtherNet/IP Extended Speed Control Input - 71 (0x47)

Input Instance	Word	Byte	Bit 7	Bit 6	Bit 5	Bit 4	Bit 3	Bit 2	Bit 1	Bit 0	
71	0	0	-	NetRef	NetCtrl	Ready	During Regenerative Operation	Running	Alarm	Faulted	
		1	State								
	1	2	Voltage Actual (Low Byte)								
		3	Voltage Actual (High Byte)								

Name	Description
Faulted	Faulted 0: No Fault 1: Fault
Alarm	Alarm 0: No Alarm 1: Alarm
Running	Running
During Regenerative Operation	Converter in regenerative operation
Ready	Ready 0: Not Ready 1: Ready

11 Input Assemblies (Converter Produces)

Name	Description
NetCtrl	Run command is from network 0: Run command is not from network 1: Run command is from network
NetRef	Voltage command is from network 0: Voltage command is not from network 1: Voltage command is from network
State	Contains the value from the Control Supervisor (Class 0x29) Instance 1 Attribute 6.
Voltage Actual	Actual Converter Voltage Monitors the converter output voltage. Speed actual data: Output Voltage x 2VS (VS: Voltage scale) Setting range: 0 - FFFF (Hex.) For example, when output voltage of 1024 with a voltage scale of 2: Voltage actual data = $1024 \times 2^2 = 4096 = 1000$ (Hex.)

◆ EtherNet/IP Speed and Torque Control Input - 72 (0x48)

Input Instance	Word	Byte	Bit 7	Bit 6	Bit 5	Bit 4	Bit 3	Bit 2	Bit 1	Bit 0	
72	0	0	-	-	-	-	-	Faulted	-	Running	
		1	-								
	1	2	Voltage Actual (Low Byte)								
		3	Voltage Actual (High Byte)								

Name	Description
Running	Running
Faulted	Faulted 0: No Fault 1: Fault
Voltage Actual	Actual Converter Voltage Monitors the converter output voltage. Voltage actual data: Output Voltage x 2VS (VS: Voltage scale) Setting range: 0 - FFFF (Hex.) For example, when output voltage of 1024 with a voltage scale of 2: Voltage actual data = $1024 \times 2^2 = 4096 = 1000$ (Hex.)

◆ EtherNet/IP Extended Speed and Torque Control Input - 73 (0x49)

Input Instance	Word	Byte	Bit 7	Bit 6	Bit 5	Bit 4	Bit 3	Bit 2	Bit 1	Bit 0	
73	0	0	-	NetRef	NetCtrl	Ready	During Regenerative Operation	Running	Alarm	Faulted	
		1	State								
	1	2	Voltage Actual (Low Byte)								
		3	Voltage Actual (High Byte)								

Name	Description
Faulted	Faulted 0: No Fault 1: Fault
Alarm	Alarm 0: No Alarm 1: Alarm
Running	Running
During Regenerative Operation	During Regenerative Operation
Ready	Ready 0: Not Ready 1: Ready
NetCtrl	Run command is from network 0: Run command is not from network 1: Run command is from network

Name	Description
NetRef	Voltage command is from network 0: Voltage command is not from network 1: Voltage command is from network
State	Contains the value from the Control Supervisor (Class 0x29) Instance 1 Attribute 6.
Voltage Actual	Actual Converter Voltage Monitors the converter output voltage. Speed actual data: Output Voltage x 2VS (VS: Voltage scale) Setting range: 0 - FFFF (Hex.) For example, when output voltage of 1024 with a voltage scale of 2: Voltage actual data = 1024 x 2 ² = 4096 = 1000 (Hex.)

◆ (Vendor Specific Yaskawa Electric (YE) Assy) Speed/Torque Status Input - 151 (0x97)

Input Instance	Word	Byte	Bit 7	Bit 6	Bit 5	Bit 4	Bit 3	Bit 2	Bit 1	Bit 0	
151	0	0	Faulted	Alarm	Ready	During Run - Operation Ready	Reset	During Regenerative Operation	-	Running	
		1	-	-	Multi-Function Digital Output 3	Multi-Function Digital Output 2	Multi-Function Digital Output 1	LOCAL/REMOTE	Uv	oPE	
	1	2	Output Voltage (Low Byte)								
		3	Output Voltage (High Byte)								
	2	4	-								
		5	-								
	3	6	D1000: Current Actual (Low Byte) R1000: -								
		7	D1000: Current Actual (High Byte) R1000: -								

Name	Description
Running	Running 0: Stop 1: Running
During Regenerative Operation	During Regenerative Operation 0: Converter not in regenerative operation 1: Converter in regenerative operation
Reset	Reset 0: - 1: Reset
During Run - Operation Ready	During Run - Operation Ready 0: Not Ready 1: Ready
Ready	Ready 0: Not Ready 1: Ready
Alarm	Alarm 0: No Alarm 1: Alarm
Faulted	Faulted 0: No Fault 1: Fault
oPE	oPE 0: - 1: oPExx
Uv	Undervoltage 0: - 1: Undervoltage
LOCAL/REMOTE	Run command is from network 0: Run command is not from network

11 Input Assemblies (Converter Produces)

Name	Description
	1: Run command is from network
Multi-Function Digital Output 1	Terminal M1/M2 (varies by converter model) 0: M1/M2 OFF 1: M1/M2 ON This function is enabled only when H2-01 is set to F. Note: The names of the digital outputs are different for different converter series.
Multi-Function Digital Output 2	Terminal M3/M4 (varies by converter model) 0: M3/M4 OFF 1: M3/M4 ON This function is enabled only when H2-02 is set to F. Note: The names of the digital outputs are different for different converter series.
Multi-Function Digital Output 3	Terminal M5/M6 (varies by converter model) 0: M5/M6 OFF 1: M5/M6 ON This function is enabled only when H2-03 is set to F. Note: The names of the digital outputs are different for different converter series.
Output Voltage	Converter Output Voltage
D1000: Current Actual R1000: -	D1000: Actual Output Current Monitors the converter output current. Unit: 0.1 A Unit is not affected by Current Scale CS. R1000: -

◆ (Vendor Specific Yaskawa Electric (YE) Assy) Extended Speed/Torque Status Input - 155 (0x9B)

Input Instance	Word	Byte	Bit 7	Bit 6	Bit 5	Bit 4	Bit 3	Bit 2	Bit 1	Bit 0	
155	0	0	Faulted	Alarm	Ready	During Run - Operation Ready	Reset	During Regenerative Operation	-	Running	
		1	-	-	Multi-Function Digital Output 3	Multi-Function Digital Output 2	Multi-Function Digital Output 1	LOCAL/REMOTE	Uv	oPE	
	1	2	Output Voltage (Low Byte)								
		3	Output Voltage (High Byte)								
	2	4	-								
		5	-								
	3	6	-								
		7	-								
	4	8	D1000: Voltage Command (Low Byte) R1000: -								
		9	D1000: Voltage Command (High Byte) R1000: -								
	5	10	Output Voltage (Low Byte)								
		11	Output Voltage (High Byte)								
	6	12	D1000: Output Current (Low Byte) R1000: -								
		13	D1000: Output Current (High Byte) R1000: -								
	7	14	Terminal A2 Input (Low Byte)								
		15	Terminal A2 Input (High Byte)								
	8	16	Main Circuit DC Voltage (Low Byte)								
		17	Main Circuit DC Voltage (High Byte)								
	9	18	Error Code (Low Byte)								

Input Instance	Word	Byte	Bit 7	Bit 6	Bit 5	Bit 4	Bit 3	Bit 2	Bit 1	Bit 0
	10	19	Error Code (High Byte)							
		20	Alarm Code 2 (Low Byte)							
	11	21	Alarm Code 2 (High Byte)							
		22	Alarm Code 3 (Low Byte)							
	12	23	Alarm Code 3 (High Byte)							
		24	Terminal A3 Input (Low Byte)							
	13	25	Terminal A3 Input (High Byte)							
		26	Digital Input (Low Byte)							
	14	27	Digital Input (High Byte)							
		28	Terminal A1 Input (Low Byte)							
	15	29	Terminal A1 Input (High Byte)							
		30	-							
	16 - 19	31	-							
		32 - 39	Reserved							

Name	Description
Running	Running 0: Stop 1: Running
During Regenerative Operation	During Regenerative Operation 0: Converter not in regenerative operation 1: Converter in regenerative operation
Reset	Reset 0: - 1: Reset
During Run - Operation Ready	0: Not Ready 1: Ready
Ready	Ready 0: Not Ready 1: Ready
Alarm	Alarm 0: No Alarm 1: Alarm
Faulted	Faulted 0: No Fault 1: Fault
oPE	oPE 0: - 1: oPExx
Uv	Undervoltage 0: - 1: Undervoltage
LOCAL/REMOTE	Run command is from network 0: Run command is not from network 1: Run command is from network
Multi-Function Digital Output 1	Terminal M1/M2 (varies by converter model) 0: M1/M2 OFF 1: M1/M2 ON This function is enabled only when H2-01 is set to F. Note: The names of the digital outputs are different for different converter series.
Multi-Function Digital Output 2	Terminal M3/M4 (varies by converter model) 0: M3/M4 OFF 1: M3/M4 ON This function is enabled only when H2-02 is set to F. Note: The names of the digital outputs are different for different converter series.
Multi-Function Digital Output 3	Terminal M5/M6 (varies by converter model)

11 Input Assemblies (Converter Produces)

Name	Description
	0: M5/M6 OFF 1: M5/M6 ON This function is enabled only when H2-03 is set to F. Note: The names of the digital outputs are different for different converter series.
Output Voltage	Converter Output Voltage
D1000: Voltage Command R1000: -	D1000: Converter Voltage Command R1000: -
D1000: Output Current R1000: -	D1000: Actual Output Current Monitors the converter output current. Unit: 0.01A Unit is not affected by Current Scale CS. R1000: -
Terminal A1 Input	MEMOBUS/Modbus (0x46) Monitor parameter U1-13
Terminal A2 Input	MEMOBUS/Modbus (0x4F) Monitor parameter U1-14
Terminal A3 Input	MEMOBUS/Modbus (0x50) Monitor parameter U1-15
Main Circuit DC Voltage	Main Circuit DC Voltage Monitor parameter U1-07
Error Code	U2-01 converted using fault code table.
Alarm Code 2	U2-01 converted using fault code table.
Alarm Code 3	U2-01 converted using fault code table.
Digital Inputs	Sets digital inputs 9-12 if the drive supports them.

◆ (Vendor Specific Yaskawa Electric (YE) Assy) High Speed/Torque Status Input - 166 (0xA6)

If an error occurs while trying to read from the dynamic parameters, the appropriate error bit in Assembly 166 will be set. If more information about the nature of the error is needed, the extended error status can be read explicitly through Class 4, Instance 0xA6, Attribute 0x64. This will return 20 Bytes with each dynamic parameter in Assembly 166 having a Byte dedicated to its extended error status.

*1 Selectable with F7-33 to F7-42.

Input Instance	Word	Byte	Bit 7	Bit 6	Bit 5	Bit 4	Bit 3	Bit 2	Bit 1	Bit 0	
166	0	0	Faulted	Alarm	Ready	During Run - Operation Ready	Reset	During Regenerative Operation	-	Running	
		1	-	-	Multi-Function Digital Output 3	Multi-Function Digital Output 2	Multi-Function Digital Output 1	LOCAL/REMOTE	Uv	oPE	
	1	2	Output Voltage (Low Byte)								
		3	Output Voltage (High Byte)								
	2	4	-								
		5	-								
	3	6	-								
		7	-								
	4	8	D1000: Voltage Command (Low Byte) R1000: -								
		9	D1000: Voltage Command (High Byte) R1000: -								
	5	10	Output Voltage (Low Byte)								
		11	Output Voltage (High Byte)								
	6	12	D1000: Output Current (Low Byte) R1000: -								
		13	D1000: Output Current (High Byte)								

Input Instance	Word	Byte	Bit 7	Bit 6	Bit 5	Bit 4	Bit 3	Bit 2	Bit 1	Bit 0
			R1000: -							
7	14	Terminal A1 Input (Low Byte)								
		15	Terminal A1 Input (High Byte)							
8	16		Main Circuit DC Voltage (Low Byte)							
		17	Main Circuit DC Voltage (High Byte)							
9	18		Error Code (Low Byte)							
		19	Error Code (High Byte)							
10	20 - 21		Parameter [F7-33], Default: Alarm Code							
11	22 - 23	D1000: Parameter [F7-34], Default: Output Power R1000: Parameter [F7-34], Default: Not Used								
12	24 - 25	Parameter [F7-35], Default: Terminal A2 Input								
13	26 - 27	Parameter [F7-36], Default: Terminal S1 - S8 Input								
14	28 - 29	Parameter [F7-37], Default: Terminal A3 Input								
15	30 - 31	Parameter [F7-38], Default: Not Used								
16	32	-	-	-	-	-	-	-	Parameter [F7-39] (Low Byte), Default: NetCtrl	Parameter [F7-39] (Low Byte), Default: NetRef
		33	Parameter [F7-39] (High Byte), Default: Not Used							
17	34 - 35	Parameter [F7-40], Default: Converter Software Version								
18	36 - 37	Parameter [F7-41], Default: Not Used								
19	38 - 39	Parameter [F7-42], Default: Not Used								
20	40	-	-	-	-	-	-	-	Assy. 116 F7-32 Error	Assy. 116 F7-31 Error
		41	Assy. 116 F7-30 Error	Assy. 116 F7-29 Error	Assy. 116 F7-28 Error	Assy. 116 F7-27 Error	Assy. 116 F7-26 Error	Assy. 116 F7-25 Error	Assy. 116 F7-24 Error	Assy. 116 F7-23 Error
21	42	-	-	-	-	-	-	-	Assy. 166 F7-42 Error	Assy. 166 F7-41 Error
		43	Assy. 166 F7-40 Error	Assy. 166 F7-39 Error	Assy. 166 F7-38 Error	Assy. 166 F7-37 Error	Assy. 166 F7-36 Error	Assy. 166 F7-35 Error	Assy. 166 F7-34 Error	Assy. 166 F7-33 Error

Name	Description
Running	Running 0: Stop 1: Running
During Regenerative Operation	During Regenerative Operation 0: Converter not in regenerative operation 1: Converter in regenerative operation
Reset	Reset 0: - 1: Reset
During Run - Operation Ready	During Run - Operation Ready 0: Not Ready 1: Ready
Ready	Ready 0: Not Ready 1: Ready
Alarm	Alarm 0: No Alarm 1: Alarm
Faulted	Faulted 0: No Fault 1: Fault
oPE	oPE 0: - 1: oPExx
Uv	Undervoltage

11 Input Assemblies (Converter Produces)

Name	Description
	0: - 1: Undervoltage
LOCAL/REMOTE	Run command is from network 0: Run command is not from network 1: Run command is from network
Multi-Function Digital Output 1	Terminal M1/M2 (varies by converter model) 0: M1/M2 OFF 1: M1/M2 ON This function is enabled only when H2-01 is set to F. Note: The names of the digital outputs are different for different converter series.
Multi-Function Digital Output 2	Terminal M3/M4 (varies by converter model) 0: M3/M4 OFF 1: M3/M4 ON This function is enabled only when H2-02 is set to F. Note: The names of the digital outputs are different for different converter series.
Multi-Function Digital Output 3	Terminal M5/M6 (varies by converter model) 0: M5/M6 OFF 1: M5/M6 ON This function is enabled only when H2-03 is set to F. Note: The names of the digital outputs are different for different converter series.
Output Voltage	Converter Output Voltage
Voltage Command	Converter Voltage Command
D1000: Output Current R1000: -	D1000: Actual Output Current Monitors the converter output current. Unit: 0.01A Unit is not affected by Current Scale CS. R1000: -
Terminal A1 Input	MEMOBUS/Modbus (0x46) Monitor parameter U1-13
Main Circuit DC Voltage	Main Circuit DC Voltage Monitor parameter U1-07
Error Code	U2-01 converted using fault code table.
F7-33 Alarm Code	Programmable: MEMOBUS/Modbus (0x7F)
D1000: F7-34 Output Power R1000: F7-34 Not Used	D1000: Programmable: MEMOBUS/Modbus (0x47) Monitor parameter U1-08 R1000: -
F7-35 Terminal A2 Input	Programmable: MEMOBUS/Modbus (0x4F) Monitor parameter U1-14
F7-36 Terminal S1 - S12	Programmable: MEMOBUS/Modbus (0x49) Monitor parameter U1-10
F7-37 Terminal A3 Input	Programmable: MEMOBUS/Modbus (0x50)
F7-38 Not Used	-
F7-39 NetRef (Status)	Voltage command is from network 0: Voltage command is not from network 1: Voltage command is from network
F7-39 Not Used	-
F7-40 Converter Software Version	Programmable: MEMOBUS/Modbus (0x4D) Monitor parameter U1-25
F7-41 Not Used	-
F7-42 Not Used	-

Possible extended error codes are listed in [Table 11.1](#) and [Table 11.2](#). If an error occurs, extended error code 0x02 (Register number failure) is usually set.

Table 11.1 Extended Error Codes for Assembly 116/166

Error Code	Description
0x00	No Fault
0x01	Sub function code failure
0x02	Register Number
0x21	Limit check error failure
0x22	Write Failure
0x23	Write failure at Uv
0x24	Write failure at busy

Table 11.2 Extended Error Codes in Class 0x04 Instance 0xA6 Attribute 0x64

Dynamic Parameter	Byte Containing Extended Error Code
F7-23	Byte 0
F7-24	Byte 1
F7-25	Byte 2
F7-26	Byte 3
F7-27	Byte 4
F7-28	Byte 5
F7-29	Byte 6
F7-30	Byte 7
F7-31	Byte 8
F7-32	Byte 9
F7-33	Byte 10
F7-34	Byte 11
F7-35	Byte 12
F7-36	Byte 13
F7-37	Byte 14
F7-38	Byte 15
F7-39	Byte 16
F7-40	Byte 17
F7-41	Byte 18
F7-42	Byte 19

◆ (Vendor Specific Yaskawa Electric (YE) Assy) 8-Byte Dynamic Input 2 - 167 (0xA7)

Input Instance	Word	Byte	Bit 7	Bit 6	Bit 5	Bit 4	Bit 3	Bit 2	Bit 1	Bit 0	
167	0	0	Faulted	Alarm	Ready	During Run - Operation Ready	Reset	During Regenerative Operation	-	Running	
		1	-	-	Multi-Function Digital Output 3	Multi-Function Digital Output 2	Multi-Function Digital Output 1	LOCAL/REMOTE	Uv	oPE	
	1	2	Output Voltage (Low Byte)								
		3	Output Voltage (High Byte)								
	2	4 - 5	Parameter [F7-33], Default: Alarm Code								
	3	6 - 7	D1000: Parameter [F7-34], Default: Output Power R1000: Parameter [F7-34], Default: Not Used								

11 Input Assemblies (Converter Produces)

Name	Description
Running	Running 0: Stop 1: Running
During Regenerative Operation	During Regenerative Operation 0: Converter not in regenerative operation 1: Converter in regenerative operation
Reset	Reset 0: - 1: Reset
During Run - Operation Ready	During Run - Operation Ready 0: Not Ready 1: Ready
Ready	Ready 0: Not Ready 1: Ready
Alarm	Alarm 0: No Alarm 1: Alarm
Faulted	Faulted 0: No Fault 1: Fault
oPE	oPE 0: - 1: oPExx
Uv	Undervoltage 0: - 1: Undervoltage
LOCAL/REMOTE	Run command is from network 0: Run command is not from network 1: Run command is from network
Multi-Function Digital Output 1	Terminal M1/M2 (varies by converter model) 0: M1/M2 OFF 1: M1/M2 ON This function is enabled only when H2-01 is set to F. Note: The names of the digital outputs are different for different converter series.
Multi-Function Digital Output 2	Terminal M3/M4 (varies by converter model) 0: M3/M4 OFF 1: M3/M4 ON This function is enabled only when H2-02 is set to F. Note: The names of the digital outputs are different for different converter series.
Multi-Function Digital Output 3	Terminal M5/M6 (varies by converter model) 0: M5/M6 OFF 1: M5/M6 ON This function is enabled only when H2-03 is set to F. Note: The names of the digital outputs are different for different converter series.
Output Voltage	Converter Output Voltage
F7-33 Alarm Code	Programmable: MEMOBUS/Modbus (0x7F)
D1000: F7-34 Output Power R1000: F7-34 Not Used	D1000: Programmable: MEMOBUS/Modbus (0x47) Monitor parameter U1-08 R1000: -

◆ (Vendor Specific Yaskawa Electric (YE) Assy) 12-Byte Dynamic Input 4 - 168 (0xA8)

Input Instance	Word	Byte	Bit 7	Bit 6	Bit 5	Bit 4	Bit 3	Bit 2	Bit 1	Bit 0
168	0	0	Faulted	Alarm	Ready	During Run - Operation Ready	Reset	During Regenerative Operation	-	Running
		1	-	-	Multi-Function	Multi-Function	Multi-Function	LOCAL/REMOTE	Uv	oPE

Input Instance	Word	Byte	Bit 7	Bit 6	Bit 5	Bit 4	Bit 3	Bit 2	Bit 1	Bit 0
					Digital Output 3	Digital Output 2	Digital Output 1			
1	2	Output Voltage (Low Byte)								
		3	Output Voltage (High Byte)							
2	4 - 5		Parameter [F7-33], Default: Alarm Code							
3	6 - 7		D1000: Parameter [F7-34], Default: Output Power R1000: Parameter [F7-34], Default: Not Used							
4	8 - 9		Parameter [F7-35], Default: Terminal A2 Input							
5	10 - 11		Parameter [F7-36], Default: Terminal S1 - S8 Input							

Name	Description
Running	Running 0: Stop 1: Running
During Regenerative Operation	During Regenerative Operation 0: Converter not in regenerative operation 1: Converter in regenerative operation
Reset	Reset 0: - 1: Reset
During Run - Operation Ready	During Run - Operation Ready 0: Not Ready 1: Ready
Ready	Ready 0: Not Ready 1: Ready
Alarm	Alarm 0: No Alarm 1: Alarm
Faulted	Faulted 0: No Fault 1: Fault
oPE	oPE 0: - 1: oPExx
Uv	Undervoltage 0: - 1: Undervoltage
LOCAL/REMOTE	Run command is from network 0: Run command is not from network 1: Run command is from network
Multi-Function Digital Output 1	Terminal M1/M2 (varies by converter model) 0: M1/M2 OFF 1: M1/M2 ON This function is enabled only when H2-01 is set to F. Note: The names of the digital outputs are different for different converter series.
Multi-Function Digital Output 2	Terminal M3/M4 (varies by converter model) 0: M3/M4 OFF 1: M3/M4 ON This function is enabled only when H2-02 is set to F. Note: The names of the digital outputs are different for different converter series.
Multi-Function Digital Output 3	Terminal M5/M6 (varies by converter model) 0: M5/M6 OFF 1: M5/M6 ON This function is enabled only when H2-03 is set to F. Note: The names of the digital outputs are different for different converter series.
Output Voltage	Converter Output Voltage
F7-33 Alarm Code	Programmable: MEMOBUS/Modbus (0x7F)

11 Input Assemblies (Converter Produces)

Name	Description
D1000: F7-34 Output Power R1000: F7-34 Not Used	D1000: Programmable: MEMOBUS/Modbus (0x47) Monitor parameter U1-08 R1000: -
F7-35 Terminal A2 Input	Programmable: MEMOBUS/Modbus (0x4F) Monitor parameter U1-14
F7-36 Terminal S1 - S12	Programmable: MEMOBUS/Modbus (0x49) Monitor parameter U1-10

◆ (Vendor Specific Yaskawa Electric (YE) Assy) 18-Byte Dynamic Input 7 - 169 (0xA9)

Input Instance	Word	Byte	Bit 7	Bit 6	Bit 5	Bit 4	Bit 3	Bit 2	Bit 1	Bit 0	
169	0	0	Faulted	Alarm	Ready	During Run - Operation Ready	Reset	During Regenerative Operation	-	Running	
		1	-	-	Multi-Function Digital Output 3	Multi-Function Digital Output 2	Multi-Function Digital Output 1	LOCAL/REMOTE	Uv	oPE	
	1	2	Output Voltage (Low Byte)								
		3	Output Voltage (High Byte)								
	2	4 - 5	Parameter [F7-33], Default: Alarm Code								
	3	6 - 7	D1000: Parameter [F7-34], Default: Output Power R1000: Parameter [F7-34], Default: Not Used								
	4	8 - 9	Parameter [F7-35], Default: Terminal A2 Input								
	5	10 - 11	Parameter [F7-36], Default: Terminal S1 - S8 Input								
	6	12 - 13	Parameter [F7-37], Default: Terminal A3 Input								
	7	14 - 15	Parameter [F7-38], Default: Not Used								
	8	16	-	-	-	-	-	-	-	Parameter [F7-39] (Low Byte), Default: Net Ctrl	Parameter [F7-39] (Low Byte), Default: Net Ref
		17	Parameter [F7-39] (High Byte), Default: Not Used								

Name	Description
Running	Running 0: Stop 1: Running
During Regenerative Operation	During Regenerative Operation 0: Converter not in regenerative operation 1: Converter in regenerative operation
Reset	Reset 0: - 1: Reset
During Run - Operation Ready	During Run - Operation Ready 0: Not Ready 1: Ready
Ready	Ready 0: Not Ready 1: Ready
Alarm	Alarm 0: No Alarm 1: Alarm
Faulted	Faulted 0: No Fault 1: Fault
oPE	oPE 0: - 1: oPExx
Uv	Undervoltage

Name	Description
	0: - 1: Undervoltage
LOCAL/REMOTE	Run command is from network 0: Run command is not from network 1: Run command is from network
Multi-Function Digital Output 1	Terminal M1/M2 (varies by converter model) 0: M1/M2 OFF 1: M1/M2 ON This function is enabled only when H2-01 is set to F. Note: The names of the digital outputs are different for different converter series.
Multi-Function Digital Output 2	Terminal M3/M4 (varies by converter model) 0: M3/M4 OFF 1: M3/M4 ON This function is enabled only when H2-02 is set to F. Note: The names of the digital outputs are different for different converter series.
Multi-Function Digital Output 3	Terminal M5/M6 (varies by converter model) 0: M5/M6 OFF 1: M5/M6 ON This function is enabled only when H2-03 is set to F. Note: The names of the digital outputs are different for different converter series.
Output Voltage	Converter Output Voltage
F7-33 Alarm Code	Programmable: MEMOBUS/Modbus (0x7F)
D1000: F7-34 Output Power R1000: F7-34 Not Used	D1000: Programmable: MEMOBUS/Modbus (0x47) Monitor parameter U1-08 R1000: -
F7-35 Terminal A2 Input	Programmable: MEMOBUS/Modbus (0x4F) Monitor parameter U1-14
F7-36 Terminal S1 - S12	Programmable: MEMOBUS/Modbus (0x49) Monitor parameter U1-10
F7-37 Terminal A3 Input	Programmable: MEMOBUS/Modbus (0x50)
F7-38 Not Used	-
F7-39 NetRef (Status)	Voltage command is from network 0: Voltage command is not from network 1: Voltage command is from network
F7-39 NetCtrl	Run command is from network 0: Run command is not from network 1: Run command is from network
F7-39 Not Used	-

◆ (Vendor Specific Yaskawa Electric (YE) Assy) 24-Byte Dynamic Input 10 - 170 (0xAA)

Input Instance	Word	Byte	Bit 7	Bit 6	Bit 5	Bit 4	Bit 3	Bit 2	Bit 1	Bit 0	
170	0	0	Faulted	Alarm	Ready	During Run - Operation Ready	Reset	During Regenerative Operation	-	Running	
		1	-	-	Multi-Function Digital Output 3	Multi-Function Digital Output 2	Multi-Function Digital Output 1	LOCAL/REMOTE	Uv	oPE	
	1	2	Output Voltage (Low Byte)								
		3	Output Voltage (High Byte)								
	2	4 - 5	Parameter [F7-33], Default: Alarm Code								
	3	6 - 7	D1000: Parameter [F7-34], Default: Output Power R1000: Parameter [F7-34], Default: Not Used								
	4	8 - 9	Parameter [F7-35], Default: Terminal A2 Input								
	5	10 - 11	Parameter [F7-36], Default: Terminal S1 - S8 Input								

11 Input Assemblies (Converter Produces)

Input Instance	Word	Byte	Bit 7	Bit 6	Bit 5	Bit 4	Bit 3	Bit 2	Bit 1	Bit 0	
	6	12 - 13	Parameter [F7-37], Default: Terminal A3 Input								
	7	14 - 15	Parameter [F7-38], Default: Not Used								
	8	16	-	-	-	-	-	-	-	Parameter [F7-39] (Low Byte), Default: Net Ctrl	Parameter [F7-39] (Low Byte), Default: Net Ref
			17	Parameter [F7-39], Default: Not Used (High Byte)							
	9	18 - 19	Parameter [F7-40], Default: Converter Software Version								
	10	20 - 21	Parameter [F7-41], Default: Not Used								
	11	22 - 23	Parameter [F7-42], Default: Not Used								

Name	Description
Running	Running 0: Stop 1: Running
During Regenerative Operation	During Regenerative Operation 0: Converter not in regenerative operation 1: Converter in regenerative operation
Reset	Reset 0: - 1: Reset
During Run - Operation Ready	During Run - Operation Ready 0: Not Ready 1: Ready
Ready	Ready 0: Not Ready 1: Ready
Alarm	Alarm 0: No Alarm 1: Alarm
Faulted	Faulted 0: No Fault 1: Fault
oPE	oPE 0: - 1: oPExx
Uv	Undervoltage 0: - 1: Undervoltage
LOCAL/REMOTE	Run command is from network 0: Run command is not from network 1: Run command is from network
Multi-Function Digital Output 1	Terminal M1/M2 (varies by converter model) 0: M1/M2 OFF 1: M1/M2 ON This function is enabled only when H2-01 is set to F. Note: The names of the digital outputs are different for different converter series.
Multi-Function Digital Output 2	Terminal M3/M4 (varies by converter model) 0: M3/M4 OFF 1: M3/M4 ON This function is enabled only when H2-02 is set to F. Note: The names of the digital outputs are different for different converter series.
Multi-Function Digital Output 3	Terminal M5/M6 (varies by converter model) 0: M5/M6 OFF 1: M5/M6 ON This function is enabled only when H2-03 is set to F. Note: The names of the digital outputs are different for different converter series.
Output Voltage	Converter Output Voltage

Name	Description
F7-33 Alarm Code	Programmable: MEMOBUS/Modbus (0x7F)
D1000: F7-34 Output Power R1000: F7-34 Not Used	D1000: Programmable: MEMOBUS/Modbus (0x47) Monitor parameter U1-08 R1000: -
F7-35 Terminal A2 Input	Programmable: MEMOBUS/Modbus (0x4F) Monitor parameter U1-14
F7-36 Terminal S1 - S12	Programmable: MEMOBUS/Modbus (0x49) Monitor parameter U1-10
F7-37 Terminal A3 Input	Programmable: MEMOBUS/Modbus (0x50)
F7-38 Not Used	-
F7-39 NetRef (Status)	Voltage command is from network 0: Voltage command is not from network 1: Voltage command is from network
F7-39 NetCtrl	Run command is from network 0: Run command is not from network 1: Run command is from network
F7-39 Not Used	-
F7-40 Converter Software Version	Programmable: MEMOBUS/Modbus (0x4D) Monitor parameter U1-25
F7-41 Not Used	-
F7-42 Not Used	-

12 General Class Objects (Drive)

◆ Identity Object - 1 (Class 0x01)

■ Services Supported

Service Code No. (hex)	Service Name
01	Get Attribute All
05	Reset
0E	Get Attribute Single

■ Attributes Supported

Instance ID	Attribute	Name	Description	Get	Set	Size	Range	Default
0	1	Object Software Revision	Identity Object software revision	○	-	Word	-	1
1	1	Vendor ID	Manufacturer code. 44 (2C (Hex.)): Yaskawa Electric	○	-	Word	-	44
1	2	Device Type	Device profile. The profile for this product is an AC drive. 2: AC drive	○	-	Word	-	2
1	3	Product Code	Product codes determined by the manufacturer.	○	-	Word	-	*1
1	4	Revision	Software revision for the option.	○	-	Word	-	Depends on software
1	5	Status	Shows the communication status for the drive.	○	-	Word	-	0
1	6	Serial number	Option serial number.	○	-	Long	-	Each unit is unique
1	7	Product Name	Product Name	○	-	String	-	Product dependent (i.e., CIMR-AA2A0004)
1	8	State	Operation status of the drive. 3: Drive ready 4: Fault	○	-	Byte	-	3

Instance ID	Attribute	Name	Description	Get	Set	Size	Range	Default
								00 00 00 00 00 00 00 00 00
167	3	Data	Same function as the 8 Byte Dynamic Input (Input Assembly)	○	-	Array 8 Bytes	-	00 00 00 00 00 00 00 00 00
168	3	Data	Same function as the 12 Byte Dynamic Input (Input Assembly)	○	-	Array 12 Bytes	-	00 00 00 00 00 00 00 00 00 00 00 00
169	3	Data	Same function as the 18 Byte Dynamic Input (Input Assembly)	○	-	Array 18 Bytes	-	00 00 00 00 00 00 00 00 00 00 00 00 00 00 00 00 00 00 00
170	3	Data	Same function as the 24 Byte Dynamic Input (Input Assembly)	○	-	Array 24 Bytes	-	00 00

◆ Motor Data Object - 40 (Class 0x28)

Note:

This object is not available in D1000 and R1000. Refer to [Motor Data Object - 40 \(Class 0x28\) on page 106](#) for more information about this object compatible with D1000 and R1000.

■ Services Supported

Service Code No. (hex)	Service Name
0E	Get Attribute Single
10	Set Attribute Single

■ Attributes Supported

Instance ID	Attribute	Name	Description	Get	Set	Size	Range	Default
0	1	Object Software Revision	Motor Data Object software revision.	○	-	Word	-	1
1	3	Motor Type	Type of motor used. 3: PM motor 7: IM Motor The setting value of this parameter is different for different A1-02 [Control Method Selection] setting. When A1-02 = 5, 6, 7 [PM Open Loop Vector, PM Advanced Open Loop Vector, PM Closed Loop Vector], value becomes 3 [PM Motor]. When A1-02 = 0, 1, 2, 3 [V/f Control, V/f Control with Encoder, Open Loop Vector, Closed Loop Vector], value becomes 7 [IM Motor]. Note: On GA700, GA800, HV600, and FP605 when A1-02 = 8 [EZ Vector Control], this looks at E9-01 (E9-01 = 0 value becomes 7, E9-01 = 1 value becomes 3).	○	-	Byte	-	Depends on A1-02 [Control Method Selection].
1	6	Rated Current [0.1 A]	Motor rated current (E2-01). Displayed in 0.1 A units. Changes according to the current scale (CS).	○	○	Byte	-	Depends on capacity
1	7	Rated Voltage [1 V]	Motor rated voltage (E1-01). Displayed in 1 V units. Changes according to the voltage scale (VS).	○	○	Byte	-	Depends on capacity

◆ Control Supervisor Object - 41 (Class 0x29)

Note:

This information applies to all products except D1000/R1000 converters. For the D1000/R1000 data for this object, refer to [Control Supervisor Object 41 \(Class 0x29\) on page 106](#).

■ Services Supported

Service Code No. (hex)	Service Name
0E	Get Attribute Single
10	Set Attribute Single
05	Reset

■ Attributes Supported

Instance ID	Attribute	Name	Description	Get	Set	Size	Range	Default
0	1	Object Software Revision	Revision number of the Control Supervisor Object.	○	-	Word	-	1
1	3	Run command 1 (FWD)	Forward Run Command 0: Stop 1: Forward Run	○	○	Byte	0, 1	0
1	4	Run command 2 (REV)	Reverse Run Command 0: Stop 1: Reverse Run	○	○	Byte	0, 1	0
1	5	NetCtrl (Command)	Run command is from network 0: Depends on b1-02 1: Run command is from network	○	○	Byte	0, 1	0
1	6	State	State 2: Not Ready 3: Ready (Stopped) 4: Enabled (Run command present) 5: Deceleration to Stop 6: Fault Stop 7: Fault	○	-	Byte	-	3
1	7	Running 1 (FWD)	Forward Running 0: Stop or Reverse Running 1: Forward Running	○	-	Byte	-	0
1	8	Running 2 (REV)	Reverse Running 0: Stop or Forward Running 1: Reverse Running	○	-	Byte	-	0
1	9	Ready	Ready 0: Not Ready 1: Ready	○	-	Byte	-	1
1	10	Faulted	Faulted 0: No Fault 1: Fault	○	-	Byte	-	0
1	11	Alarm	Alarm 0: No Alarm 1: Alarm	○	-	Byte	-	0
1	12	Fault Reset	Fault Reset 0: - 1: Fault Reset	○	○	Byte	0, 1	0
1	13	Fault Code	Current Fault Refer to page 97 for more information.	○	-	Word	-	0000
1	15	NetCtrl (Status)	Run command is from network 0: Run command is not from network 1: Run command is from network	○	-	Byte	-	0
1	16	EtherNet/IP Fault Mode	Normal 2 (Vendor Specific)	○	-	Byte	-	2
1	17	Force Fault	External Fault 0: - 1: External Fault [EF0] Triggered by the rising edge of the signal.	○	○	Byte	0, 1	0

Instance ID	Attribute	Name	Description	Get	Set	Size	Range	Default
1	18	Force Reset	External Fault status 0: - 1: External Fault [EF0] Triggered by the rising edge of the signal.	○	-	Byte	-	0
1	20	Net Idle Mode	Operation mode selection when communication is in Idle Mode. 0: Stop 1: Ignore 2: Stop if F6-01 is set to fault mode. 3: Forward Run 4: Reverse Run Note: Available in option software versions PRG: 0345 and later.	○	○	-	0 - 4	

■ Option Fault Code Conversion Table

Drive Fault Code (Dec.) (MEMOBUS/Modbus 0080 (Hex.))	Option Fault Code (Hex.)	Description
0	0000	Normal
2	3220	Uv1 [DC Bus Undervoltage]
3	5110	Uv2 [Control Power Undervoltage]
4	3222	Uv3 [Soft Charge Answerback Fault]
6	2120	GF [Ground Fault]
7	2300	oC [Overcurrent]
8	3210	ov [Overvoltage]
9	4200	oH [Heatsink Overheat]
10	4210	oH1 [Heatsink Overheat]
11	2220	oL1 [Motor Overload]
12	2200	oL2 [Drive Overload]
13	2221	oL3 [Overtorque Detection 1]
14	2222	oL4 [Overtorque Detection 2]
15	7110	rr [Dynamic Braking Transistor Fault]
16	7112	rH [Braking Resistor Overheat]
17	9000	EF3 [External Fault (Terminal S3)]
18	9000	EF4 [External Fault (Terminal S4)]
19	9000	EF5 [External Fault (Terminal S5)]
20	9000	EF6 [External Fault (Terminal S6)]
21	9000	EF7 [External Fault (Terminal S7)]
22	9000	EF8 [External Fault (Terminal S8)]
24	7310	oS [Overspeed]
25	7310	dEv [Speed Deviation]
26	7301	PGo [Encoder (PG) Feedback Loss]
27	3130	PF [Input Phase Loss]
28	3130	LF [Output Phase Loss]
29	5210	oH3 [Motor Overheat (PTC Input)]
30	5300	oPr [Keypad Connection Fault]
31	6320	Err [EEPROM Write Error]
32	0	oH4 [Motor Overheat Fault (PTC Input)]
33	7500	CE [Modbus Communication Error]
34	7500	bUS [Option Communication Error]
37	8321	CF [Control Fault]

12 General Class Objects (Drive)

Drive Fault Code (Dec.) (MEMOBUS/Modbus 0080 (Hex.))	Option Fault Code (Hex.)	Description
38	8313	SvE [Zero Servo Fault]
39	9000	EF0 [Option Card External Fault]
40	8000	FbL [PID Feedback Loss]
41	8000	UL3 [Undertorque Detection 1]
42	8000	UL4 [Undertorque Detection 2]
43	8000	oL7 [High Slip Braking Overload]
50	8000	dv1 [Z Pulse Fault]
51	8000	dv2 [Z Pulse Noise Fault Detection]
52	8000	dv3 [Inversion Detection]
53	8000	dv4 [Inversion Prevention Detection]
54	8000	LF2 [Output Current Imbalance]
55	8000	STo [Pull-Out Detection] Note: When using YASKAWA AC Drive GA500, GA700, GA800, HV600, or FP605, STPo [Motor Step-Out Detected] will be shown.
56	7000	PGoH [Encoder (PG) Hardware Fault]
59	1000	SEr [Speed Search Retries Exceeded]
65	8000	FbH [Excessive PID Feedback]
66	9000	EF1 [External Fault (Terminal S1)]
67	9000	EF2 [External Fault (Terminal S2)]
68	8000	oL5 [Mechanical Weakening Detection 1]
69	8000	UL5 [Mechanical Weakening Detection 2]
70	5000	CoF [Current Offset Fault]
73	8000	dWFL [DriveWorksEZ Fault]
77	5000	voF [Output Voltage Detection Fault]
78	7000	rF [Braking Resistor Fault]
79	7000	boL [Braking Transistor Overload Fault]
-	1000	Other faults

◆ AC/DC Drive Object - 42 (Class 0x2A)

Note:

This object is not available in D1000 and R1000. Refer to *AC/DC Drive Object - 42 (Class 0x2A) on page 107* for more information about this object compatible with D1000 and R1000.

■ Services Supported

Service Code No. (hex)	Service Name
0E	Get Attribute Single
10	Set Attribute Single

■ Attributes Supported

Instance ID	Attribute	Name	Description	Get	Set	Size	Range	Default
0	1	Object Software Revision	Revision number of AC/DC drive object	○	-	Word	-	1
1	3	Speed Agree	Speed Agree 0: - 1: Speed actual at speed reference	○	-	Byte	-	0
1	4	NetRef (Command)	Speed reference is from network 0: Speed reference is not from network 1: Speed reference is from network	○	-	Byte	-	0

Instance ID	Attribute	Name	Description	Get	Set	Size	Range	Default
1	6	Drive Mode	Drive Control Mode 0: OLV 0: OLV for PM (Read only) 0: Advanced OLV for PM (Read only) 1: V/f 2: V/f with PG 3: CLV 3: CLV for PM (Read only) Note: On GA500, GA700, GA800, HV600, and FP605, setting 1 also includes EZOLV (Read only). 1: V/f Control, EZ Vector Control	○	○	Byte	0 - 3	0
1	7	Speed Actual	Actual Drive Speed Unit depends on o1-03.	○	-	Word	-	3
1	8	Speed Reference	Speed Reference Unit depends on o1-03.	○	○	Word	-	0
1	9	Current Actual	Actual Output Current Monitors drive output current. Unit is 0.01 A for drives set up to 11 kW in Heavy Duty or Normal Duty and 0.1 A for drives set up for 15 kW and above. The maximum applicable motor output varies depending on the setting of C6-01 [Normal / Heavy Duty Selection].	○	-	Word	-	0
1	11	Torque Actual	Drive Output Torque Unit is affected by Torque Scale (TS)	○	-	Word	-	0
1	12	Torque Reference/Torque Limit	Torque Reference/Torque Limit Sets the Torque Reference/Torque Limit. Unit is affected by Torque Scale (TS) Sets the Torque Reference when using Torque Control [d5-01 = 1]. Sets the Torque Limit when using Speed Control [d5-01 = 0]. The Torque Reference/Torque Limit are disabled when F6-06 = 0.	○	○	Word	-	0
1	15	Power Actual [W]	Drive Output Power Unit is affected by Power Scale (PS).	○	-	Word	-	0
1	16	Input Voltage [V]	Drive Input Voltage [E1-01] Unit is affected by Voltage Scale (VS).	○	-	Word	-	Depends on capacity
1	17	Output Voltage [V]	Drive Output Voltage Unit is affected by Voltage Scale (VS).	○	-	Word	-	0
1	18	Accel Time [ms]	Acceleration Time 1 [C1-01] Units set in parameter C1-10. Unit is affected by Time Scale (TS).	○	○	Word	-	2710 (Hex.)
1	19	Decel Time [ms]	Acceleration Time 1 [C1-02] Units set in parameter C1-10. Unit is affected by Time Scale (TS).	○	○	Word	-	2710 (Hex.)
1	20	Low Speed Limit Percent of Max Speed	Frequency Reference Lower Limit [d2-02]	○	○	Word	0 - 1100	0
1	21	High Speed Limit Percent of Max Speed	Frequency Reference Upper Limit [d2-01]	○	○	Word	0 - 1100	3E8 (Hex.)
1	22	Speed Scale (-15 - +15)	Scale of Units for Speed Related Data Sets or verifies F7-17 [EtherNet/IP Speed Scaling Factor].	○	○	Byte	-15 - +15	0
1	23	Current Scale (-15 - +15)	Scale of Units for Current Related Data Sets or verifies F7-18 [EtherNet/IP Current Scale Factor].	○	○	Byte	-15 - +15	0
1	24	Torque Scale (-15 - +15)	Scale of Units for Torque Related Data	○	○	Byte	-15 - +15	0

Instance ID	Attribute	Name	Description	Get	Set	Size	Range	Default
			Sets or verifies F7-19 [EtherNet/IP Torque Scale Factor].					
1	26	Power Scale (-15 - +15)	Scale of Units for Power Related Data Sets or verifies F7-20 [EtherNet/IP Power Scaling Factor].	○	○	Byte	-15 - +15	0
1	27	Voltage Scale (-15 - +15)	Scale of Units for Voltage Related Data Sets or verifies F7-21 [EtherNet/IP Voltage Scale Factor].	○	○	Byte	-15 - +15	0
1	28	Time Scale (-15 - +15)	Scale of Units for Time Related Data Sets or verifies F7-22 [EtherNet/IP Time Scaling].	○	○	Byte	-15 - +15	0
1	29	NetRef (Status)	Speed reference is from network 0: Speed reference is not from network 1: Speed reference is from network	○	-	Byte	-	0

◆ DLR Object 71 (Class 0x47)

Device Level Ring (DLR) is a layer 2 protocol allowing for redundancy in EtherNet/IP based ring topology networks. DLR allows devices to be placed in a ring to reduce the need for switch hardware and cabling and allow for the detection and recovery of faults in the ring. This option is a beacon-based ring node implementation.

To set up a DLR network, configure a supervisor on the network prior to connecting and powering on all devices in the ring. Establishing a ring without an active supervisor may cause a loss of communication to devices on the ring.

The supervisor precedence must be configured when setting up the supervisor. Typically, the default beacon rate is 400 ms to allow for faster fault detection and recovery period and should be fast enough for devices to recover on the ring without losing an I/O connection. The precedence value for the supervisor is used when more than one supervisor is present. When two supervisors are on the network, the supervisor with the higher MAC address will become the supervisor and the other will become a backup supervisor.

Yaskawa recommends that all devices in the ring be DLR capable. Add non-DLR devices to the ring through a DLR-capable device, such as a 3-port ETAP.

Ensure that non-DLR devices placed in the ring meet the following requirements:

- Disable MAC address learning
- Do not use multicast filtering
- Preserve VLAN tags.

Make sure that all switches in the ring are DLR-aware. Switches in the ring that are not DLR-aware may cause undesired behavior due to MAC address learning of the supervisor beacon packets being received on two different switch ports.

Be sure to set the RPI only as fast as needed to limit the network traffic. This product supports RPIs down to 10 ms. However, if a slower level of control is acceptable, a slower RPI setting will reduce network traffic.

Yaskawa also recommends setting up and configuring all devices prior to completing the ring by leaving one cable disconnected. Make the last connection after configuring the nodes and supervisor.

Note:

DLR is supported in option software versions PRG: 0341 and later.

■ Services Supported

Service Code No. (hex)	Service Name
01	Get Attribute All
10	Set Attribute Single

■ Attributes Supported

Instance ID	Attribute	Name	Description	Get	Set	Size	Range	Default
0	1	Object Software Revision	Revision number of the DLR Object	○	-	Word	-	3
1	1	Network Topology	Current network topology mode	○	-	Byte	0, 1	0

Instance ID	Attribute	Name	Description	Get	Set	Size	Range	Default
			0: Linear 1: Ring					
1	2	Network Status	Current status of network 0: Normal 1: Ring fault 2: Unexpected loop detected 3: Partial network fault 4: Rapid fault/restore cycle	○	-	Byte	0 - 4	-
1	10	Active Supervisor Address	Struct of: Supervisor IP Address = Long Supervisor MAC Address = Array of bytes	○	-	Struct	-	-
1	12	Capability Flags	Describes DLR capabilities	○	-	Long	-	0x00000002

Note:

“Get Attribute All” Service shall report in attribute ascending order.

◆ QoS Object 72 (Class 0x48)

■ Services Supported

Service Code No. (hex)	Service Name
0E	Get Attribute Single
10	Set Attribute Single

■ Attributes Supported

Instance ID	Attribute	Name	Description	Get	Set	Size	Range	Default
0	1	Object Software Revision	Revision number of the QoS Object	○	-	Word	-	1
1	4	DSCP Urgent	DSCP value for CIP transport class 0/1 Urgent priority messages	○	○	Byte	0 - 63	55
1	5	DSCP Scheduled	DSCP value for CIP transport class 0/1 Scheduled priority messages	○	○	Byte	0 - 63	47
1	6	DSCP High	DSCP value for CIP transport class 0/1 High priority messages	○	○	Byte	0 - 63	43
1	7	DSCP Low	DSCP value for CIP transport class 0/1 Low priority messages	○	○	Byte	0 - 63	31
1	8	DSCP Explicit	DSCP value for CIP explicit messages and all other EtherNet/IP encapsulation messages	○	○	Byte	0 - 63	27

◆ Base Energy Object 78 (Class 0x4E)

Note:

This object is not available in D1000 and R1000. Refer to *Base Energy Object 78 (Class 0x4E) on page 108* for more information about this object compatible with D1000 and R1000.

■ Services Supported

Service Code No. (hex)	Service Name
0E	Get Attribute Single
10	Set Attribute Single

■ Attributes Supported

Instance ID	Attribute	Name	Description	Get	Set	Size	Range	Default
0	1	Base Energy Software Revision	Base Energy Object software revision	○	-	Word	-	2
1	1	Energy/Resource Type	Type of energy managed	○	-	Word	-	Always 1 (Electrical)
1	2	Base Energy Object Capabilities	Energy Capabilities of this device	○	-	Word	-	Always 0 (Measured)
1	3	Energy Accuracy	Specifies the accuracy of power and energy metering results.	○	-	Word	-	Always 1000 (10%)
1	7	Consumed Energy Odometer	Consumed energy read from U4-10 [kWh, Lower 4 Digits] and U4-11 [kWh, Upper 5 Digits] in units of kWh.	○	-	ODOMETER Array of 5 words	0 - 999,999,999,999.999	-
1	8	Generated Energy Odometer	Always returns 0	○	-	ODOMETER Array of 5 words	0 - 999,999,999,999.999	-
1	9	Net Energy Odometer	The difference between Consumed energy and Generated energy in units of kWh.	○	-	SIGNED ODOMETER Array of 5 signed Words	-999,999,999,999.999 - 999,999,999,999.999	-
1	10	Energy Transfer Rate	Output Power read from monitor U1-08 [Output Power] in units of kW. In IEEE 754 REAL format.	○	-	REAL	Depends on capacity	-
1	12	Energy Type Specific Object Path	EPATH to Electrical Energy Object	○	-	STRUCT of UINT Size Padded EPATH	-	Always 02 20 4F 24 01

◆ Electrical Energy Object 79 (Class 0x4F)

Note:

This object is not available in D1000 and R1000. Refer to [Electrical Energy Object 79 \(Class 0x4F\) on page 109](#) for more information about this object compatible with D1000 and R1000.

■ Services Supported

Service Code No. (hex)	Service Name
0E	Get Attribute Single
10	Set Attribute Single

■ Attributes Supported

Instance ID	Attribute	Name	Description	Get	Set	Size	Range	Default
0	1	Electrical Energy Software Revision	Electrical Energy Object software revision	○	-	Word	-	2
1	1	Consumed Energy Odometer	Consumed energy read from U4-10 [kWh, Lower 4 Digits] and U4-11 [kWh, Upper 5 Digits] in units of kWh.	○	-	ODOMETER Array of 5 words	0 - 999,999,999,999.999	-
1	2	Generated Energy Odometer	Always returns 0	○	-	ODOMETER Array of 5 words	0 - 999,999,999,999.999	-
1	3	Net Energy Odometer	The difference between Consumed energy and Generated energy in units of kWh.	○	-	SIGNED ODOMETER Array of 5 signed Words	-999,999,999,999.999 - 999,999,999,999.999	-
1	41	Energy Type Specific Object Path	EPATH to Base Energy Object	○	-	STRUCT of UINT Size Padded EPATH	-	Always 02 20 4E 24 01

◆ TCP/IP Object 245 (Class 0xF5)

■ Services Supported

Service Code No. (hex)	Service Name
01	Get Attribute All
0E	Get Attribute Single
10	Set Attribute Single

■ Attributes Supported

Instance ID	Attribute	Name	Description	Get	Set	Size	Range	Default
0	1	Object Software Revision	Revision number of the TCP/IP Object	○	-	Word	-	3
1	1	Status	Bits 0-3 = Interface Status 0: Interface has not been configured 1: Interface Configuration is valid, obtained from BOOTP, DHCP, or NVRAM 2: Interface Configuration is valid and obtained from hardware settings 3: Reserved Bit 4 = Multicast Pending Bits 5-31 = Reserved	○	-	DWord	-	-
1	2	Configuration Capability	Bit 0 = BOOTP Client Bit 1 = DNS Client Bit 2 = DHCP Client Bit 3 = DHCP-DNS Update Bit 4 = Configuration Settable Bits 5-31 = Reserved	○	-	DWord	-	-
1	3	Configuration Control	Bits 0-3 = Startup Configuration 0: NVRAM 1: BOOTP 2: DHCP 3: Reserved Bit 4 = DNS Enabled (not supported) Bits 5-31 = Reserved	○	○	DWord	-	-
1	4	Physical Link	Struct of: Path Size: First 2 bytes Path: Remaining bytes	○	-	Struct	-	02 00 20 F6 24 01
1	5	Interface Configuration	Struct of: IP Address: Long Subnet Mask: Long Gateway Address: Long Name Server1: Long Name Server2: Long Domain Name: STRING	○	○	Struct	-	-
1	6	Host Name	Host Name	○	○	String	64 Characters	Null
1	10	SelectACD	Activates the use of ACD	○	○	BOOL	0, 1	1
1	11	Last Conflict Detected	AcdActivity	○	○	USINT	0, 1, 2, 3	0
			RemoteMAC	○	○	Array of 6 bytes	00 00 00 00 00 00 FF FF FF FF FF FF	00 00 00 00 00 00
			ArpPdu	○	○	Array of 28 bytes	-	00 00
1	13	Encapsulation Inactivity Timeout	Number of seconds of inactivity before TCP connection is closed.	○	○	UINT	1 s - 3600 s	120 s

Note:

“Get Attributes All” Service shall report in attribute ascending order.

◆ Ethernet Link Object 246 (Class 0xF6)

■ Services Supported

Service Code No. (hex)	Service Name
01	Get Attribute All
0E	Get Attribute Single
10	Set Attribute Single

■ Attributes Supported

Instance ID	Attribute	Name	Description	Get	Set	Size	Range	Default
0	1	Object Software Revision	Revision number of the Ethernet Link Object	○	-	Word	-	3
0	2	Max Instance	Number of Option Instances	○	-	UINT	-	2
0	3	Number of Instances	Number of Option Instances	○	-	UINT	-	2
1	1	Interface Speed	Interface speed currently in use	○	-	UDINT	-	-
1	2	Interface Flags	Bit 0 = Link Status Bit 1 = Duplex (0: half duplex, 1: full duplex) Bits 2-4 = Negotiation Status 0: In progress 1: Auto-negotiate failed 2: Speed found, duplex not found Mode not detected 3: Successful 4: Not attempted Bit 5 = Manual Setting requires restart Bit 6 = Local hardware fault Bits 7-31 = Reserved	○	-	DWord	-	-
1	3	Physical Address (MAC)	MAC address	○	-	Array of 6 Bytes	-	-
1	6	Interface Control	Struct of: Control Bits: Word Bit 0 = Auto-negotiate Bit 1 = Forced Duplex Mode Bits 2-15 = Reserved Forced Int Speed: Word	-	○	Struct	-	-
1	4	Interface Counters (Port 1)	In Octets	○	-	UDINT	0 - 4294967295	0
			In Ucast Packets	○	-	UDINT	0 - 4294967295	0
			In NUcast Packets	○	-	UDINT	0 - 4294967295	0
			In Discards	○	-	UDINT	0 - 4294967295	0
			In Errors	○	-	UDINT	0 - 4294967295	0
			In Unknown Protos	○	-	UDINT	0 - 4294967295	0
			Out Octets	○	-	UDINT	0 - 4294967295	0
			Out Ucast Packets	○	-	UDINT	0 - 4294967295	0
			Out NUcast Packets	○	-	UDINT	0 - 4294967295	0
			Out Discards	○	-	UDINT	0 - 4294967295	0
Out Errors	○	-	UDINT	0 - 4294967295	0			
1	5	Media Counters (Port 1)	Alignment Errors	○	-	UDINT	0 - 4294967295	0
			FCS Errors	○	-	UDINT	0 - 4294967295	0
			Single Collisions	○	-	UDINT	0 - 4294967295	0
			Multiple Collisions	○	-	UDINT	0 - 4294967295	0
			SQE Test Errors	○	-	UDINT	0 - 4294967295	0
			Deferred Trans-missions	○	-	UDINT	0 - 4294967295	0
			Late Collisions	○	-	UDINT	0 - 4294967295	0

Instance ID	Attribute	Name	Description	Get	Set	Size	Range	Default
			Excessive Collisions	o	-	UDINT	0 - 4294967295	0
			MAC Transmit Errors	o	-	UDINT	0 - 4294967295	0
			Carrier Sense Errors	o	-	UDINT	0 - 4294967295	0
			Frame Too Large	o	-	UDINT	0 - 4294967295	0
			MAC Receive Errors	o	-	UDINT	0 - 4294967295	0
1	10	Interface Label (Port 1)	Human readable identification	o	-	STRING	-	Port 1
1	11	Interface Capability (Port 1)	Capability bits	o	-	DWORD	-	000F (Hex.)
			Array of Struct of Speed/Duplex Options	o	-	Array of Struct of UINT	-	-
			Interface Speed			USINT		
			Interface Duplex Mode					
2	4	Interface Counters (Port 2)	In Octets	o	-	UDINT	0 - 4294967295	0
			In Ucast Packets	o	-	UDINT	0 - 4294967295	0
			In NUcast Packets	o	-	UDINT	0 - 4294967295	0
			In Discards	o	-	UDINT	0 - 4294967295	0
			In Errors	o	-	UDINT	0 - 4294967295	0
			In Unknown Protos	o	-	UDINT	0 - 4294967295	0
			Out Octets	o	-	UDINT	0 - 4294967295	0
			Out Ucast Packets	o	-	UDINT	0 - 4294967295	0
			Out NUcast Packets	o	-	UDINT	0 - 4294967295	0
			Out Discards	o	-	UDINT	0 - 4294967295	0
			Out Errors	o	-	UDINT	0 - 4294967295	0
2	5	Media Counters (Port 2)	Alignment Errors	o	-	UDINT	0 - 4294967295	0
			FCS Errors	o	-	UDINT	0 - 4294967295	0
			Single Collisions	o	-	UDINT	0 - 4294967295	0
			Multiple Collisions	o	-	UDINT	0 - 4294967295	0
			SQE Test Errors	o	-	UDINT	0 - 4294967295	0
			Deferred Trans-missions	o	-	UDINT	0 - 4294967295	0
			Late Collisions	o	-	UDINT	0 - 4294967295	0
			Excessive Collisions	o	-	UDINT	0 - 4294967295	0
			MAC Transmit Errors	o	-	UDINT	0 - 4294967295	0
			Carrier Sense Errors	o	-	UDINT	0 - 4294967295	0
			Frame Too Large	o	-	UDINT	0 - 4294967295	0
			MAC Receive Errors	o	-	UDINT	0 - 4294967295	0
2	10	Interface Label (Port 2)	Human readable identification	o	-	STRING	-	Port 1
2	11	Interface Capability (Port 2)	Capability bits	o	-	DWORD	-	000F (Hex.)
			Array of Struct of Speed/Duplex Options	o	-	Array of Struct of UINT	-	-
			Interface Speed			USINT		
			Interface Duplex Mode					

Note:

“Get Attributes All” Service shall report in attribute ascending order.

13 General Class Objects (Converter)

◆ Motor Data Object - 40 (Class 0x28)

■ Services Supported

Service Code No. (Hex.)	Service Name
0E	Get Attribute Single
10	Set Attribute Single

■ Attributes Supported

Instance ID	Attribute	Name	Description	Get	Set	Size	Range	Default
0	1	Object Software Revision	Motor Data Object software revision.	○	-	Word	-	1
1	3	Motor Type	Type of motor used. 0: Other than standard motor	○	-	Byte	-	0

◆ Control Supervisor Object 41 (Class 0x29)

■ Services Supported

Service Code No. (Hex.)	Service Name
0E	Get Attribute Single
10	Set Attribute Single
05	Reset

■ Attributes Supported

Instance ID	Attribute	Name	Description	Get	Set	Size	Range	Default
0	1	Object Software Revision	Motor Data Object software revision.	○	-	Word	-	1
1	3	Run 1 (Command)	D1000: 0: Stop 1: Run R1000: 0: Stop 1: Auto Run	○	○	Byte	0, 1	0
1	4	Run 2 (Command)	D1000: - R1000: 0: Stop 1: Force Run	○	○	Byte	0, 1	0
1	5	NetCtrl (Command)	Run command is from network 0: Depends on b1-02 1: Run command is from network	○	○	Byte	0, 1	0
1	6	State	State 2: Not Ready 3: Ready (Stopped) 4: Enabled (Run command present) 5: Deceleration to Stop 6: Fault Stop 7: Fault	○	-	Byte	-	3
1	7	Running 1	D1000: 0: Stop 1: Running R1000: 0: Stop 1: Auto Run	○	-	Byte	-	0
1	8	Running 2	D1000: - R1000: 0: Stop	○	-	Byte	-	0

Instance ID	Attribute	Name	Description	Get	Set	Size	Range	Default
			1: Force Run					
1	9	Ready	Ready 0: Not Ready 1: Ready	○	-	Byte	-	1
1	10	Faulted	Faulted 0: No Fault 1: Fault	○	-	Byte	-	0
1	11	Alarm	Alarm 0: No Alarm 1: Alarm	○	-	Byte	-	0
1	12	Fault Reset	Fault Reset 0: - 1: Fault Reset	○	○	Byte	0, 1	0
1	13	Fault Code	Current Fault Refer to page 97 for more information.	○	-	Word	-	0000
1	15	NetCtrl (Status)	Run command is from network 0: Run command is not from network 1: Run command is from network	○	-	Byte	-	0
1	16	EtherNet/IP Fault Mode	Normal 2 (Vendor Specific)	○	-	Byte	-	2
1	17	Force Fault	External Fault 0: - 1: External Fault [EF0] Triggered by the rising edge of the signal.	○	○	Byte	0, 1	0
1	18	Force Reset	External Fault status 0: - 1: External Fault [EF0] Triggered by the rising edge of the signal.	○	-	Byte	-	0
1	20	Net Idle Mode	Operation mode selection when communication is in Idle Mode. 0: Stop 1: Ignore 2: Stop if F6-01 is set to fault mode. 3: Forward Run 4: Reverse Run Note: Available in option software versions PRG: 0345 and later.	○	○	-	0 - 4	

◆ AC/DC Drive Object - 42 (Class 0x2A)

■ Services Supported

Service Code No. (Hex.)	Service Name
0E	Get Attribute Single
10	Set Attribute Single

■ Attributes Supported

Instance ID	Attribute	Name	Description	Get	Set	Size	Range	Default
0	1	Object Software Revision	Revision number of AC/DC drive object	○	-	Word	-	1
1	4	NetRef (Command)	Voltage command is from network 0: Voltage command is not from network 1: Voltage command is from network	○	-	Byte	-	0
1	6	Drive Mode	Control Mode 0: Vendor Specific Control Mode	○	○	Byte	0	0
1	7	Voltage Actual	Voltage read from U1-52 [DC Bus DC Bus Voltage].	○	-	Word	-	-

13 General Class Objects (Converter)

Instance ID	Attribute	Name	Description	Get	Set	Size	Range	Default
1	8	Voltage Command	D1000: Sets with <i>d8-01</i> [DC Bus Voltage Reference]. R1000: -	○	○	Word	-	-
1	9	Current Actual	D1000: Current read from <i>U1-53</i> [DC Bus Side Current]. R1000: -	○	-	Word	-	0
1	15	Power Actual [W]	D1000: Output power read from <i>U1-56</i> [DC Bus Side Power]. R1000: -	○	-	Word	-	0
1	17	Output Voltage [V]	Output voltage read from <i>U1-52</i> [DC Bus Voltage Feedback].	○	-	Word	-	0
1	22	Voltage Scale (-15 - +15)	Scale of Units for Voltage Related Data Sets or verifies <i>F7-21</i> [EtherNet/IP Voltage Scale Factor].	○	○	Byte	-15 - +15	0
1	23	Current Scale (-15 - +15)	Scale of Units for Current Related Data Sets or verifies <i>F7-18</i> [EtherNet/IP Current Scale Factor].	○	○	Byte	-15 - +15	0
1	24	Torque Scale (-15 - +15)	Scale of Units for Torque Related Data Sets or verifies <i>F7-19</i> [EtherNet/IP Torques Scale Factor].	○	○	Byte	-15 - +15	0
1	26	Power Scale (-15 - +15)	Scale of Units for Power Related Data Sets or verifies <i>F7-20</i> [EtherNet/IP Power Scaling Factor].	○	○	Byte	-15 - +15	0
1	27	Voltage Scale (-15 - +15)	Scale of Units for Voltage Related Data Sets or verifies <i>F7-21</i> [EtherNet/IP Voltage Scale Factor].	○	○	Byte	-15 - +15	0
1	28	Time Scale (-15 - +15)	Scale of Units for Time Related Data Sets or verifies <i>F7-22</i> [EtherNet/IP Time Scaling].	○	○	Byte	-15 - +15	0
1	29	NetRef (Status)	Voltage command is from network 0: Voltage command is not from network 1: Voltage command is from network	○	-	Byte	-	0

◆ Base Energy Object 78 (Class 0x4E)

■ Services Supported

Service Code No. (Hex.)	Service Name
0E	Get Attribute Single
10	Set Attribute Single

■ Attributes Supported

Instance ID	Attribute	Name	Description	Get	Set	Size	Range	Default
0	1	Base Energy Software Revision	Base Energy Object software revision	○	-	Word	-	2
1	1	Energy/Resource Type	Type of energy managed	○	-	Word	-	Always 1 (Electrical)
1	2	Base Energy Object Capabilities	Energy Capabilities of this device	○	-	Word	-	Always 0 (Measured)
1	3	Energy Accuracy	Specifies the accuracy of power and energy metering results.	○	-	Word	-	Always 1000 (0.01%)
1	7	Consumed Energy Odometer	D1000: Consumed energy read from <i>U9-01</i> [Electric Power (GWh)] to <i>U9-03</i> [Electric Power (kWh)]. R1000: Always 0	○	-	ODOMETER Array of 5 words	0 - 999,999,999,999 .999	-
1	8	Generated Energy Odometer	Regenerative power read from <i>U9-04</i> [Regenerative Power (GWh)] to <i>U9-06</i> [Regenerative Power (kWh)].	○	-	ODOMETER Array of 5 words	0 - 999,999,999,999 .999	-

Instance ID	Attribute	Name	Description	Get	Set	Size	Range	Default
1	9	Net Energy Odometer	The difference between Consumed energy and Generated energy in units of kWh.	○	-	SIGNED ODOMETER Array of 5 signed Words	-999,999,999,999,999 - 999,999,999,999,999	-
1	10	Energy Transfer Rate	D1000: DC Bus power read from U1-56 [DC Bus Side Power] in units of 1kW. In IEEE 754 REAL format.	○	-	REAL	Depends on capacity	-
1	12	Energy Type Specific Object Path	EPATH to Electrical Energy Object	○	-	STRUCT of UINT Size Padded EPATH	-	Always 02 20 4F 24 01

◆ Electrical Energy Object 79 (Class 0x4F)

■ Services Supported

Service Code No. (Hex.)	Service Name
0E	Get Attribute Single
10	Set Attribute Single

■ Attributes Supported

Instance ID	Attribute	Name	Description	Get	Set	Size	Range	Default
0	1	Electrical Energy Software Revision	Electrical Energy Object software revision	○	-	Word	-	2
1	1	Consumed Energy Odometer	D1000: Consumed energy read from U9-01 [Electric Power (GWh)] to U9-03 [Electric Power (kWh)]. R1000: Always 0	○	-	ODOMETER Array of 5 words	0 - 999,999,999,999,999	-
1	2	Generated Energy Odometer	Regenerative power read from U9-04 [Regenerative Power (GWh)] to U9-06 [Regenerative Power (kWh)].	○	-	ODOMETER Array of 5 words	0 - 999,999,999,999,999	-
1	3	Net Energy Odometer	The difference between Consumed energy and Generated energy in units of kWh.	○	-	ODOMETER Array of 5 signed Words	-999,999,999,999,999 - 999,999,999,999,999	-
1	9	Line Frequency	Power supply frequency read from U1-58 [Power Supply Frequency]. In IEEE 754 REAL format.	○	-	REAL	-	0
1	13	Average Current	Power supply current read from U1-55 [Power Supply Current]. In IEEE 754 REAL format.	○	-	REAL	-	0
1	18	Average L-N Voltage	Power supply voltage read from U1-54 [Power Supply Voltage]. In IEEE 754 REAL format.	○	-	REAL	-	0
1	39	Three Phase True Power Factor	D1000: Power factor read from U1-60 [Power Factor]. In IEEE 754 REAL format.	○	-	REAL	-	0
1	41	Energy Type Specific Object Path	EPATH to Base Energy Object	○	-	STRUCT of UINT Size Padded EPATH	-	Always 02 20 4E 24 01

14 Vendor-Specific (Yaskawa) Class Objects

◆ Yaskawa Drive Parameters Object - 100 (Class 0x64)

■ Services Supported

Service Code No. (Hex.)	Service Name
0E	Get Attribute Single
10	Set Attribute Single

Yaskawa Drive Parameters object is related to the parameters or monitor of Yaskawa drives. Not compatible with EtherNet/IP compatible drives from a different company. With this Class object any drive parameter or monitor

with a MEMOBUS/Modbus address greater than 0x00FF can be accessed. The mapping of Class Object instance/attribute to MEMOBUS/Modbus address is as follows.

Given a typical MEMOBUS/Modbus Address of 0xXXYY

The EtherNet/IP Instance value is equal to XX

The EtherNet/IP Attribute value is equal to YY

As an example, to access parameter *b5-12* [MEMOBUS/Modbus Address = 0x01B0]

Class Object is 100 (0x64) (Always for this Class Object)

Instance = 0x01

Attribute = 0xB0

■ Storing Changed Parameters

Writing a zero to 0x0900 (Enter) stores changed parameters to the non-volatile memory of the drive. Writing a 0 to 0x0910 (Accept) allows the drive to use the changed parameters. Reading Enter Command 0x0900 or Accept Command 0x910 will always return a value of 0x0001.

Performing a RAM-ENTER to Store Register Data

Parameter *H5-11* is used to decide whether a RAM-ENTER will be done on the writes to registers in the drive. If *H5-11* = 1 [default], the option will issue the RAM-ENTER with the parameter writes. If *H5-11* = 0, no RAM-ENTER is issued and an ENTER command must be explicitly sent by the user for the parameter to be activated after a write.

Explicit writes to RAM-ENTER (0x910) and ROM-ENTER (0x900) are handled as special cases. If a user writes a 0 to RAM-ENTER or ROM-ENTER, the command will be executed in the drive. If a user writes a 1 to those registers, the command will not be executed but returns a success to the explicit write on the network. Writing a value other than 0 or 1 will result in an error response of Invalid Attribute Value on the network.

Note:

Performing the RAM-ENTER increases the processing time of the writes and increases the response time to explicit writes.

■ Attributes Supported

Instance ID	Attribute	Name	Description	Get	Set	Size	Range	Default
0	1	Object Software Revision	Yaskawa Drive Parameters object software revision	○	-	Word	-	1
1	00	MEMOBUS/Modbus Register 0x0100	Language selection	○	○	Word	0 - 12	1
1	01	MEMOBUS/Modbus Register 0x0101	Parameter access level	○	○	Word	0 - 2	2
1	YY	MEMOBUS/Modbus Registers 0x0100 - 0x01FF	MEMOBUS/Modbus Registers 0x0100 - 0x01FF	○	○	Word	-	-
2	YY	MEMOBUS/Modbus Registers 0x0200 - 0x02FF	MEMOBUS/Modbus Registers 0x0200 - 0x02FF	○	○	Word	-	-
..	-	○	Word	-	-
255	YY	MEMOBUS/Modbus Registers 0xFF00 - 0xFFFF	MEMOBUS/Modbus Registers 0xFF00 - 0xFFFF	○	○	Word	-	-

Note:

1. Refer to [Explicit Message Communications Errors on page 119](#) for error codes.
2. Refer to the MEMOBUS/Modbus Data Table in the MEMOBUS/Modbus Communications chapter of the drive manual for a list of monitor data using the MEMOBUS/Modbus message area.

◆ Yaskawa Monitor/Control Object - 125 (Class 0x7D)

■ Services Supported

Service Code No. (Hex.)	Service Name
0E	Get Attribute Single
10	Set Attribute Single

Yaskawa Monitor/Control object is related to the parameters or monitors of Yaskawa drives. Not compatible with the EtherNet/IP compatible drives from another company. With this Class object any parameter or monitor with a MEMOBUS/Modbus address less than 0x0100 can be accessed. In this class, the most significant byte of MEMOBUS/Modbus address is always zero and the Instance ID remains at 1. Other than that, it is the same as Yaskawa Drive Parameters object 100 (Class0x64).

Given a typical MEMOBUS/Modbus Address of 0x00YY

The EtherNet/IP Instance value is equal to 0x01

The EtherNet/IP Attribute value is equal to YY

As an example, to access Drive Status (MEMOBUS/Modbus Address = 0x002C)

Class Object is 125 (0x7D) (Always for this Class Object)

Instance = 0x01

Attribute = 0x2C

■ Attributes Supported

Instance ID	Attribute	Name	Description	Get	Set	Size	Range	Default
0	1	Object Software Revision	Shows Yaskawa Monitor/Control Object Software Revision.	○	-	Word	-	1
1	1	0x0001	Drive Command Bits	○	○	Word	-	0
1	2	0x0002	Frequency Instruction	○	○	Word	-	4
..	○	○	Word	-	-
1	255	0x00FF	Reserved	○	○	Word	-	-

Note:

1. Refer to *Explicit Message Communications Errors on page 119* for error codes.
2. Refer to the MEMOBUS/Modbus Data Table in the MEMOBUS/Modbus Communications chapter of the drive manual for a list of monitor data using the MEMOBUS/Modbus message area.

15 Web Interface

The option contains a series of web pages that let you use a standard web browser to view status and diagnostic information.

The web page is accessed through a self-contained web server at port 80. Type the IP address of the option into a web browser to access the home page. Example: "http://192.168.1.20" The IP address of the option can be read using monitors *U6-80 to U6-83 [Option IP Address 1 to Option IP Address 4]* on the keypad if it is unknown. Refer to [Table 6.1](#) for more information.

- Home Page
- EtherNet/IP Page
- Network Page
- Ring Page
- Chart Page
- Email Alerts Page
- Parameter Access Page
- Settings Page

◆ Home Page

The Home page shows the status of the drive and the I/O. It also shows identifying information about the drive and the option.



Figure 15.1 Home Page View

◆ EtherNet/IP Page

The EtherNet/IP page shows basic information about the protocol. Up to two connections can be active at a time. The connections will show which assemblies are used and what type of connection it is.

At the bottom of the page, the EDS file for attached drive can be downloaded. This can be used in the PLC software.

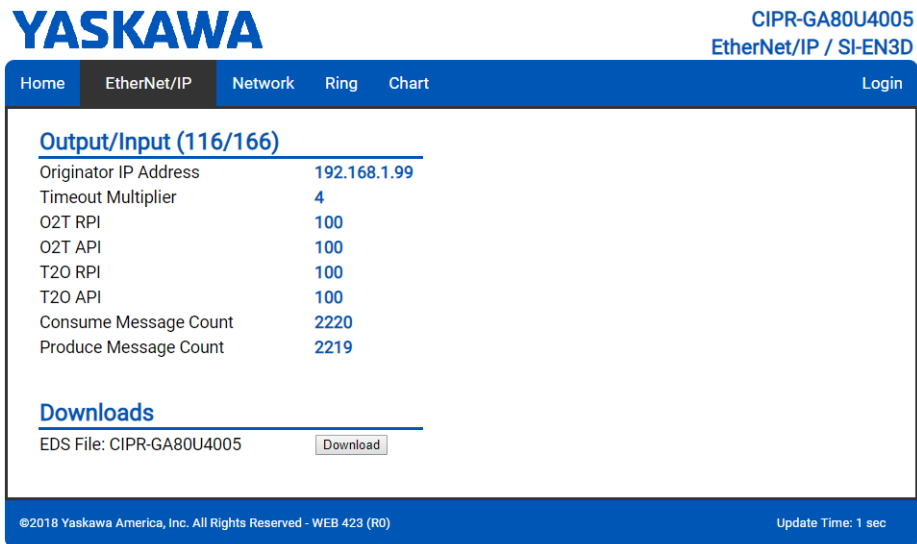

Figure 15.2 EtherNet/IP Page View

Network Monitor	Explanation
Originator IP Address	The IP address of the master PLC on the network
Timeout Multiplier	If a packet is not received in the time specified by the RPI times the Connection Timeout Multiplier, the connection is broken.
O2T RPI	Requested Packet Interval between the originator (PLC) and the target (drive)

Network Monitor	Explanation
O2T API	Actual Packet Interval between the originator (PLC) and the target (drive)
T2O RPI	Requested Packet Interval between the target (drive) and the originator (PLC)
T2O API	Actual Packet Interval between the target (drive) and the originator (PLC)
Consume Message Count	Cumulative number of messages received from the PLC
Produce Message Count	Cumulative number of messages sent to the PLC

Note:

Cumulative counters are reset when the power supply is cycled.

◆ Network Page

The embedded network monitor page shows the status of the option network traffic and open I/O connections.



CIPR-GA80U4005
 EtherNet/IP / SI-EN3D

Home EtherNet/IP Network Ring Chart Login			
Identity		Packet Counters	
IP Address	192.168.1.20	Ok	6790 588066
Subnet Mask	255.255.255.0	Errors	1 1
Gateway Address	192.168.1.1	Dropped	0 0
MAC Address	00:20:B5:88:79:00		
Address Mode	Static	Interface Counters	
		Status	Port 1 Port 2
Link Status	Active Active	In Octets	24051718 25085639
Speed	100 Mbps 100 Mbps	In Ucast Packets	1 7491
Duplex	Full Full	In NUCast Packets	377610 379198
Auto-Negotiation	Successful Successful	Out Octets	24354211 24929241
		Out Ucast Packets	13 2966
		Out NUCast Packets	378991 377252
Misc		Media Counters	
Retry	0	Alignment Errors	0 0
Collisions	0	FCS Errors	0 0
Current Connections	1	Single Collisions	0 0
		Multiple Collisions	0 0
		Late Collisions	0 0
		Deferred Collisions	0 0
		Excessive Collisions	0 0
		Frame Too Large	0 0

©2018 Yaskawa America, Inc. All Rights Reserved - WEB 423 (R0)
Update Time: 1 sec

Figure 15.3 Network Page View

Network Monitor	Explanation
Msg Tx OK	Cumulative number of messages transmitted successfully from the option.
Msg Rx OK	Cumulative number of messages received successfully to the option.
Msg Tx Dropped	Cumulative number of messages dropped due to output network buffer being full and unable to hold the new message.
Msg Rx Dropped	Cumulative number of messages dropped due to input network buffer being full and unable to hold the new message.
Collisions	Cumulative number of collisions (half duplex only) reported by the MAC/PHY (Media Access Control/Physical Connection).
Msg Tx Errors	Cumulative number of transmit underruns and transmit stops reported by the MAC/PHY.
Msg Rx Errors	Cumulative number of receive overruns, receive stops, and receive error frames reported by the MAC/PHY.
Tx Retry	Cumulative number of transmits in which the 1st attempt was delayed due to busy medium reported by the MAC/PHY.
Current Connections	Current number of open connections.
IP Address	IP Address of the option.
Subnet Mask	Subnet Mask of the option.
Gateway Address	The Gateway IP Address that the option will use.
MAC Address	MAC Address of the option.
Address Mode	Either static IP address or DHCP.

Network Monitor	Explanation
Link Status	Active if the cable is plugged in, or inactive if no cable.
Speed	Connection speed, either 10 Mbps or 100 Mbps.
Duplex	Display either Full or Half.
Auto-Negotiation	If auto-negotiation is enabled, this will show the status of the negotiation.
In Octets	Cumulative number of incoming octets.
In Ucast Packets	Cumulative number of unicast packets received.
In NUcast Packets	Cumulative number of non-unicast packets received.
Out Octets	Cumulative number of outgoing octets.
Out Ucast Packets	Cumulative number of unicast packets sent.
Out NUcast Packets	Cumulative number of unicast packets sent.
Alignment Errors	Cumulative number of errors for uneven packets lengths.
FCS Errors	Cumulative number of frame check sequence errors.
Single Collisions	Cumulative number of single collisions.
Multiple Collisions	Cumulative number of multiple collisions.
Late Collisions	Cumulative number of late collisions.
Deferred Collisions	Cumulative number of deferred collisions.
Excessive Collisions	Cumulative number of excessive collisions.
Frame Too Large	Cumulative number of frames that exceed the maximum frame size.

Note:

Cumulative counters are reset when the power supply is cycled.

◆ **Ring Page**

The Ring page shows the status of the DLR or RSTP network. DLR or RSTP can be enabled from this page. To change the Ring Protocol, you will need to be logged into the page first.

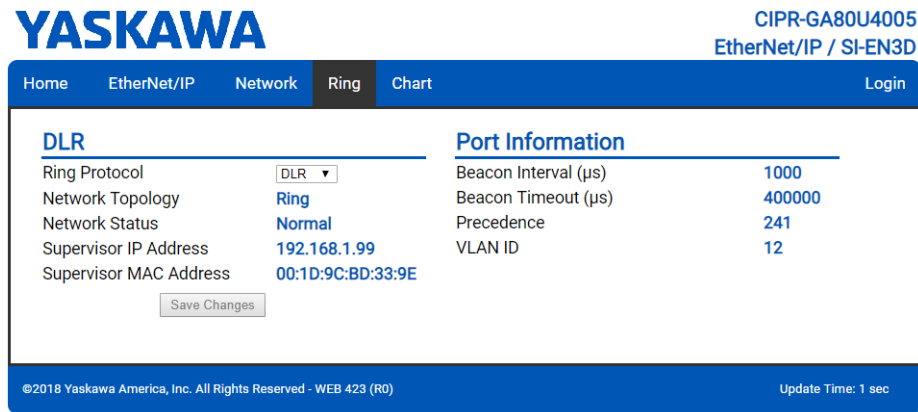

Figure 15.4 Ring Page View

Network Monitor	Explanation
Ring Protocol	The ring protocol can be set by selecting either DLR or RSTP from the drop-down box. After the select has been changed, the user will need to Login and click the [Save Changes] button to commit the changes to the option. After two seconds, the web page will automatically refresh, showing the values of the new ring protocol.
Network Topology	This will show the active network topology. It will either display Linear, if there is not a DLR ring established, or will display Ring if there is a DLR ring established.
Network Status	The network status will display the health of the network. If everything is operational, the status will be Normal. If there is a fault or problem, the status will be Ring Fault.
Supervisor IP Address	Displays the IP address of the supervisor, if it is present on the network.
Supervisor MAC Address	Displays the MAC address of the supervisor, if it is present on the network.
Beacon Interval	Displays the beacon interval set by the supervisor in microseconds.
Beacon Timeout	Displays the beacon timeout set by the supervisor in microseconds.

Network Monitor	Explanation
Precedence	Displays the precedence of the active supervisor.
VLAN ID	Displays the VLAN ID that the active supervisor is using.

◆ Chart Page

The Chart page can be used to monitor one signal from a predefined list.

- Frequency Instruction
- Output Frequency
- Output Current
- Motor Speed
- Torque Reference
- DC Bus Voltage
- Terminal Analog Input 1
- Terminal Analog Input 2
- Terminal Analog Input 3

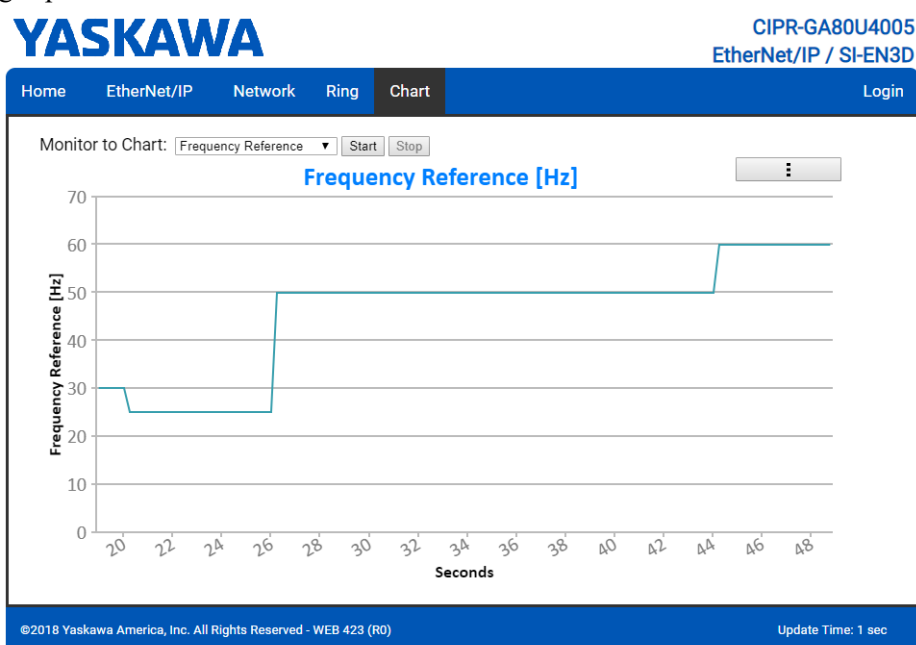

Figure 15.5 Chart Page View

◆ Email Alerts Page

The Email Alerts page allows the user to configure four Email Fault/Alarm conditions. When the condition is true, one email will be sent to the provided email address. Another email will not be sent until the condition becomes false and then true again.

A 30-second timer prevents emails from being sent when conditions reoccur immediately after being removed. The timer helps limit the amount of emails sent regarding the same intermittent condition and helps to reduce network traffic by reducing emails about reoccurring errors.

Clicking [Save Email Settings] will save the entered information into the option.

The screenshot shows the 'Email Alerts' page in the YASKAWA web interface. It features four sections for configuring conditional email alerts, labeled 'Conditional Email 1' through 'Conditional Email 4'. Each section includes an 'Enable' checkbox, a 'Condition' dropdown menu with options like 'Frequency Reference', 'C', and 'D', an 'Address' field (e.g., 'ToAddress1@ToDomain1'), a 'Subject' field (e.g., 'Subject1'), and a 'Message' text area. A 'Save Email Settings' button is located at the bottom right of the page. The page header includes the YASKAWA logo, the model number 'CIPR-GA80U4005', and the interface type 'EtherNet/IP / SI-EN3D'. The navigation menu includes 'Home', 'EtherNet/IP', 'Network', 'Ring', 'Chart', 'Email Alerts', 'Parameter Access', 'Settings', and 'Logout'.

Figure 15.6 Email Alerts Page View

Procedure: Conditional Email Set-up

1. Click the [Enable] check box to enable the alert.
2. Define the condition that will trigger the email by selecting a monitor parameter, a comparator, and a value. Set the conditions to send alerts from the [Condition] drop-down selection. If choosing only one condition and no OR or AND are needed, set the [OR/AND] drop-down selection to [—].
3. Enter the email address where the alert will be sent.
4. Enter the message that will appear in the email contents.
5. Enter the email subject.

◆ Parameter Access Page

The Parameter Access page allows the user to read and write parameters from the drive. Write access is restricted until a valid password is entered.

The screenshot shows the 'Parameter Access' page in the YASKAWA web interface. The page title is 'Parameter Access'. It contains several input fields and buttons: 'Modbus Register Address (hex)' with a 'Read' button, 'Decimal Value' with a 'Set' button, 'Hex Value' with a 'Set' button, 'Save All Writes to EEPROM (ROM Enter)' with a 'Send ROM Enter' button, and a 'Status' field displaying 'Ready'. The page header includes the YASKAWA logo, the model number 'CIPR-GA80U4005', and the interface type 'EtherNet/IP / SI-EN3D'. The navigation menu includes 'Home', 'EtherNet/IP', 'Network', 'Ring', 'Chart', 'Email Alerts', 'Parameter Access', 'Settings', and 'Logout'.

Figure 15.7 Parameter Access Page View

The MEMOBUS/Modbus address for the drive parameter being accessed must be entered in hexadecimal.

Clicking [Read] will load and display the current value of the given MEMOBUS/Modbus Address.

Clicking [Set] will save the given value to the given MEMOBUS/Modbus address.

After a [Read] or [Set] command is given, Status will display [Waiting] while the action is being carried out, then [Read Successful] or [Write Successful] is displayed when finished.

◆ Settings Page

The Settings page sets web page behavior parameters. Access is restricted unless a valid password is entered.

Figure 15.8 Settings Page View

■ Security Login

Click [Login] and enter a valid password. The button text changes to [Logout].

Note:

The default security password is “yaskawa”.

This password can be changed in the [Webpage Password] section of the page.

Entering a valid password allows access to the settings in the Settings page, Email Alerts page, and the Parameter Access page.

■ Webpage Password

To change the password, enter the new password in the [New Password] and [Confirm Password] text boxes. Click [Save password].

■ Webpage Settings

The values displayed in the various tabs are refreshed at the rate defined in the [Data Update Time] select box. The Data Update Time can be set to 250 ms, 500 ms, 1 second, 2 seconds, or 5 seconds.

■ Email Settings

The [Email Server Address] text box must contain the IP address of the email server. The subnet address is configured in drive parameters *F7-05* through *F7-08*. The configured email alerts will use the server at this address when sending emails.

Enter the email server port in the [Email Server Port] text box.

The value in the [From Email Address] text box identifies the origin of the email alerts to the recipient.

Click [Save Email Settings] to save the email settings to the option.

16 Troubleshooting

◆ Drive-Side Error Codes

Drive-side error codes appear on the drive keypad. *Faults on page 118* lists causes of the errors and possible corrective actions. Refer to the drive Technical Manual for additional error codes that may appear on the drive keypad.

■ Faults

Both *bUS* [Option Communication Error] and *EF0* [Option Card External Fault] can appear as a fault. When a fault occurs, the keypad ALM LED stays lit. When an alarm occurs, the ALM LED flashes.

If communication stops while the drive is running, use these questions as a guide to help remove the fault:

- Is the communication line properly connected to the option? Is it loose?
- Is the option properly installed?
- Is the PLC program working? Is the controller/PLC CPU stopped?
- Did a momentary power loss interrupt communications?

Code	Name	Causes	Possible Solutions
bUS	Option Communication Error	The drive did not receive a signal from the controller.	<ul style="list-style-type: none"> • Check for wiring errors. • Correct the wiring.
		The communications cable wiring is incorrect.	
		An existing short circuit or communications disconnection	Check disconnected cables and short circuits and repair as needed
		A data error occurred due to electric interference	<ul style="list-style-type: none"> • Prevent noise in the control circuit, main circuit, and ground wiring. • If you identify a magnetic contactor as a source of noise, install a surge absorber to the contactor coil. • Use only recommended cables or other shielded line. Ground the shield on the controller side or the drive input power side. • Separate all communication wiring from drive power lines. Install an EMC noise filter to the drive power supply input. • Decrease the effects of electrical interference from the controller.
		Option is damaged	If there are no problems with the wiring and the error continues to occur, replace the option.
		Connection Time-out	Check if the CPU of the controller is not stopped.
	Duplicate IP Address found on network	Change to a different IP address. If <i>F7-13 = 0</i> [Address Mode at Startup = Static], change parameters <i>F7-01</i> to <i>F7-04</i> [IP Address 1 to 4].	
EF0	Option Card External Fault	The option received an external fault from the controller.	<ol style="list-style-type: none"> 1. Find the device that caused the external fault and remove the caus. 2. Clear the external fault input from the controller.
		A programming error occurred on the controller side.	Examine the operation of the controller program.
oFA00	Option Not Compatible with Port	The option connected to connector CN5-A is not compatible.	Connect the option to the correct connector. <ul style="list-style-type: none"> • Use connector CN5-A when you connect the option. To use other options, refer to those option manuals.
oFA01	Option Card Fault (CN5-A)	The option connected to option port CN5-A was changed during run.	<ol style="list-style-type: none"> 1. De-energize the drive. 2. Connect the option to the correct option port.
oFA03, oFA04	Option Card Error (CN5-A)	A fault occurred in the option.	<ol style="list-style-type: none"> 1. De-energize the drive. 2. Make sure that the option is correctly connected to the connector. 3. If the problem continues, replace the option.
oFA30 to oFA43	Option Card Connection Error (CN5-A)	A fault occurred in the option.	<ol style="list-style-type: none"> 1. De-energize the drive. 2. Make sure that the option is correctly connected to the connector. 3. If the problem continues, replace the option.
oFb00	Option Not Compatible with Port	The option connected to connector CN5-B is not compatible.	Connect the option to the correct connector. <ul style="list-style-type: none"> • Use connector CN5-A when you connect the option. To use other options, refer to those option manuals.
oFb02	Option Fault	An option of the same type is already installed in option port CN5-A, CN5-B, or CN5-C.	Connect the option to the correct option port.
oFC00	Option Fault (CN5-B)	The option connected to connector CN5-C is not compatible.	Connect the option to the correct connector. <ul style="list-style-type: none"> • Use connector CN5-A when you connect the option. To use other options, refer to those option manuals.
oFC02	Option Fault	An option of the same type is already installed in option port CN5-A, CN5-B, or CN5-C.	Connect the option to the correct option port.

■ Minor Faults and Alarms

Code	Name	Causes	Possible Solutions
CyPo	Cycle Power to Active Parameters	Comm. Option Parameter Not Upgraded	Re-energize the drive to update the communication option parameters.

◆ bUS Fault Tolerance

■ bUS Fault Auto-Restart

Parameter *F6-14* [*bUS Fault Auto Reset Select*] will appear when the option is installed.

Setting *F6-14* = 0 [*Disabled*] or *F6-01* = 3 or greater (*Alarm only*) will not affect standard default drive behavior.

Setting *F6-14* = 1 [*Enabled*] AND *F6-01* ≠ 3 [*Fault*] will cause the following operation:

1. The bUS fault occurs after the *F7-16* [*Timeout Value*] delay and the Run command is removed from the drive.
2. Then the option throws a *bUS* fault to the drive.
3. When the condition is removed, the option commands a fault reset and returns control of the drive to the EtherNet/IP network.

Note:

The option will only read parameter *F6-01* and *F6-14* from the drive during power-up.

■ bUS Fault Delay

Parameter *F7-16* [*Timeout Value*] will appear when the option is installed. The setting value of *F7-16* is the length of time that the option will delay sending the *bUS* fault to the drive. The status LEDs on the option are not affected by the delay time set in *F7-16*; the LEDs will indicate the *bUS* condition immediately.

Note:

The option will only read parameter *F7-16* from the drive during power-up.

◆ Explicit Message Communications Errors

When there is a problem with a request message sent from the master in explicit communications, the drive will return one of the error codes shown in [Table 16.1](#).

Table 16.1 Communications Errors and Solutions

Error Code (Hex.)	Description	Cause	Possible Solutions
08	Service not supported	The service code is incorrect.	Correct the service code.
09	Invalid attribute value	The attribute is incorrect.	Correct the attribute.
0C	Object state conflict	Attempted to change a drive parameter that cannot be changed while the drive is running.	Stop the drive.
0E	Attribute not settable	Attempted to change a read-only attribute.	Correct the service code or attribute setting.
13	Not enough data	The data size is incorrect.	Correct the data size.
14	Attribute not supported	Attempted to execute a service not defined for the attribute.	Correct the service code or attribute setting.
15	Too much data	The data size is incorrect.	Correct the data size.
16	Object does not exist	An unsupported object was specified.	Correct the class or instance setting.
1F	Vendor-specific error	<ul style="list-style-type: none"> • Attempted to change a drive parameter that cannot be changed while the drive is running. • Attempted to change a drive parameter to a value outside the setting range. 	<ul style="list-style-type: none"> • Stop the drive. • Specify a value within the setting range.
20	Invalid parameter	Attempted to change to a data value outside the setting range.	Specify a data value within the setting range.

◆ Option Error Codes

■ Option Fault Monitors *U6-98* and *U6-99*

The option can declare error/warning conditions via drive monitor parameters on the drive keypad as shown in [Table 16.2](#).

Table 16.2 Option Fault Monitor Descriptions

Status	Fault Declared	Status Value (U6-98/U6-99)	Description
No faults	-	0	No faults
Fatal error occurred	<i>EF0</i>	3	Network sent a message to force this node to the fault state.
Network Link Down	<i>bUS</i>	1100	No network link to option.

Status	Fault Declared	Status Value (U6-98/U6-99)	Description
Communications time-out (non-fatal)	<i>bUS</i>	1101	The node timer (Requested Packet Interval) timed out.
Duplicate IP Address	<i>bUS</i>	1102	This node and at least one other node have the same IP Address.
Default MAC Address	-	1103	Factory default MAC Address programmed into the option. Note: Return the option to Yaskawa or your nearest sales representative and request the setting change.

Two drive monitor parameters, *U6-98 [First Fault]* and *U6-99 [Current Fault]* assist the user in network troubleshooting.

- *U6-98* displays the first declared fault since the last power cycle. *U6-98* is only cleared upon drive power-up.
- *U6-99* displays the present option status. *U6-99* is cleared upon a network-issued fault reset and upon power-up.

If another fault occurs while the original fault is still active, parameter *U6-98* retains the original fault value and *U6-99* stores the new fault status value.

◆ Option Compatibility

You can connect a maximum of 3 options at the same time depending on the type of option.

Note:

- You can only connect one option to the GA500 and HV600 drives. Connect the option to the CN5 connector.
- You can connect two options to an FP605 drive. Connect the communication option to the CN5-A connector.
- Compatible communication options are different for different models. Refer to the drive manuals for more information.

Table 16.3 Option Compatibility

Option	Connector	Number of Options Possible
PG-B3 *1, PG-X3 *1	CN5-B, C	2 *2
PG-RT3 *1 *3 *4, PG-F3 *1 *3 *4	CN5-C	1
DO-A3 *5, AO-A3 *5	CN5-A, B, and C	1
SI-C3, SI-N3, SI-P3, SI-S3, SI-T3, SI-ET3, SI-ES3, SI-B3, SI-M3, SI-W3 *4, SI-EM3 *4, SI-EM3D *4, SI-EN3 *4, SI-EN3D *4, SI-EP3, JOHB-SMP3, AI-A3 *5 *6, DI-A3 *5 *6	CN5-A	1

*1 Not available for GA500, HV600, or FP605 drives.

*2 To connect two PG options, use the CN5-C and CN5-B connectors. To connect only one PG option, use the CN5-C connector.

*3 If you use the motor switching function, you cannot use this option.

*4 Not available for 1000-Series drive models with capacities between 450 and 630 kW (650 to 1000 HP).

*5 Not available for GA500 or HV600 drives.

*6 To use AI-A3 and DI-A3 input statuses as monitors, connect the options to CN5-A, CN5-B, or CN5-C.

17 Option Installation

Verify the following installation conditions to make sure that other devices and machinery used with this option and drive also comply with EMC guidelines:

1. Use dedicated shield cable for the option and external device (encoder, I/O device, master), or run the wiring through a metal conduit.

- Keep wiring as short as possible and ground the largest possible surface area of the shield to the metal panel according to Figure 17.1 and Figure 17.2.

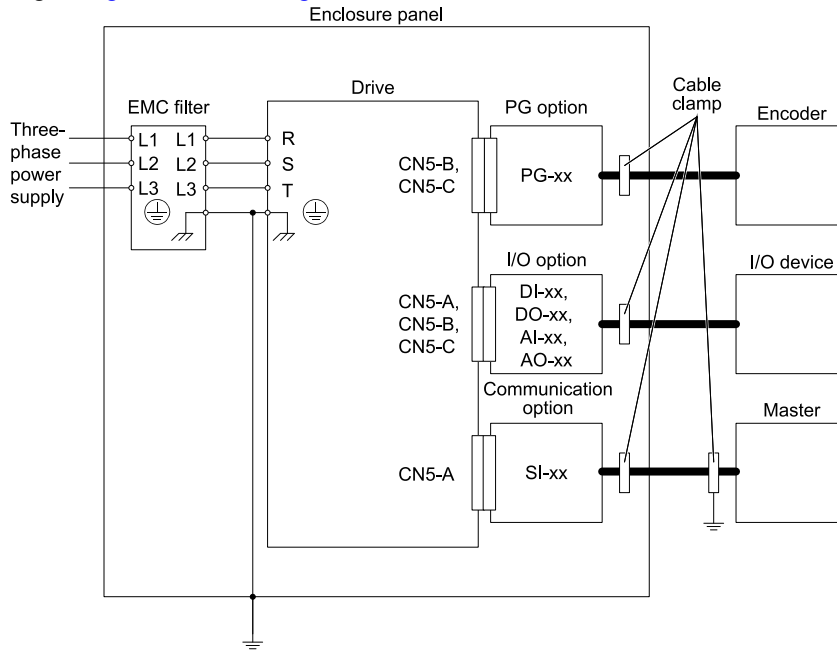

Figure 17.1 Option Installation for CE Compliance: 1000-Series, GA700, GA800

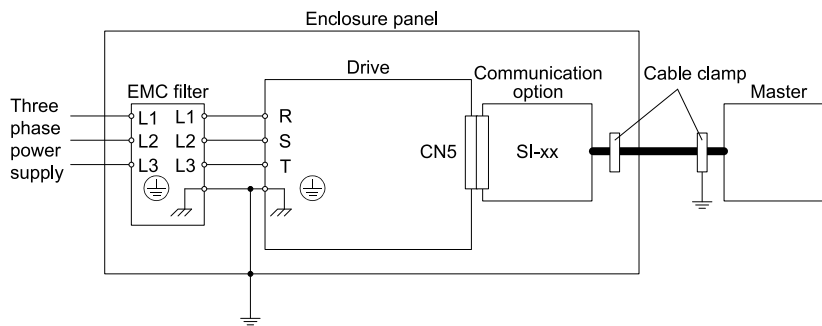

Figure 17.2 Option Installation for CE Compliance: GA500, HV600

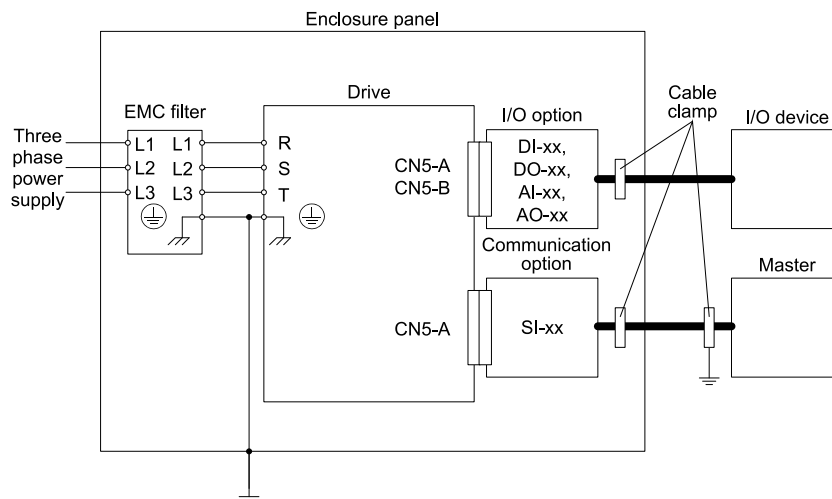
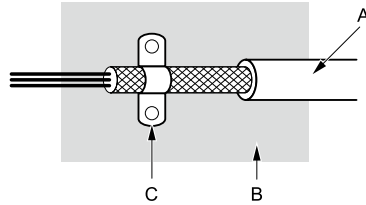

Figure 17.3 Option Installation for CE Compliance: FP605

- Ground the largest possible surface area of the shield to the metal panel. Yaskawa recommends using cable clamps.



A - Braided shield cable
B - Metal panel

C - Cable clamp (conductive)

Figure 17.4 Ground Area

18 Specifications

◆ Specifications

Table 18.1 Option Specifications

Items	Specifications
Model	SI-EN3D
Supported Messages	<ul style="list-style-type: none"> • Explicit: Explicit Class 3, Unconnected • I/O: Class 1, Listen Only, Input Only
I/O Assembly Instance	<ul style="list-style-type: none"> • Input: 12 types (4 - 44 Bytes) • Output: 12 types (4 - 44 Bytes)
EtherNet/IP Specification	Conformance Level CT 15: Passed
EtherNet/IP Profile	AC Drive
Recommended Connector Type	Shielded Cat5e cable
Physical Layer Type	Isolated Physical Layer Ethernet
IP Address Setting	Programmable from drive keypad or network
Communication Speed	Programmable from drive keypad or network: 0/100 Mbps, auto-negotiate
Number of Connections	<ul style="list-style-type: none"> • Explicit: 6 • I/O: 2
Duplex Mode	Half-forced, Auto-negotiate, Full-forced
Address Startup Mode	Static, BOOTP, DHCP
Ambient Temperature	-10 °C - +50 °C (14 °F - 122 °F)
Humidity	Up to 95% RH (no condensation)
Storage Temperature	-20 °C - +60 °C (-4 °F - 140 °F) allowed for short-term transport of the product
Area of Use	Indoors and free from: <ul style="list-style-type: none"> • Oil mist, corrosive gas, flammable gas, and dust • Radioactive materials or flammable materials, including wood • Harmful gas or fluids • Salt • Direct sunlight • Falling foreign objects
Altitude	Up to 1000 m (3280 ft)

19 Disposal

◆ Disposal Instructions

Correctly dispose of the product and packing material as specified by applicable regional, local, and municipal laws and regulations.

◆ WEEE Directive

The wheeled bin symbol on this product, its manual, or its packaging identifies that you must recycle it at the end of its product life.

You must discard the product at an applicable collection point for electrical and electronic equipment (EEE). Do not discard the product with usual waste.

Revision History

Date of Publication	Revision Number	Section	Revised Content
November 2021	1	All	Addition: Information on FP605 Revision: Reviewed and corrected entire documentation
August 2020	-	-	First Edition

YASKAWA AC Drive Option EtherNet/IP Technical Manual

DRIVE CENTER (INVERTER PLANT)

2-13-1, Nishimiyaichi, Yukuhashi, Fukuoka, 824-8511, Japan
Phone: +81-930-25-2548 Fax: +81-930-25-3431
www.yaskawa.co.jp

YASKAWA ELECTRIC CORPORATION

New Pier Takeshiba South Tower, 1-16-1, Kaigan, Minatoku, Tokyo, 105-6891, Japan
Phone: +81-3-5402-4502 Fax: +81-3-5402-4580
www.yaskawa.co.jp

YASKAWA AMERICA, INC.

2121, Norman Drive South, Waukegan, IL 60085, U.S.A.
Phone: +1-800-YASKAWA (927-5292) or +1-847-887-7000 Fax: +1-847-887-7310
www.yaskawa.com

YASKAWA ELÉTRICO DO BRASIL LTDA.

777, Avenida Piraporinha, Diadema, São Paulo, 09950-000, Brasil
Phone: +55-11-3585-1100 Fax: +55-11-3585-1187
www.yaskawa.com.br

YASKAWA EUROPE GmbH

Hauptstraße 185, 65760 Eschborn, Germany
Phone: +49-6196-569-300 Fax: +49-6196-569-398
E-mail: info@yaskawa.eu.com
www.yaskawa.eu.com

YASKAWA ELECTRIC KOREA CORPORATION

35F, Three IFC, 10 Gukjegeumyung-ro, Yeongdeungpo-gu, Seoul, 07326, Korea
Phone: +82-2-784-7844 Fax: +82-2-784-8495
www.yaskawa.co.kr

YASKAWA ASIA PACIFIC PTE. LTD

30A, Kallang Place, #06-01, 339213, Singapore
Phone: +65-6282-3003 Fax: +65-6289-3003
www.yaskawa.com.sg

YASKAWA ELECTRIC (THAILAND) CO., LTD.

59, 1F-5F, Flourish Building, Soi Ratchadapisek 18, Ratchadapisek Road, Huaykwang, Bangkok, 10310, Thailand
Phone: +66-2-017-0099 Fax: +66-2-017-0799
www.yaskawa.co.th

YASKAWA ELECTRIC (CHINA) CO., LTD.

22F, Link Square 1, No.222, Hubin Road, Shanghai, 200021, China
Phone: +86-21-5385-2200 Fax: +86-21-5385-3299
www.yaskawa.com.cn

YASKAWA ELECTRIC (CHINA) CO., LTD. BEIJING OFFICE

Room 1011, Tower W3 Oriental Plaza, No. 1, East Chang An Avenue,
Dong Cheng District, Beijing, 100738, China
Phone: +86-10-8518-4086 Fax: +86-10-8518-4082

YASKAWA ELECTRIC TAIWAN CORPORATION

12F, No. 207, Section 3, Beishin Road, Shindian District, New Taipei City 23143, Taiwan
Phone: +886-2-8913-1333 Fax: +886-2-8913-1513 or +886-2-8913-1519
www.yaskawa.com.tw

YASKAWA INDIA PRIVATE LIMITED

#17/A, Electronics City, Hosur Road, Bengaluru, 560 100 (Karnataka), India
Phone: +91-80-4244-1900 Fax: +91-80-4244-1901
www.yaskawaindia.in

YASKAWA

YASKAWA ELECTRIC
CORPORATION

In the event that the end user of this product is to be the military and said product is to be employed in any weapons systems or the manufacture thereof, the export will fall under the relevant regulations as stipulated in the Foreign Exchange and Foreign Trade Regulations. Therefore, be sure to follow all procedures and submit all relevant documentation according to any and all rules, regulations and laws that may apply.

Specifications are subject to change without notice for ongoing product modifications and improvements.

© 2020 YASKAWA ELECTRIC CORPORATION

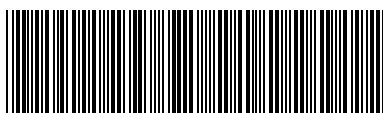

SIEPC730600D

MANUAL NO. SIEP C730600 0DB <1>-0
Published in Japan November 2021
20-2-22
Original Instructions